

16828-GNP



Call Us First!
DO NOT RETURN TO STORE.

For questions on assembly or for general inquiries, you may contact us in the following ways:
Call customer service: **1-877-743-3400**

AVOID THE WAIT!

visit us online at
help.backyardproducts.com

- Submit a help request
- Answers to frequently asked questions
- Live chat with an agent



Did you enjoy building your shed?

JOIN OUR TEAM
AND MAKE UP TO \$1,500/WEEK*

Call a Recruiter Today! 734-365-7000



Flexible schedule



No selling,
just building



Bonus incentives
available

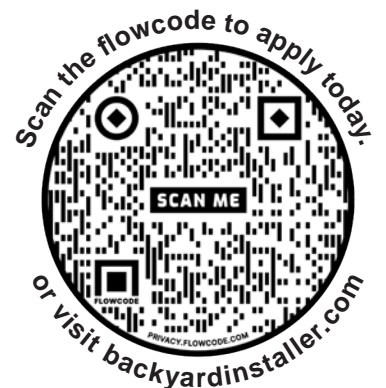

*based on number of completed installations

(This page intentionally left blank.)

Backyard Products, LLC
1000 Ternes Drive
Monroe, MI 48162

GARDEN SHED 6' x 8' (182,9 x 243,8 cm)
ACTUAL FLOOR SIZE IS 72 x 96" (182,9 x 243,8 cm)

KEEP THIS MANUAL FOR FUTURE REFERENCE

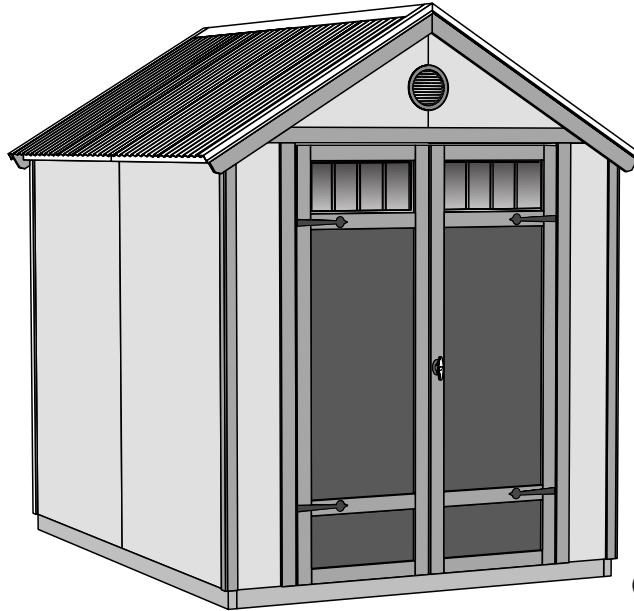

Building
6' x 8'
(182,9 x 243,8 cm)

! IMPORTANT! !

READ INSTRUCTIONS THOROUGHLY PRIOR TO BEGINNING ASSEMBLY.

BEFORE YOU BEGIN

• **BUILDING RESTRICTIONS AND APPROVALS**

Be sure to check with local building department and homeowners association for specific restrictions and/or requirements before building.

• **ENGINEERED DRAWINGS**

Contact our Customer Service Team if engineered drawings are needed to pull local permits.

• **SURFACE PREPARATION**

To ensure proper assembly you must build your shed on a level surface. Recommended methods and materials to level your shed are listed on page 7.

• **CHECK ALL PARTS** Inventory all parts listed on pages 4 - 6.

• **ADDITIONAL MATERIALS**

You will need additional materials to complete your shed. See page 3 for required and optional materials and quantities.











*****CONTACT OUR CUSTOMER SERVICE TEAM
IF ANY PARTS ARE MISSING OR DAMAGED*****







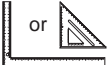

Call: 1-888-827-9056 email: customerservice@backyardproductsllc.com





TOOLS

Required

- Phillips Screwdriver 
- Drill / Driver 
 - 1/8" Drill Bit
 - 1/4" Drill Bit
 - 5/16" Drill Bit
 - 1/2" Drill Bit
 - #2 Phillips Drive Bit
- Hammer 
- Level 
- Pencil 
- Tape Measure 
- Square  or 

- Utility Knife 
 - Shingle Blades 
- Caulk Gun 
- Paint Tools 
- Safety Glasses 
- Hand Saw 
- Ladder 

Optional

- Tool Belt/ Nail Pouch 
- Tin Snips (for drip edge) 
- Chalk Line 
- Nail Gun 
 - gun nails
- Gloves 

Safety! Always use approved safety glasses during assembly.

HELPFUL REMINDER SYMBOLS

Look for these symbols for helpful reminders throughout this manual.



= Assistance Required; two or more people.



= Ensure squareness.



= Important required step or operation.



= Helpful assembly hint.



= Mark part with pencil.



BEGIN = Beginning of steps for assembly or installation.



FINISH = You have finished the assembly or installation.



= Level

ORIENT LUMBER AND TRIM FOR BEST APPEARANCE

Framing lumber is graded for structural strength and not appearance. Exterior trim is graded for one good side.

Always install the material leaving the best edge and best surface visible. Please remember that these blemishes in no way negatively affect the strength or integrity of our product. (See Fig. A, B, C.)

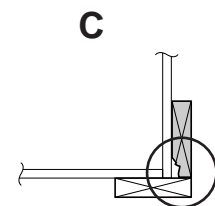
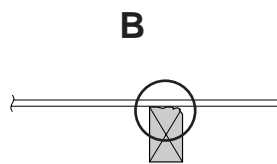
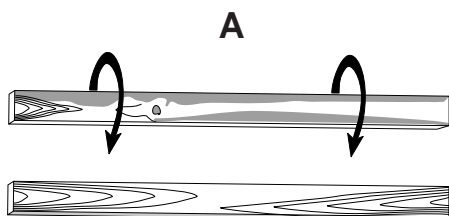

ADDITIONAL MATERIALS

FOUNDATION OR FLOOR MATERIALS

- This shed includes a floor.
- See the FLOOR LEVELING section on page 7 for recommended methods and suggested materials to properly level your floor, as this will vary depending on your specific site.

REINFORCED WOOD FLOOR FRAME (OPTIONAL)

IMPORTANT! This floor has been designed for general use. Depending on your specific use you may want to construct a heavy duty floor frame by adding additional floor joists (shown below as shaded).

Below is a list of additional materials (not included):

- x1** 2 x 4 x 12' (5 x 10 x 365,8 cm) Treated Lumber
Cut to (2) 2 x 4 x 69" (5 x 10 x 175,3 cm)
- x8** ea. 3" (7,6 cm) Hot Dipped Galvanized Nails

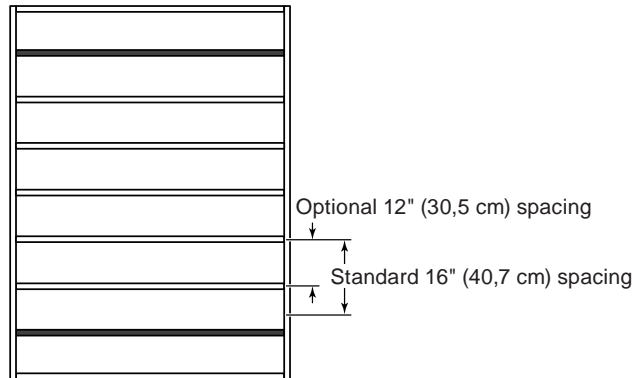

COMPLETING YOUR SHED

You will need these additional materials:

- PAINT FOR SIDING** **2 Gallons**
Use 100% acrylic latex exterior paint. (2) coats recommended.
- PAINT FOR TRIM** **1 Quart**
Use 100% acrylic latex exterior paint.
- CAULK** **1 Tube**
Use acrylic latex exterior caulk that is paintable. 



TO VALIDATE YOUR WARRANTY YOU MUST USE THE FOLLOWING:



- CAULK** **1 Tube** 
For windows use acrylic latex exterior caulk that is paintable.

PARTS IDENTIFICATION AND SIZES

Part identification letters are stamped on some parts.



Check these locations for part stamp.

WOOD SIZE CONVERSION CHART

Nominal Board Size	Actual Size
2 x 4	1-1/2" x 3-1/2" (3,8 x 8,9 cm)
1 x 4	3/4" x 3-1/2" (1,9 x 8,9 cm)
2 x 3	1-1/2" x 2-1/2" (3,8 x 6,3 cm)
1 x 3	3/4" x 2-1/2" (3,8 x 6,3 cm)

PARTS LIST



INVENTORY YOUR PARTS before you begin.

We suggest sorting parts by the category they are listed in.

WALLS

- x1 **GAA** 1 x 3 x 5" (2,5 x 7,6 x 12,7 cm) Gauge Block for 3/4" (1,9 cm) measurement
- x2 **SFA** 2 x 3 x 4-7/8" (5,1 x 7,6 x 12,4 cm)
- x2 **CPA** 2 x 4 x 8-1/2" (5,1 x 10,2 x 21,6 cm)
- x1 **LN** 2 x 3 x 16-1/2" (5,1 x 7,6 x 41,9 cm)
- x2 **XL** 1 x 3 x 64" (2,5 x 7,6 x 162,5 cm)
- x3 **TJA** 2 x 4 x 65" (5,1 x 10,2 x 165,1 cm)
- x19 **UM** 2 x 4 x 68" (5,1 x 10,2 x 172,7 cm)
- x4 **TP** 2 x 4 x 96" (5,1 x 10,2 x 243,8 cm)

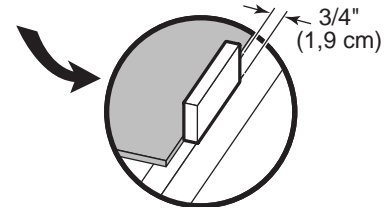

ROOF

- x4 **TP** 2 x 4 x 96" (5,1 x 10,2 x 243,8 cm)
- x4 **JEB** 2 x 3-3/16" x 49-1/2" (5,1 x 8,1 x 125,7 cm)

TRIM

- x2 **IUA** 2 x 3 x 42-5/8" (5,1 x 7,6 x 108,3 cm)
- x2 **DTA** 1 x 3 x 42-5/8" (2,5 x 7,6 x 108,3 cm)
- x2 **WCR** 19/32" x 3-1/2" x 47" (1,5 x 8,9 x 119,4 cm)
- x2 **WCL** 19/32" x 3-1/2" x 47" (1,5 x 8,9 x 119,4 cm)
- x2 **KFC** 19/32" x 2-1/2" x 63-13/16" (1,5 x 6,3 x 162,1 cm)
- x4 3/8" x 1-3/4" x 68-13/16" (1 x 4,4 x 174,8 cm)
- x2 3/8" x 1-3/4" x 70-1/16" (1 x 4,4 x 178 cm)
- x2 3/8" x 1-3/4" x 70-1/16" (1 x 4,4 x 178 cm)

DOORS

- x4 **EGB** 19/32" x 2-1/2" x 18-5/8" (1,5 x 6,3 x 47,3 cm)
- x2 **OO** Door Stiffener 69" (175,3 cm)

FLOOR

- x7 **TREATED** 2 x 4 x 69" (5,1 x 10,2 x 175,3 cm)
- x2 **TREATED** 2 x 4 x 96" (5,1 x 10,2 x 243,8 cm)

Treated lumber is stamped:



SHELVES

- x6 **QOA** 2 x 3 x 6-1/2" (5,1 x 7,6 x 16,5 cm)
- x2 **HJ** 1 x 3 x 72" (2,5 x 7,6 x 182,9 cm)

PANEL PARTS LIST

WALL PANELS & DOORS

Wall panels are 3/8" (1,1 cm) thick.

NOTE: Panel parts are not stamped.

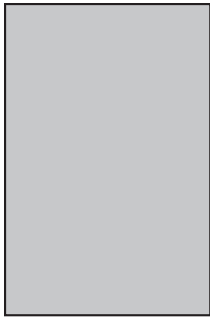

x5
3/8 x 48 x 72"
(1 x 121,9 x 182,9 cm)



x4
3/8 x 11-7/8 x 72"
(1 x 30,2 x 182,9 cm)

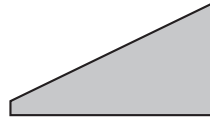

x1
22-1/4 x 35-1/2"
(56,5 x 90,2 cm)

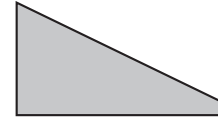

x1
22-1/4 x 35-1/2"
(56,5 x 90,2 cm)

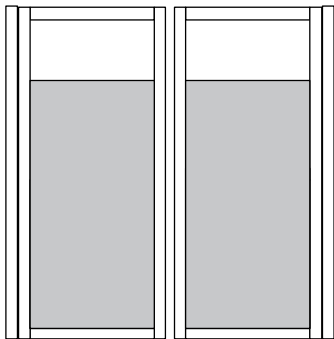

x1
LEFT DOOR

x1
RIGHT DOOR



x1
22-1/4 x 35-1/2"
(56,5 x 90,2 cm)



x1
22-1/4 x 35-1/2"
(56,5 x 90,2 cm)

FLOOR PANELS

Floor panels are 5/8" (1,6 cm) thick.

NOTE: Panel parts are not stamped.



x1
5/8 x 48 x 96"
(1,6 x 121,9 x 243,8 cm)

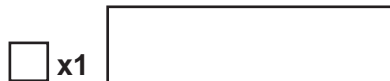

x1
5/8 x 23-7/8 x 96"
(1,6 x 60,6 x 243,8 cm)

SHELF BRACKETS AND PANELS

NOTE: Panel parts are not stamped.

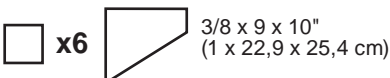

x6
3/8 x 9 x 10"
(1 x 22,9 x 25,4 cm)





x2
7/16 x 7-7/8 x 72" (1,1 x 20 x 243,8 cm)

PARTS LIST continued...

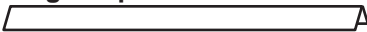
METAL ROOFING

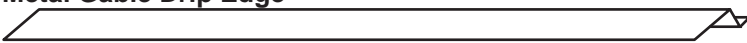
x2 **Ridge Cap**

 4" x 4" x 54" (10,2 x 10,2 x 137,2 cm)

x2 **Metal Gable Drip Edge**

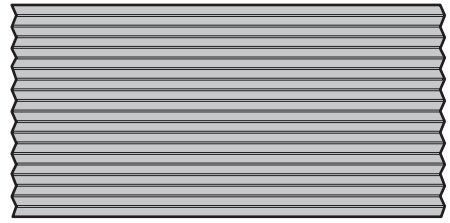
 3" x 95-1/2" (7,6 x 217,2 cm)

x20 **Closure Strip**

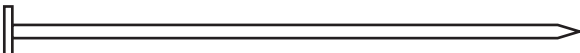
 24" (61 cm)

x10 **Metal Roof Panel**

 25-5/8" x 46-3/4" (65,1 x 118,7 cm)

NAIL BOXES

x2 LBS.  3" (7,6 cm)

x3 LBS.  2" (5,1 cm)

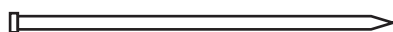
FASTENERS / HARDWARE BAG

x78  2" (5,1 cm)

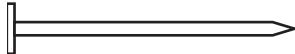
x86  1-1/2" (3,8 cm)

x8  3-1/2" (8,9 cm)

x52  3" (7,6 cm)

x20  2" (5,0 cm)

x8  1-1/2" (3,8 cm)

x42  1-1/4" (3,2 cm)

x10  1" (2,5 cm)

x64  3/4" (1,9 cm)

NOTE:

If you are using a nail gun, nails may be used where screws are shown for quicker assembly. Length of nail must match screw length.

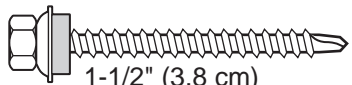

x96  1-1/2" (3,8 cm)

x40  7/8" (2,2 cm)

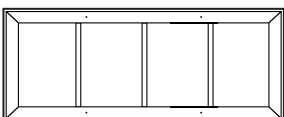

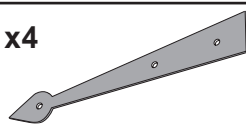
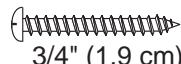
VENT/ DOOR HARDWARE/ WINDOW

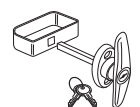
x2 
Transom Window

x4 
 x12  3/4" (1,9 cm)

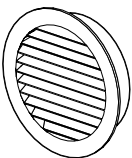
Handle (locking) with Screws

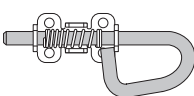
 x2  1-1/4"
 x1

x1 
Gable Vent

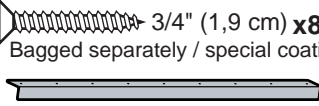
x2 
 x8  3/4" (1,9 cm)

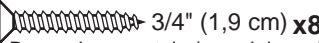
x1  48" Metal Threshold

x8  3/4" (1,9 cm) x8
 Bagged separately / special coating

FLOOR LEVELING OPTIONS

There are multiple ways to level your floor frame. Our recommended leveling method is shown below.
Leveling materials are not included in this kit.

PREFERRED METHOD - 4x4 TREATED RUNNERS

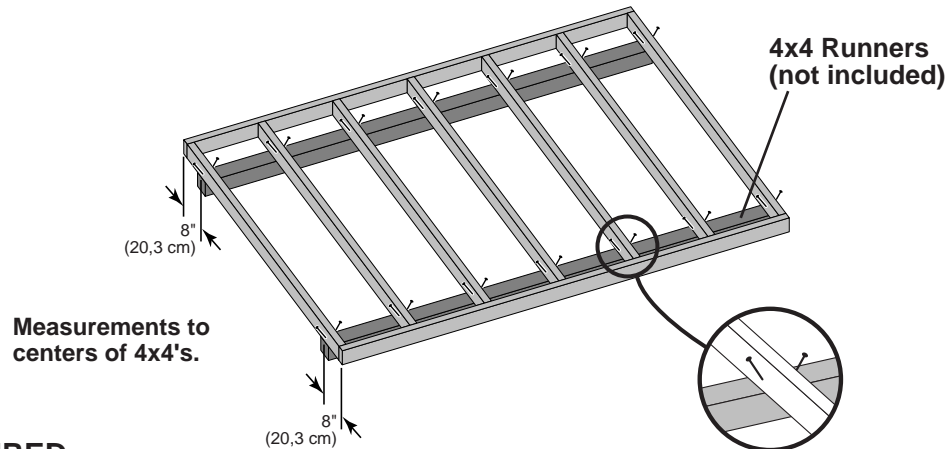

- 3" Screw angled into 4x4.
- (2) at each point frame and 4x4 touch.

MATERIAL REQUIRED

x2 4 x 4 x 8' (10,1 x 10,1 x 243,8 cm) Treated Lumber

Fasteners for Frame to 4x4.
(3" Screws shown as one option.) Minimum (28) 3" screws / exterior grade.

! Use only wood treated for ground contact and fasteners approved for use with treated wood.

! Always support frame seams.

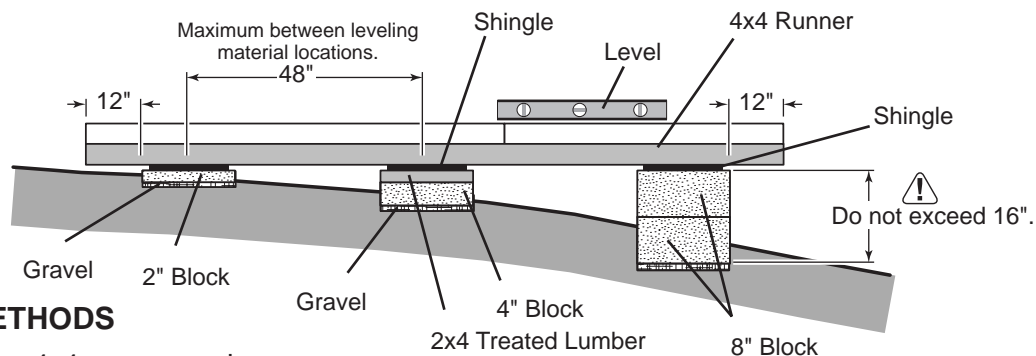

LEVELING METHODS

- Level under 4x4 runners only.
- Locate leveling material 12" from ends of runners and no more than 48" apart.
- Asphalt shingles should be used between 4x4 runners and blocks or treated lumber.
Never use shingles in direct contact with ground.
- For best results and aiding in water drainage use gravel under each concrete block.

LEVELING MATERIALS

- Gravel
- Solid Masonry Blocks in 1", 2", 4" or 8" thickness
- 2x4 Treated Lumber
- Asphalt Shingles

! Leveling higher than 16" not recommended.

CONCRETE

- If you are building your shed on a concrete foundation see the following page.

CONCRETE FOUNDATION

If you choose to install your kit on a concrete slab, refer to the diagram below.

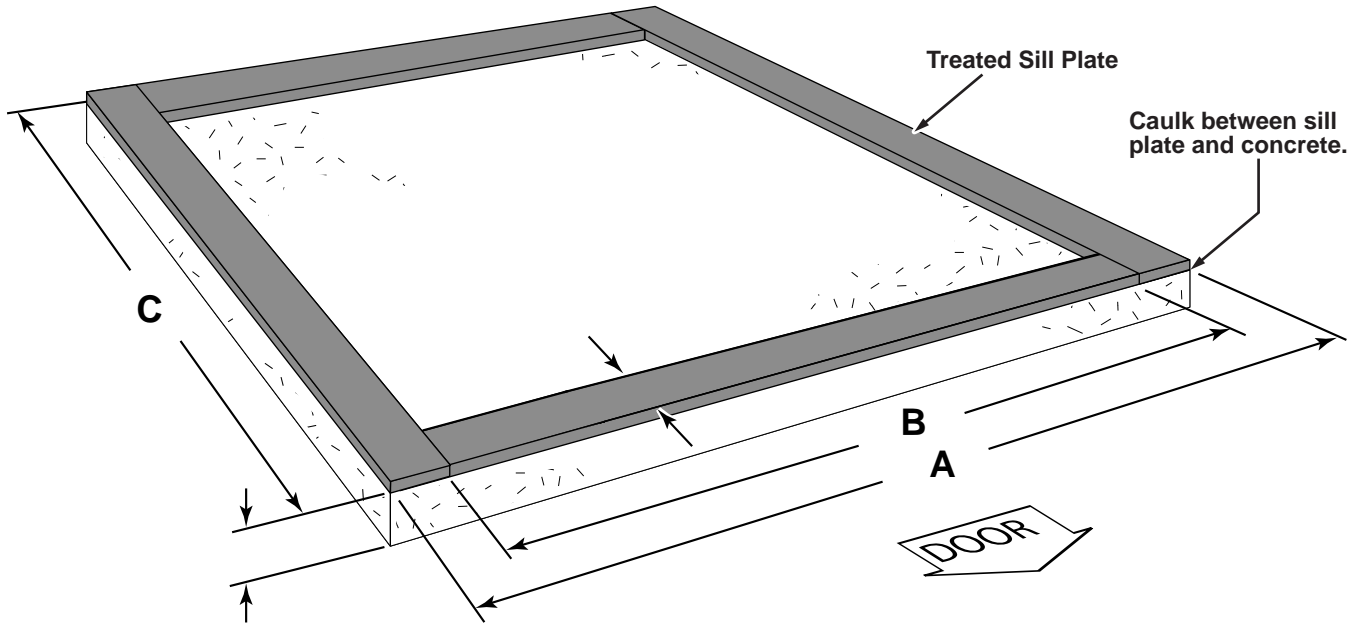

Building Size	Actual Size	A	B	C
6' x 8' (183 x 243,8 cm)	6' x 8' (182,9 x 243,8 cm)	72" (182,9 cm)	65" (165,1 cm)	96" (243,8 cm)

Use treated lumber supplied in kit.

- x2** 2 x 4 x 8' (5 x 10 x 243,8 cm) **MUST be treated lumber.**
- x2** 2 x 4 x 6' (5 x 10 x 182,9 cm) Cut to (2) 2 x 4 x 65" **MUST be treated lumber.**
- x1** Caulk

Allow new concrete slabs to cure for at least seven (7) days.

- A treated 2 x 4 (5,1 x 10,2 cm) sill plate is required when installing your shed on concrete.
- Use a high quality exterior grade caulk beneath all sill plates.
- Fasten 2 x 4 (5,1 x 10,2 cm) sill plates to slab using approved concrete anchors (**fasteners not included**).
- Check local code for concrete foundation requirements.

NOTES

FLOOR FRAME

PARTS REQUIRED:

x2 TREATED
2 x 4 x 96" (5 x 10 x 244 cm)

x7 TREATED
2 x 4 x 69" (5 x 10 x 175,3 cm)

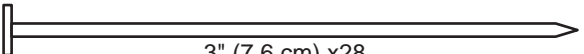
x28  3" (7,6 cm) x28

NOTE: Look for TREATED Stamp.

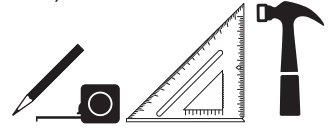

✓ BEGIN

1 Orient parts as shown on flat surface. Measure and mark each dimension from end of boards.

Secure using two 3" nails at each mark.

 **HINT:**
For easier nailing
stand on frame.

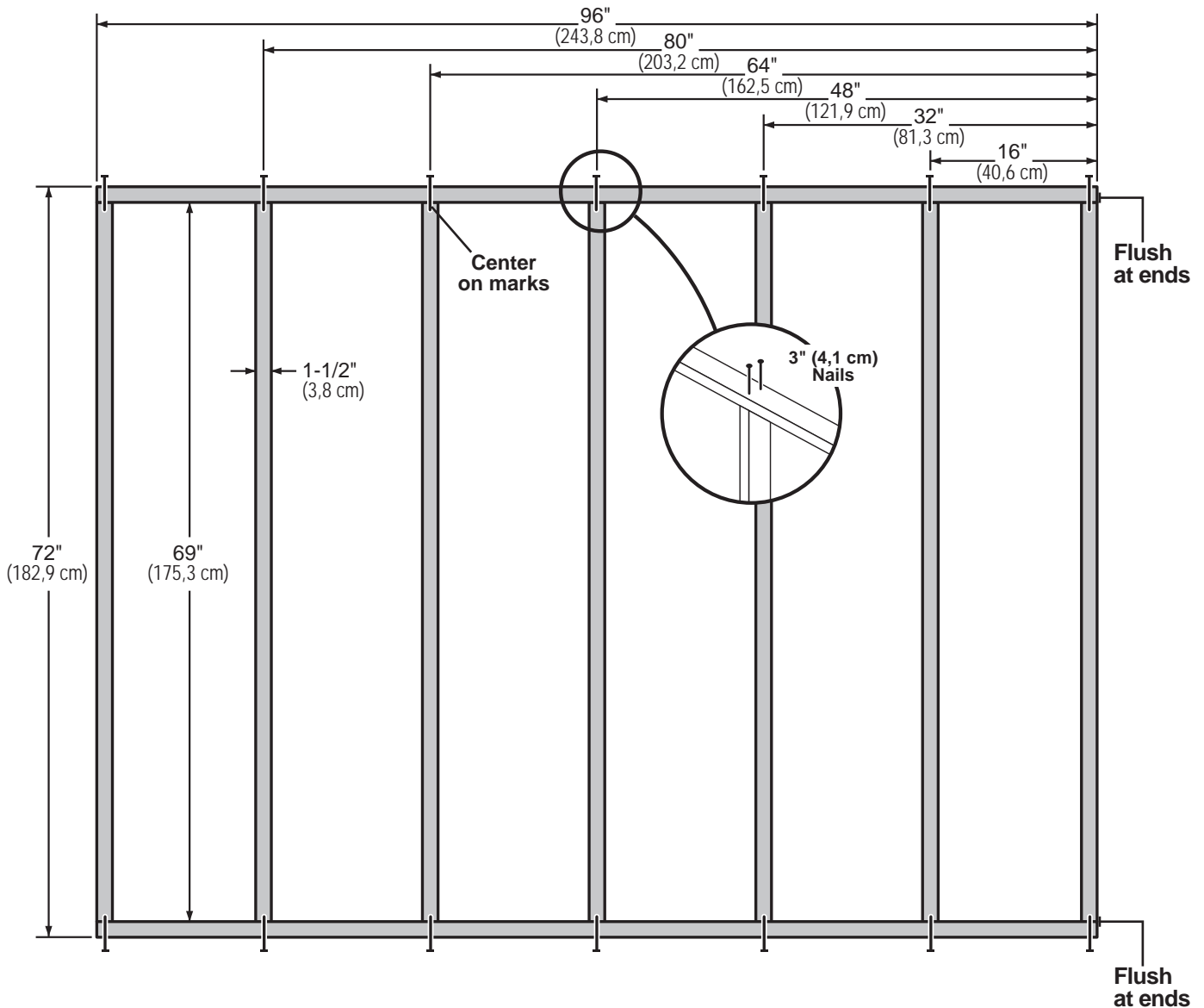
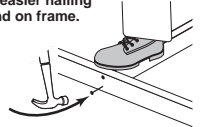

FINISH

You have finished your floor frame.

STOP!



LEVEL AND SQUARE FLOOR FRAME



STOP!

Before attaching floor decking, it is important to level and square the floor frame. A level and square floor frame is required to correctly construct your shed.

✓ **BEGIN**

- 1 See page 7 for the preferred floor leveling method.
- 2 Use level and check the frame is level before applying floor panels.
- 3 Check for frame squareness by measuring diagonally across corners. If the measurements are the same, the frame is square. The diagonal measurement will be approximately 120" (304,8 cm).
- 4 When the frame is level and square secure one side of frame to the 4x4 runners using one fastener at ends of each runner. Move to the opposite end of the frame. Secure the frame to 4x4 runners with one fastener at ends of each runner making sure the frame remains square (**Fig. A**).

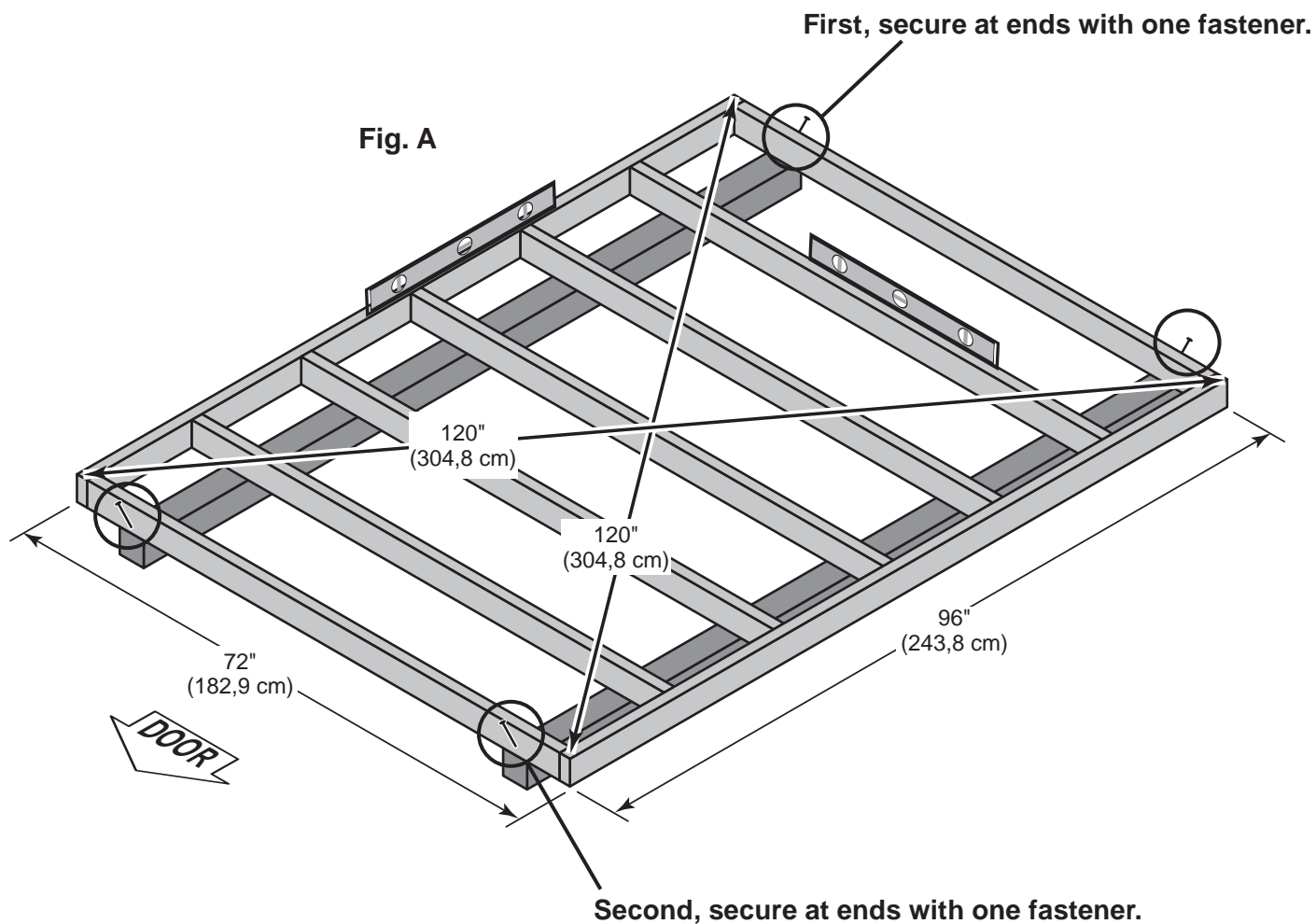

FINISH

Once the floor frame is level and square, fasten the frame to the 4x4 runners at each point the frame contacts the 4x4 runners.

FLOOR PANELS

PARTS REQUIRED:

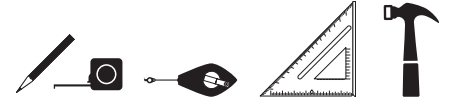
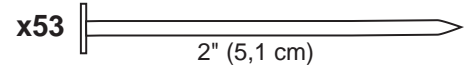
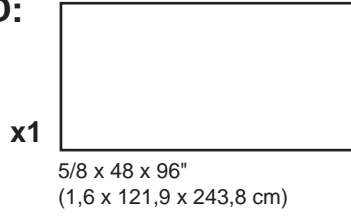

Install panels with rough side up (painted grid lines).

✓ **BEGIN**

- 1 Attach the 48 x 96" panel with the 48" edge and corner flush to the outside of the floor frame. Secure panel using using 2" nails 6" apart on edges and 12" apart inside panel.

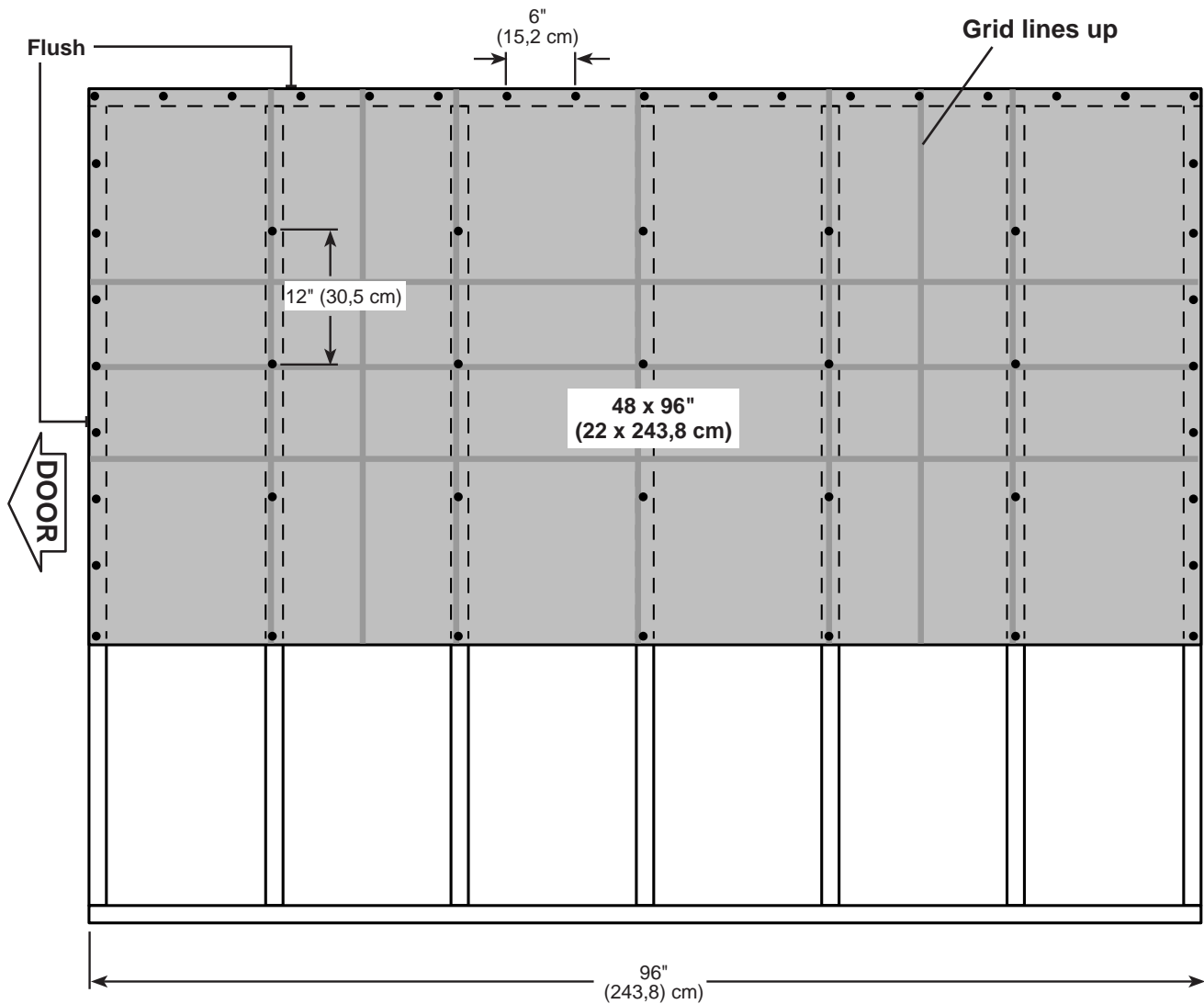

FLOOR PANELS

PARTS REQUIRED:

x1



5/8 x 23-7/8 x 96"
(1,6 x 60,6 x 243,8 cm)

x35 2" (5,1 cm)



- 5 Attach the **23-7/8 x 96"** panel with the 96" edge flush to the installed panel.
Secure panel using using 2" nails 6" apart on edges and 12" apart inside panel.

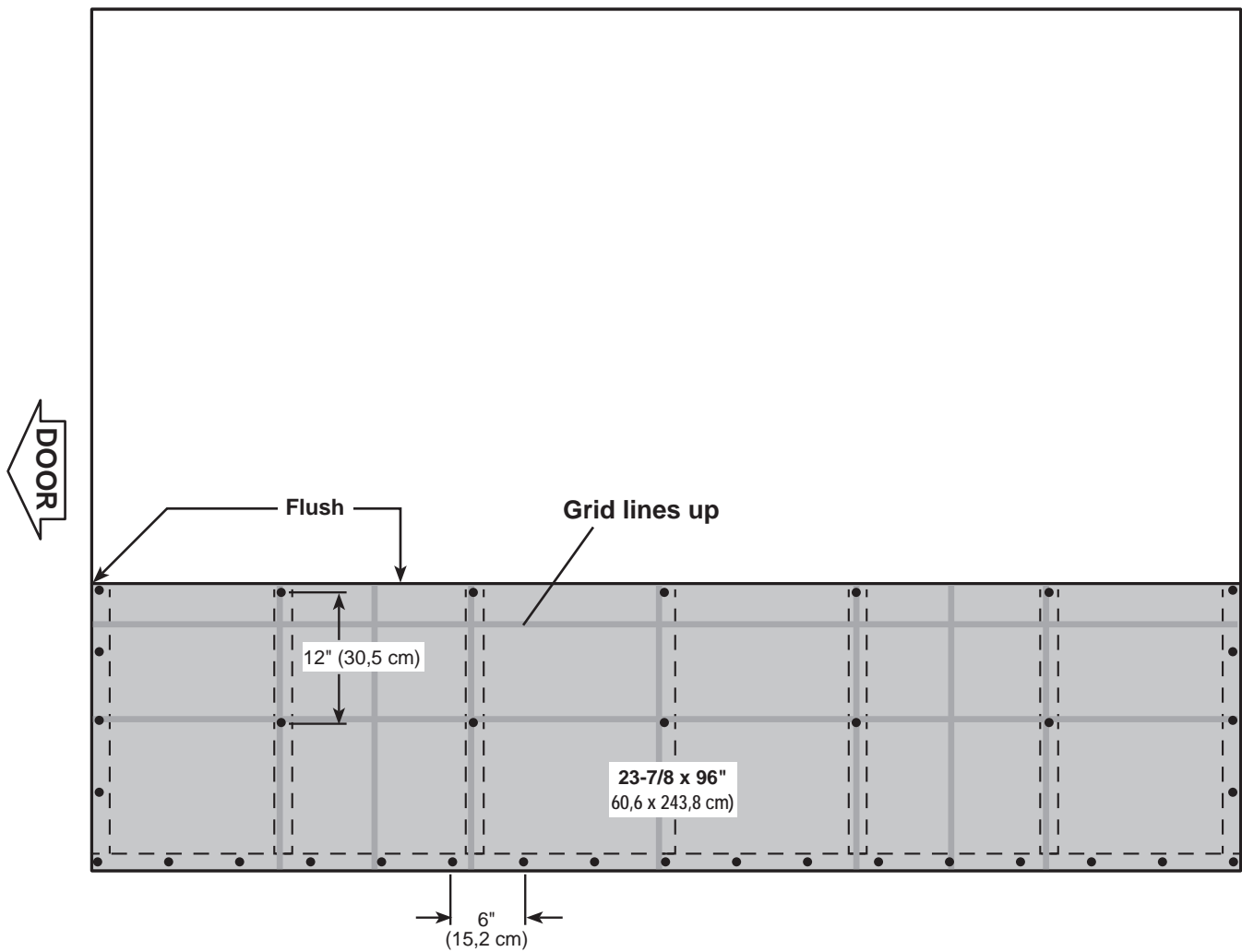

Your floor panels are now installed.

IMPORTANT!



Check that the floor frame is level after installing floor panels.
Re-level if needed.

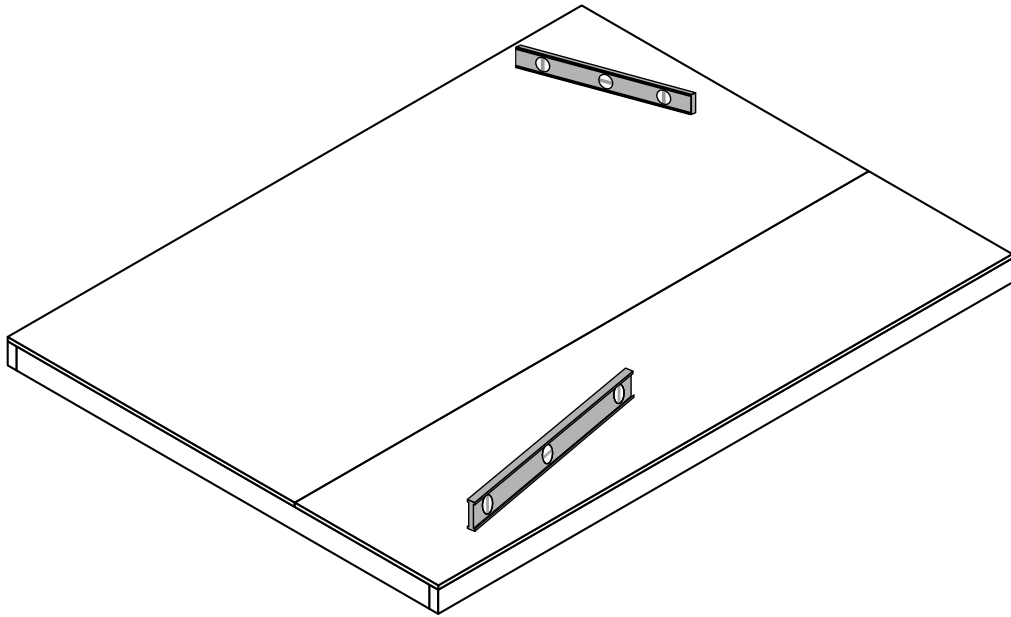

HINT:

- The floor should be used as a stable work surface for wall construction.
- Organize your assembly procedure during the build process to avoid over-handling of the walls.

BACK WALL

RIGHT WALL

RIGHT WALL

LEFT WALL

FRONT WALL

SIDE WALLS

PARTS REQUIRED:

x10 **UM**
2 x 4 x 68" (5,1 x 10,2 x 172,7 cm)

x4 **TP**
2 x 4 x 96" (5,1 x 10,2 x 243,8 cm)

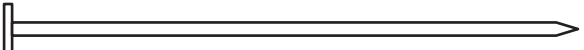
x40  3" (7,6 cm)



- BUILD TWO IDENTICAL SIDE WALLS -

✓ **BEGIN**

- 1 Orient parts on edge on floor. Measure and mark.
Use two 3" nails at each mark.

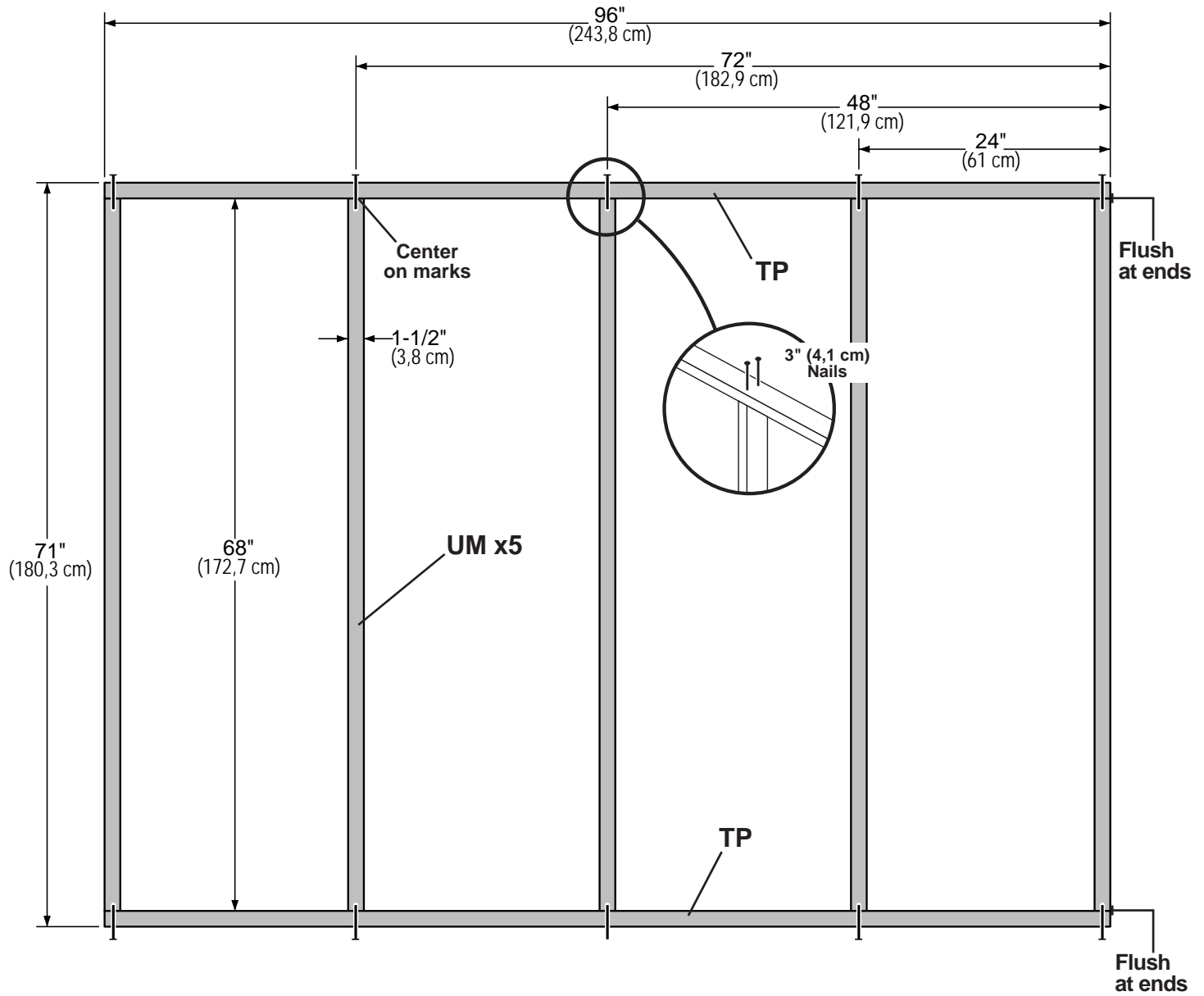

SIDE WALLS

PARTS REQUIRED:

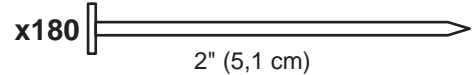
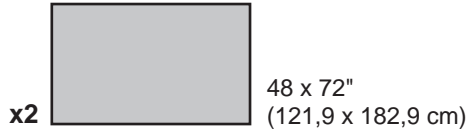

- Install 48 x 72" wall panels with primed side up as shown.
Secure panels to frame using 2" nails 6" apart along edges and 12" apart on inside of panel.

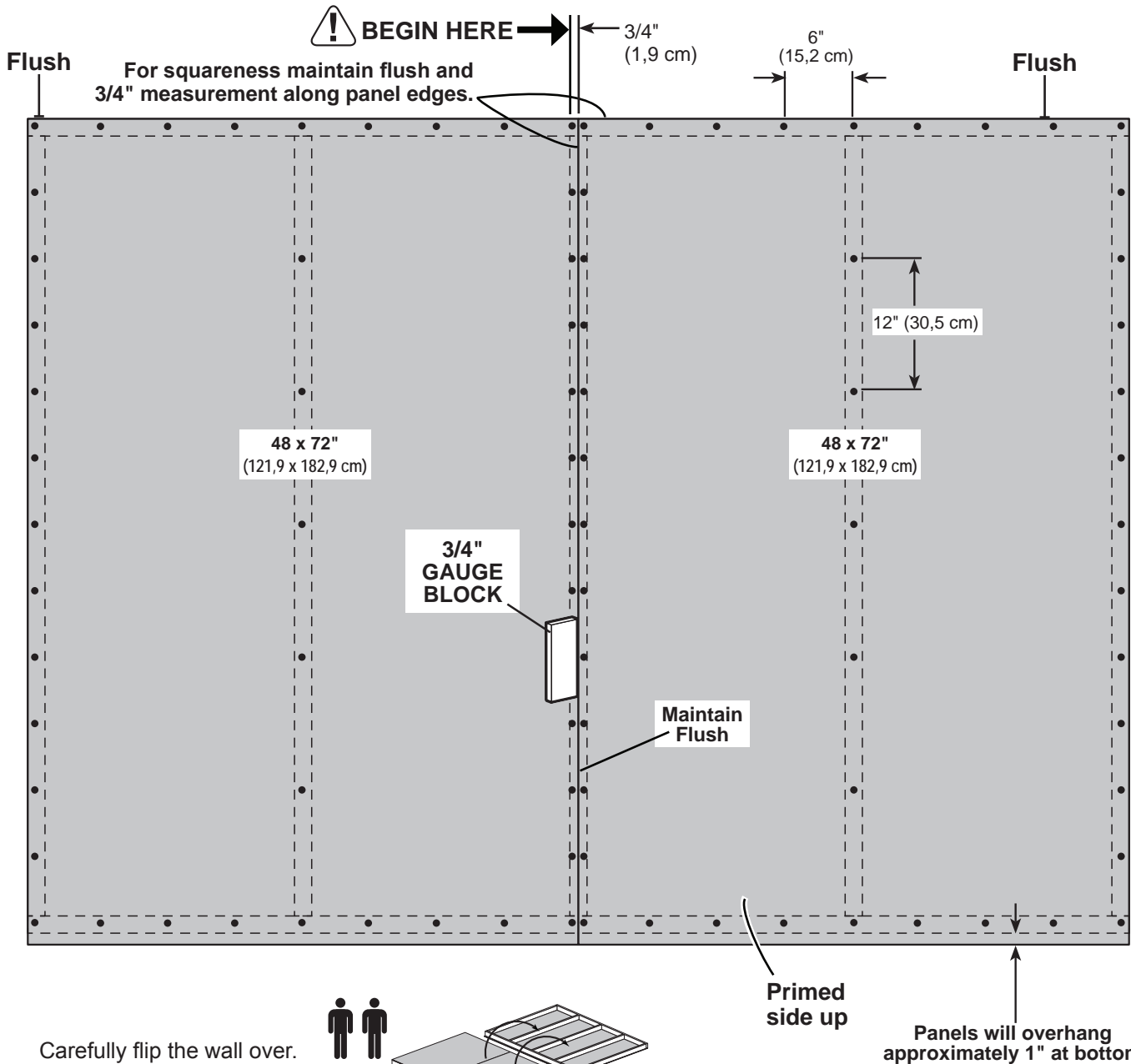

Repeat STEPS 1 - 2 to build your second side wall wall.



You have finished building your left and right side walls.

BACK WALL

PARTS REQUIRED:

x5 **UM**
2 x 4 x 68" (5,1 x 10,2 x 172,7 cm)

x2 **TJA**
2 x 4 x 65" (5,1 x 10,2 x 165,1 cm)

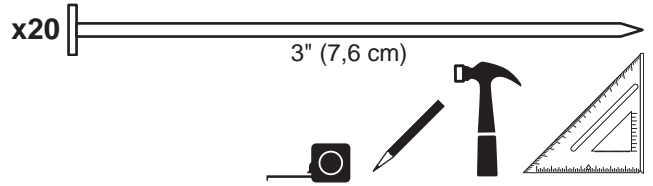

✓ **BEGIN**

- 1 Orient parts on edge on floor. Measure and mark.
Use two 3" nails at each mark.

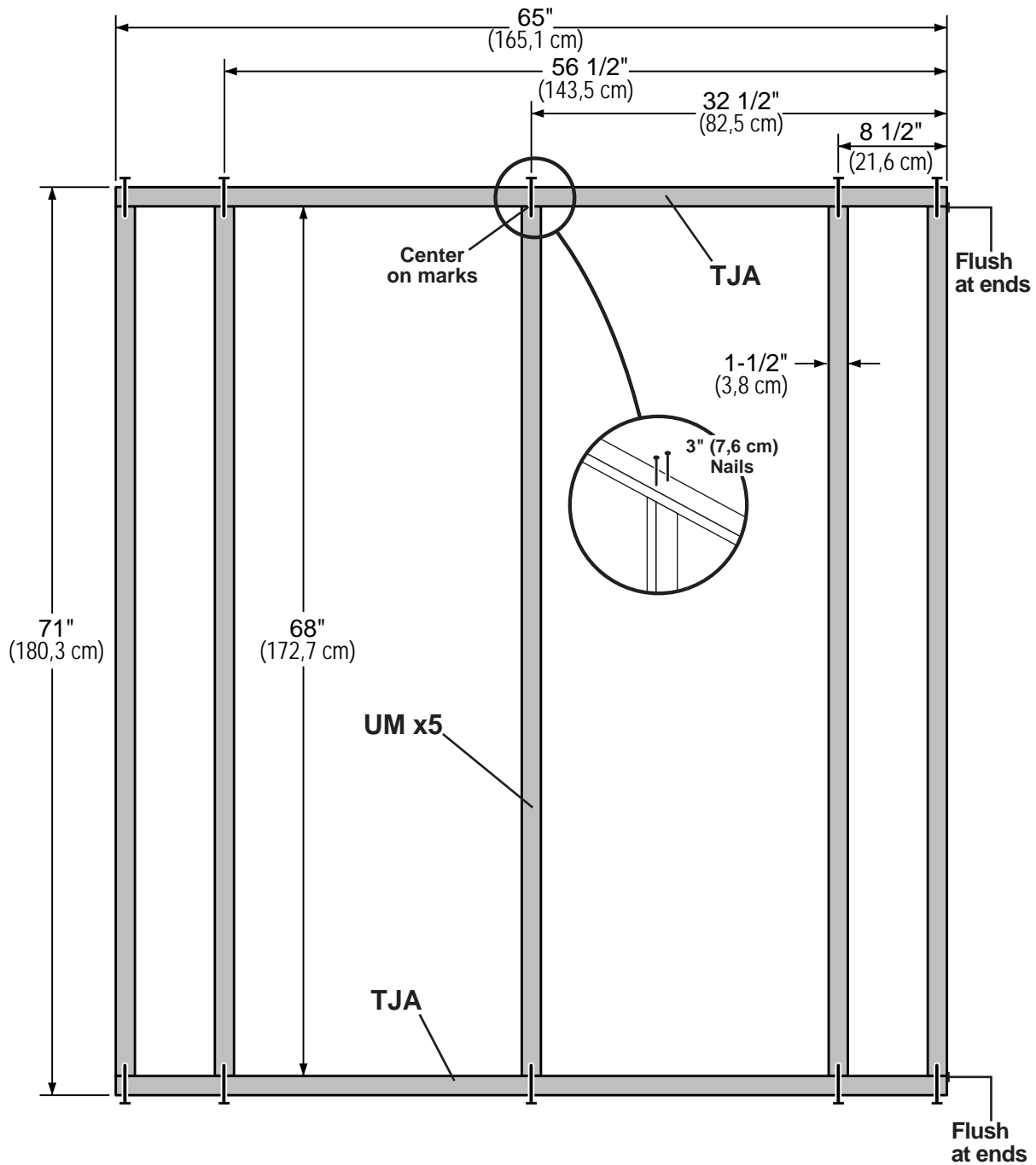

BACK WALL

PARTS REQUIRED:

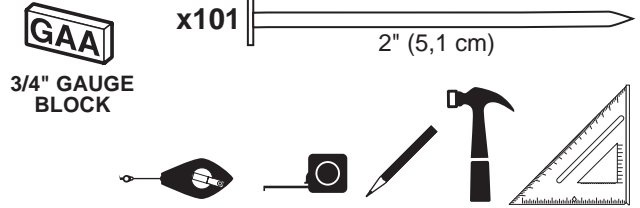
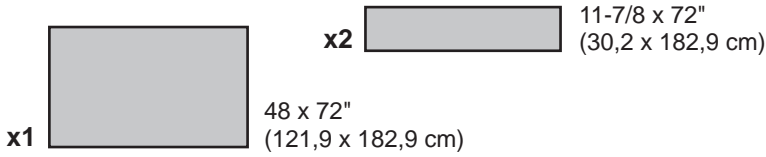

- Install back wall panels with primed side up as shown.
Secure panels to frame using 2" nails 6" apart along edges and 12" apart on inside of panel.

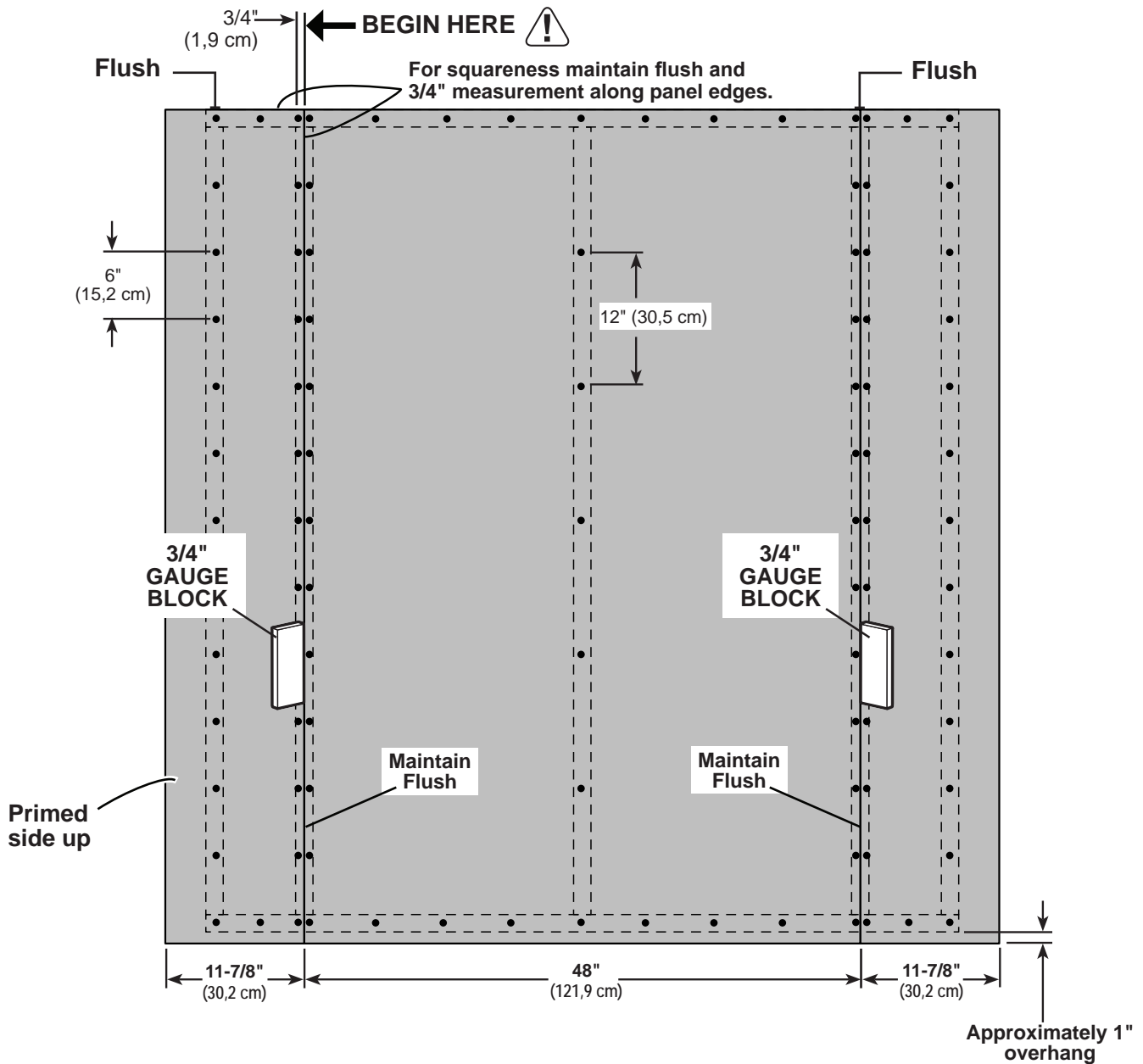

BACK WALL

PARTS REQUIRED:

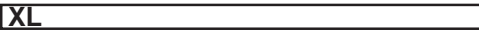
x1 XL  1 x 3 x 64" (2,5 x 7,6 x 162,5 cm)

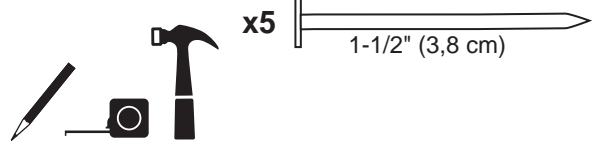

3 Center XL on back wall flush to the edge of wall top plate and wall panels (Fig. A, B).

Secure nailer using (5) 1-1/2" nails spaced evenly.

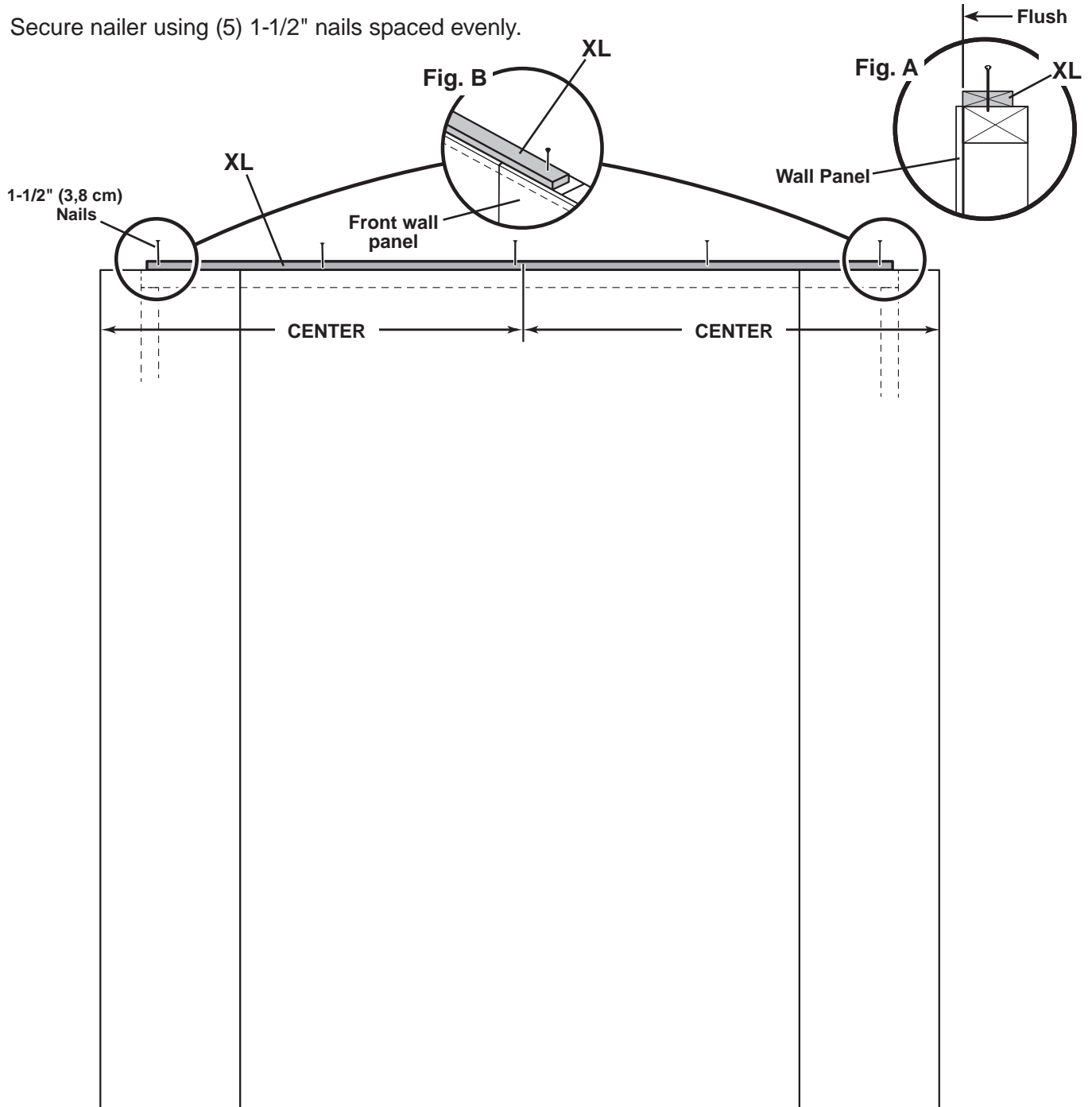

You have finished building your back wall.

Carefully flip the back wall over.

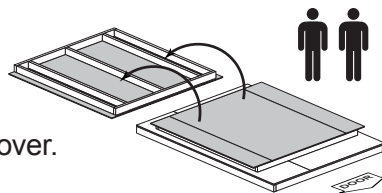

FRONT WALL

PARTS REQUIRED:

x2 **CPA** 2 x 4 x 8-1/2" (5,1 x 10,2 x 21,6 cm)

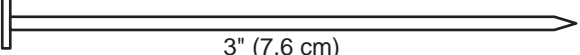
x16  3" (7,6 cm)

x1 **TJA** 2 x 4 x 65" (5,1 x 10,2 x 165,1 cm)

x4 **UM** 2 x 4 x 68" (5,1 x 10,2 x 172,7 cm)



✓ BEGIN

- 1 Orient parts on edge on floor. Measure and mark.
Use two 3" nails at each mark.

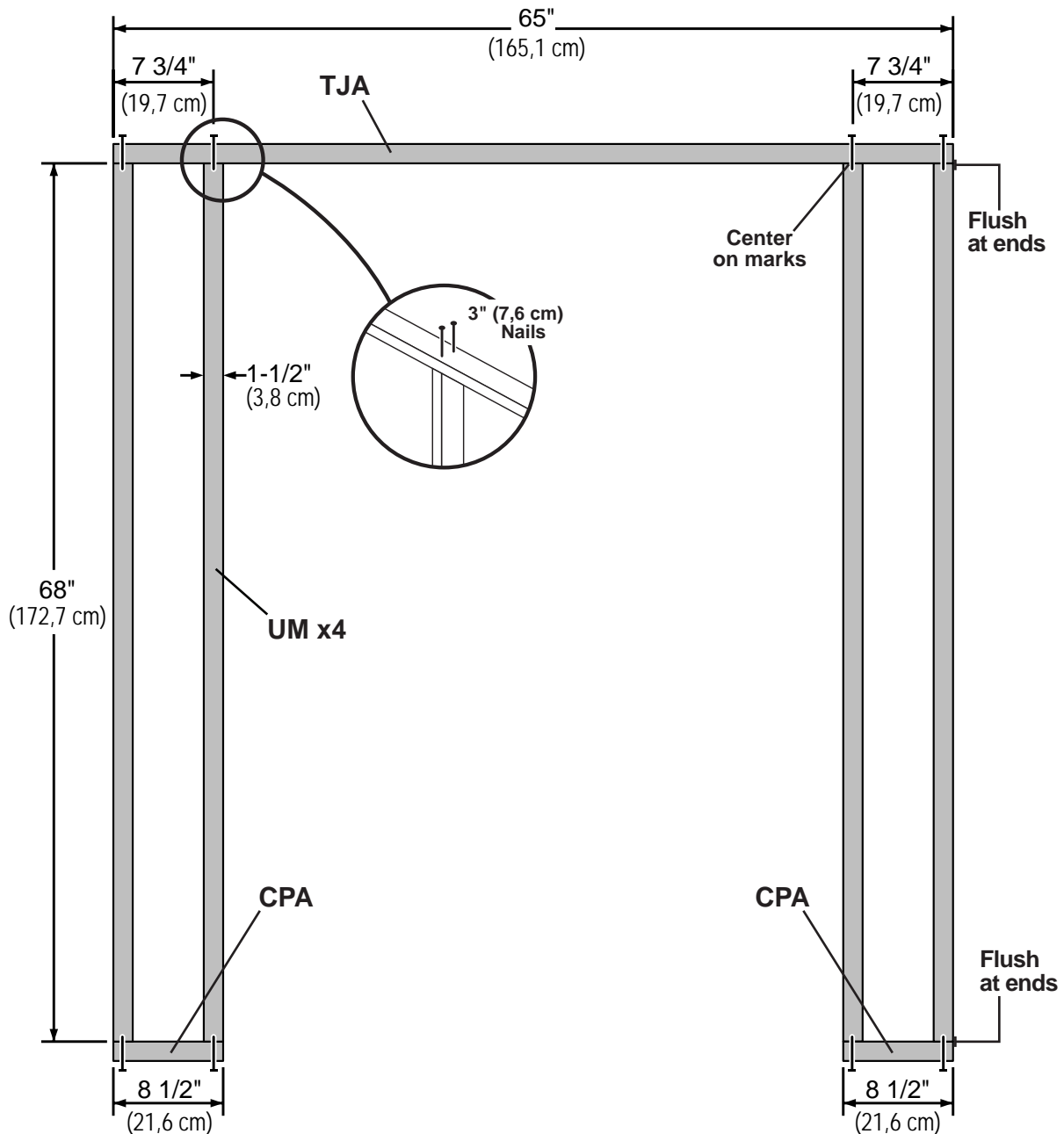

FRONT WALL

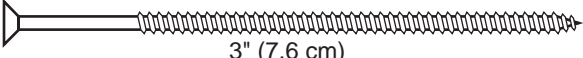
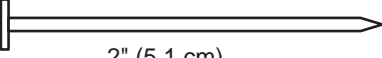
PARTS REQUIRED: x2  3" (7,6 cm) x56  2" (5,1 cm)

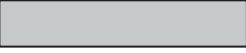
x2  11-7/8 x 72
(30,2 x 182,9 cm)

x1  **TEMPORARY SUPPORT** Door Stiffener 69" (175,3 cm)



- 2 Place 11-7/8" x 72" panels primed side up onto wall frame flush to top and along edges as shown. Secure panels with 2" nails 6" apart.
- 3 Attach temporary support OO to frame as shown using 3" screws.

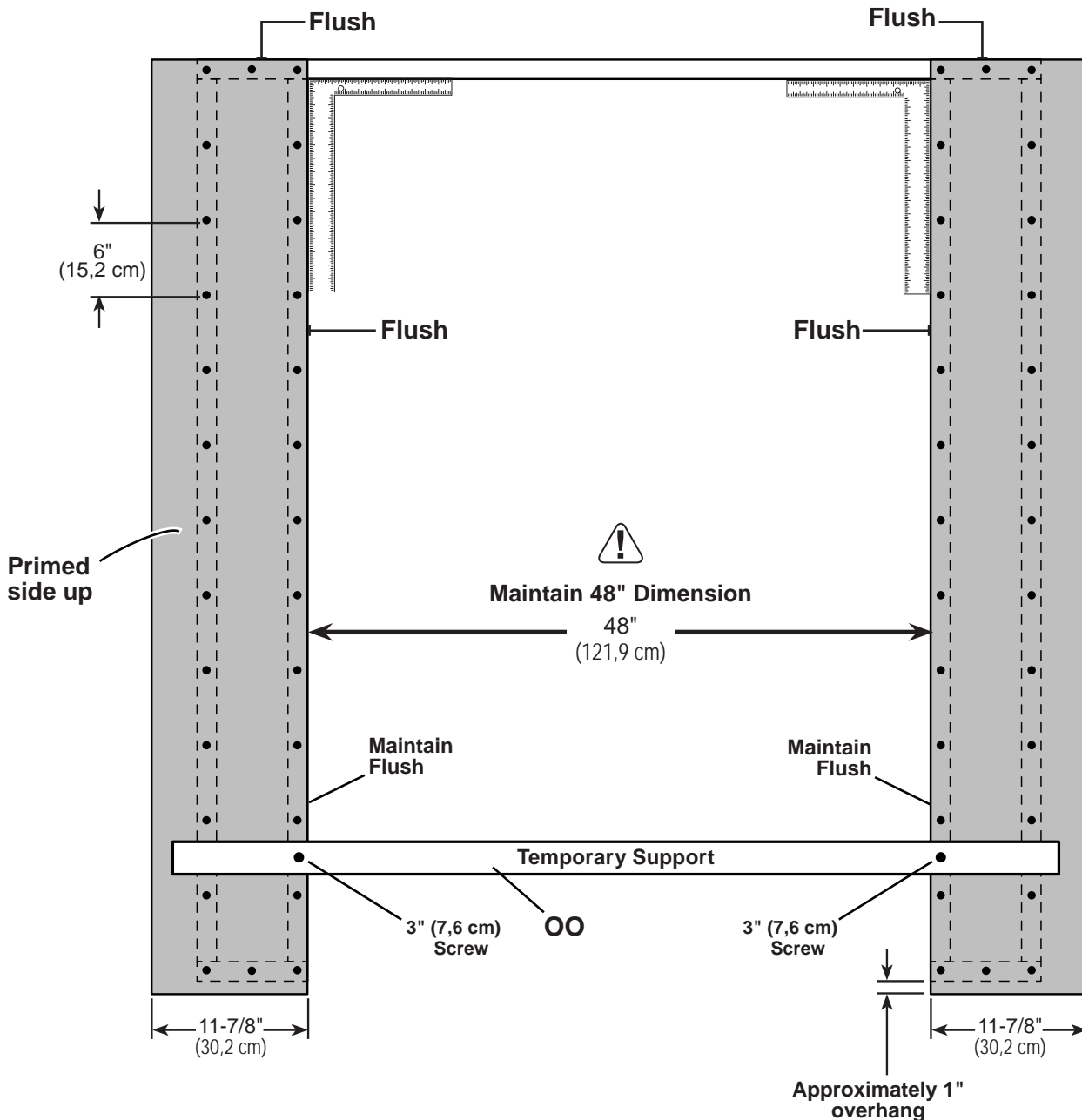

FRONT WALL

PARTS REQUIRED:

x1 **XL**  1 x 3 x 64" (2,5 x 7,6 x 162,5 cm)

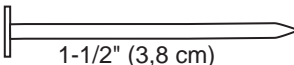

x5  1-1/2" (3,8 cm)

4 Center **XL** on back wall flush to the edge of wall top plate and wall panels (**Fig. A, B**).

Secure nailer using (5) 1-1/2" nails spaced evenly.

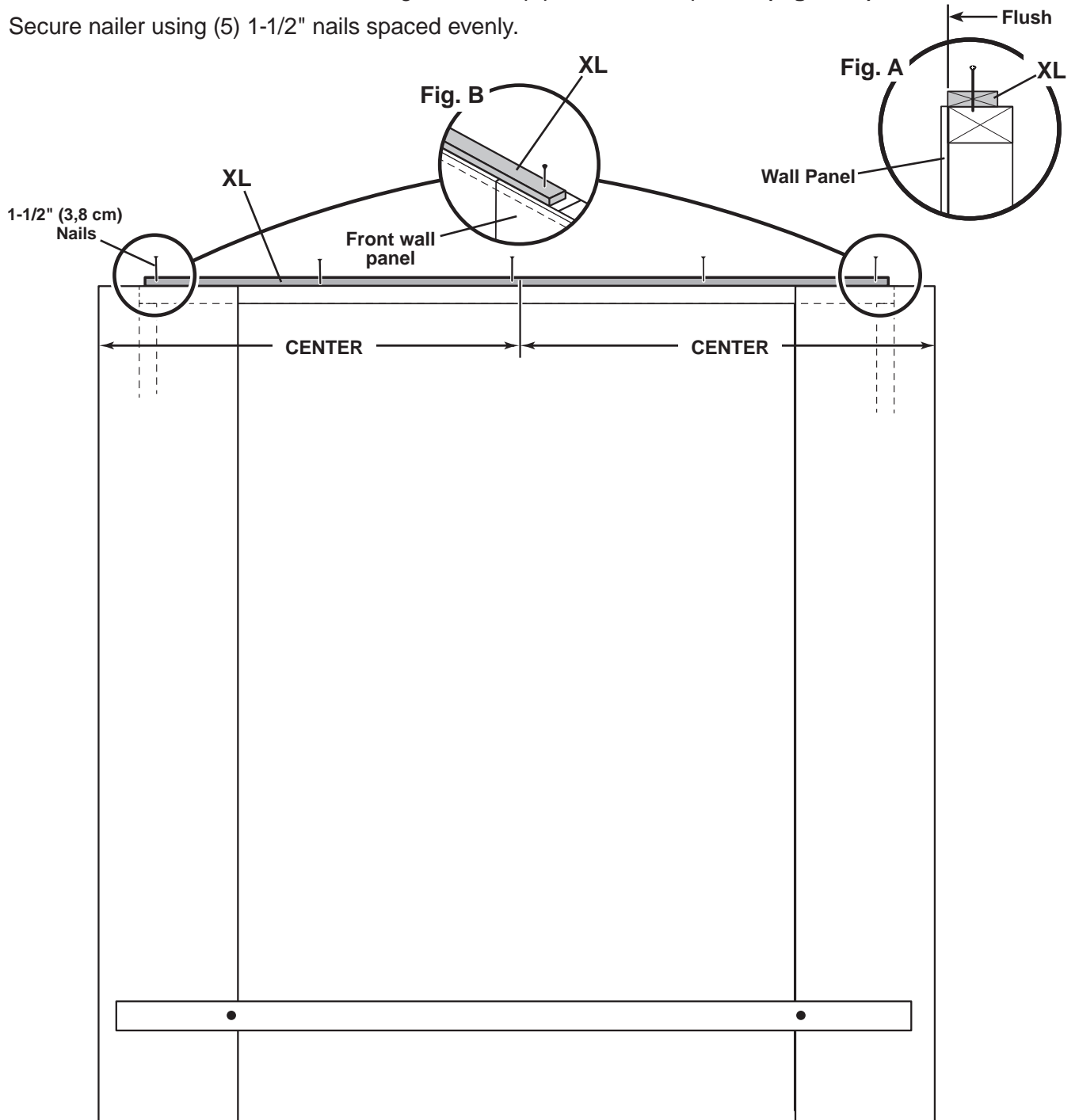

You have finished building your front wall.

Carefully flip the front wall over.

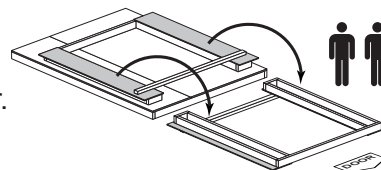

RIGHT WALL INSTALLATION

PARTS REQUIRED:

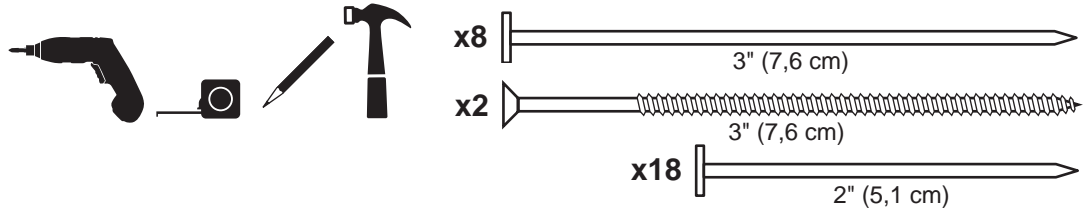

✓ BEGIN

- 1 Center right side wall assembly on the 96" floor dimension. 
- 2 Use TP as a temporary brace. Secure with (2) 3" screws.

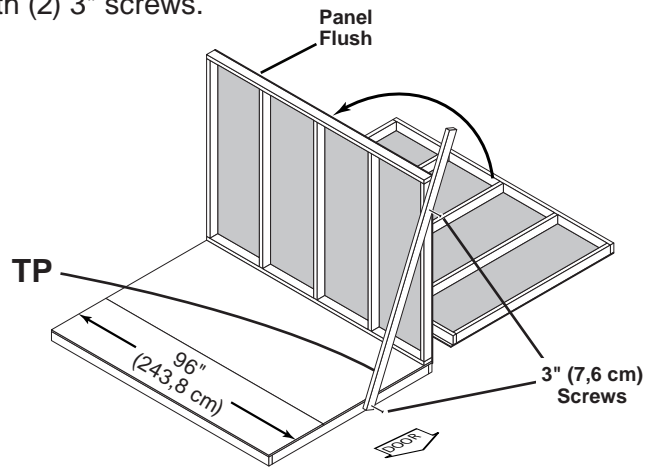

- 3 Nail lower edge of panel to floor frame using 2" nails 6" apart. Angle nail to hit floor frame (**Fig. A**).

Secure wall bottom plates to floor using 3" nails (**Fig. A**).

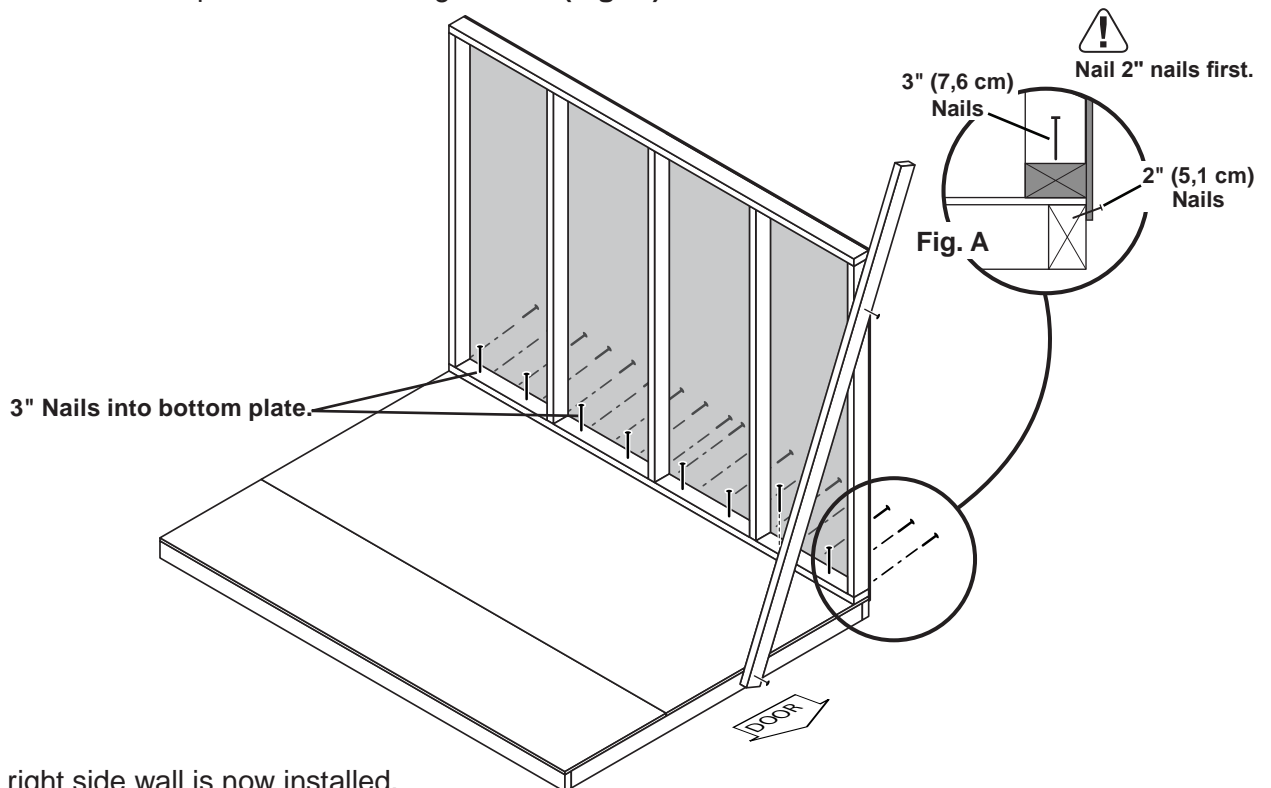

Your right side wall is now installed.

BACK WALL INSTALLATION

PARTS REQUIRED:

- x15 2" (5,1 cm)
- x2 2" (5,1 cm)

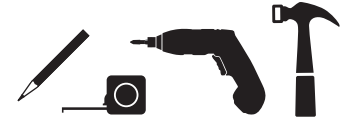

1 Center back wall assembly on the 72" dimension of floor.

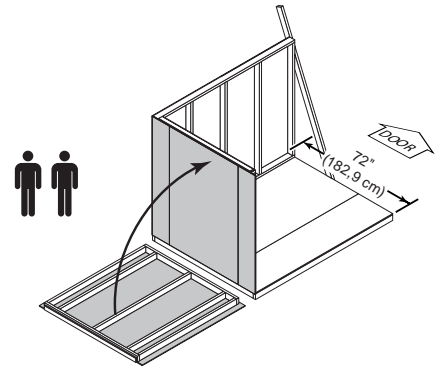

2 Secure back wall to side walls using one 2" screw into side wall top and bottom plate (Fig. A).

⚠ ENSURE TOP OF WALL FRAMES ARE FLUSH.

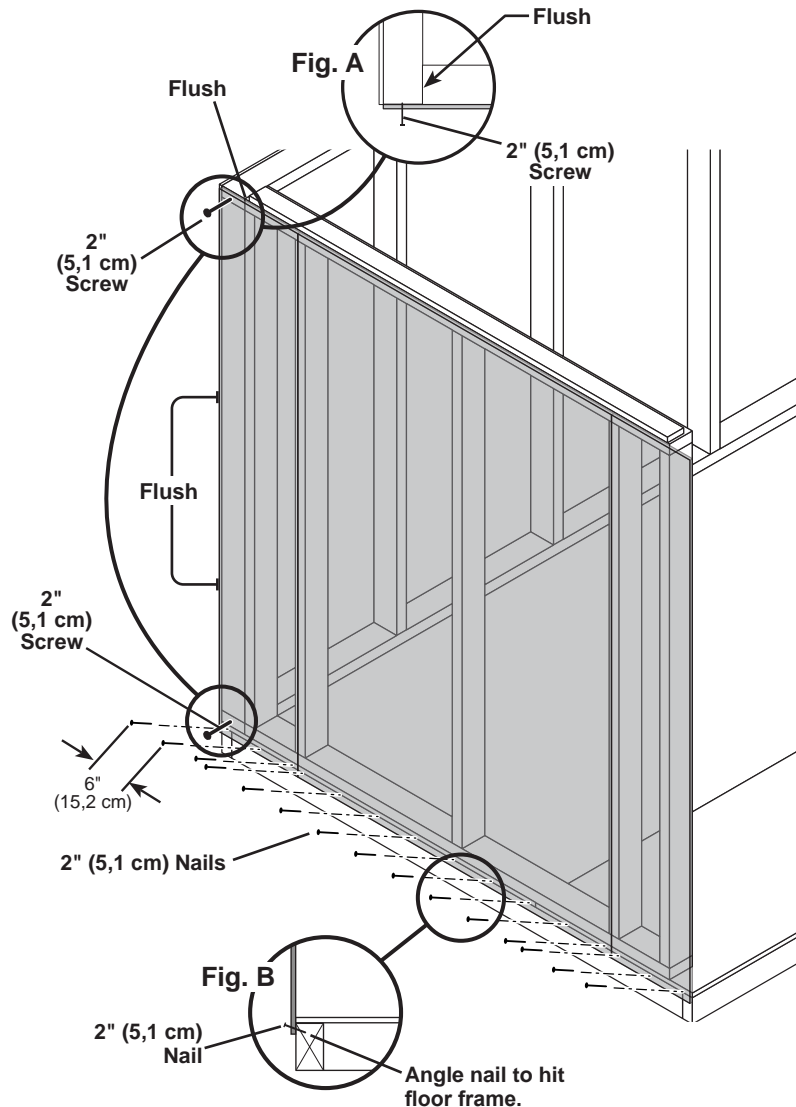

3 Nail lower edge of back wall panels to floor using 2" nails 6" apart. Angle nail to hit floor frame (Fig. B).

BACK WALL INSTALLATION

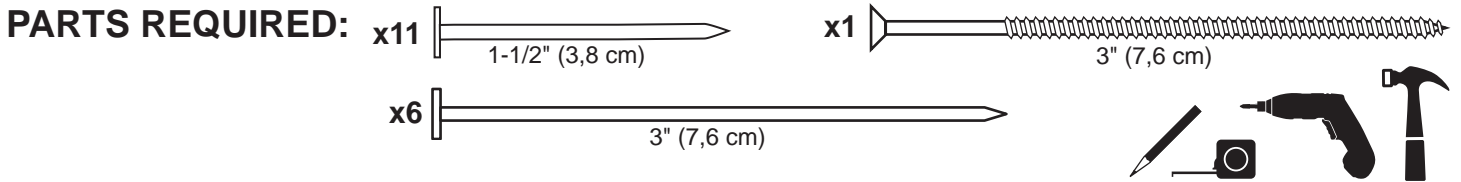

- 4 Nail back wall panel to side wall stud using 1-1/2" nails 6" apart (**Fig. C**).
Secure back wall top plate using (1) 3" screw into side wall top plate at an angle (**Fig. D**).
Secure back wall to floor using 3" nails (**Fig. C**).

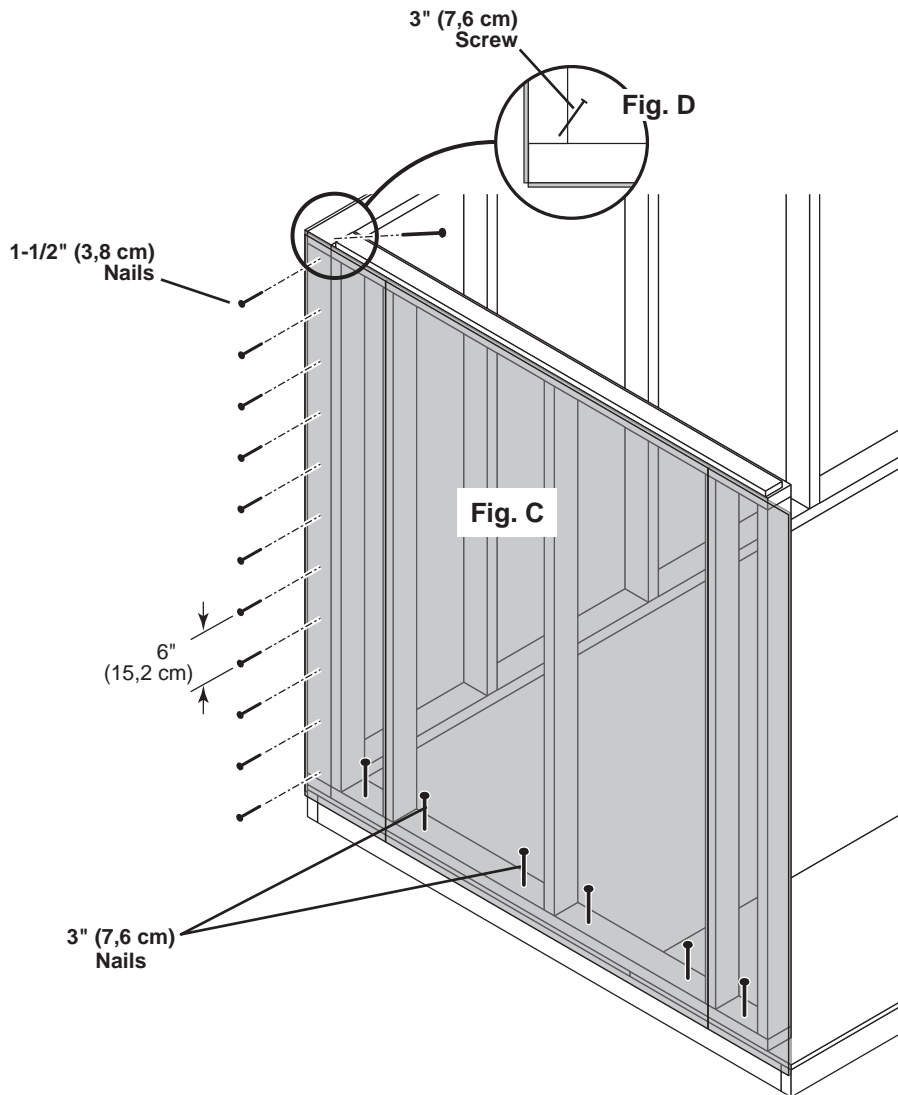

Your back wall is now installed.

LEFT WALL INSTALLATION

PARTS REQUIRED:

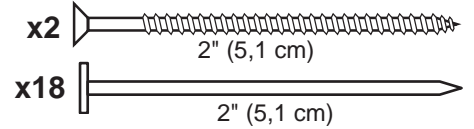
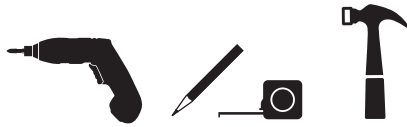

✓ **BEGIN**



1 Center left side wall assembly on the 96" floor dimension.

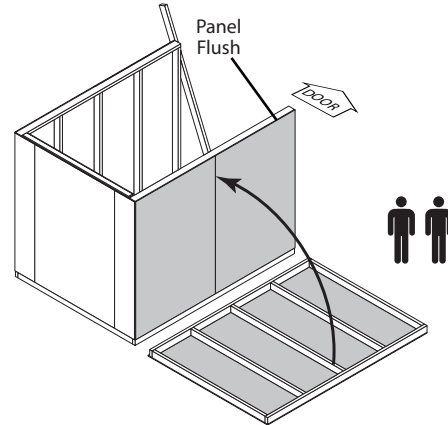

2 Secure back wall to side wall using one 2" screw into side wall top and bottom plate (**Fig. A**).

! ENSURE TOP OF WALL FRAMES ARE FLUSH.

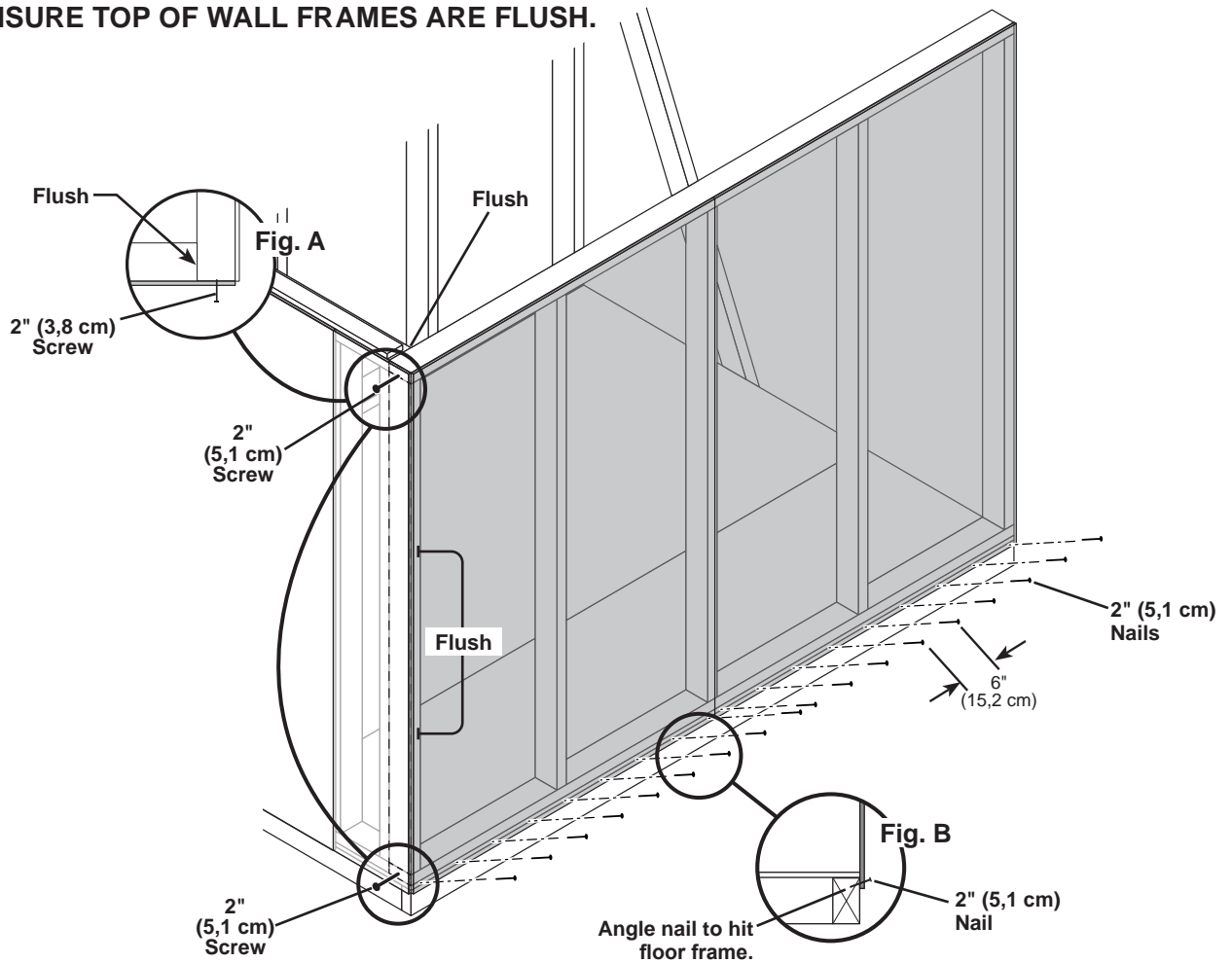

3 Nail lower edge of side wall panels to floor using 2" nails 6" apart. Angle nail to hit floor frame (**Fig. B**).

! ENSURE BACK AND SIDE WALL PANELS ARE FLUSH BEFORE SECURING.

LEFT WALL INSTALLATION

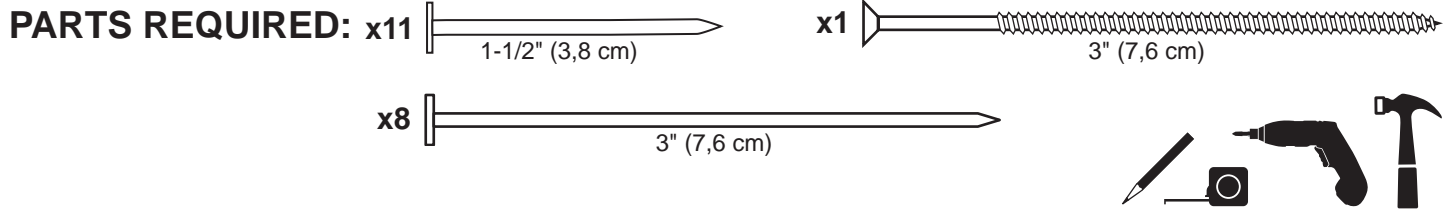

4 Nail back wall panel to side wall stud using 1-1/2" nails 6" apart (**Fig. C**).

Secure back wall top plate using (1) 3" screw into side wall top plate at an angle (**Fig. D**).

Secure side wall to floor using 3" nails (**Fig. C**).

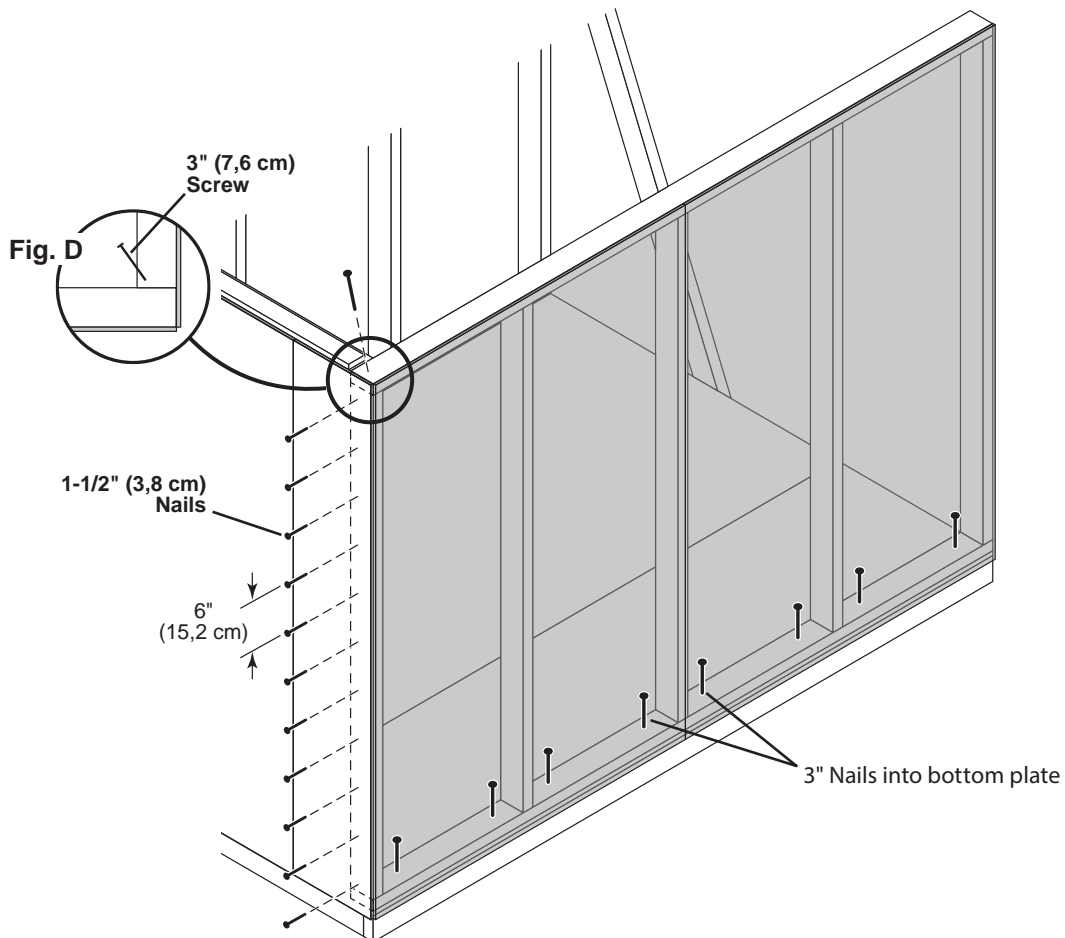

Your left side wall is now installed.

FRONT WALL INSTALLATION

PARTS REQUIRED:

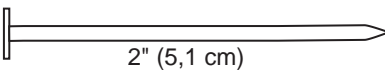
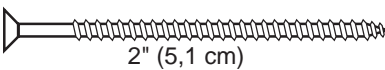
- x4  2" (5,1 cm)
- x4  2" (5,1 cm)



✓ BEGIN



- 1 Remove temporary wall support.
Center front wall assembly between the side walls.

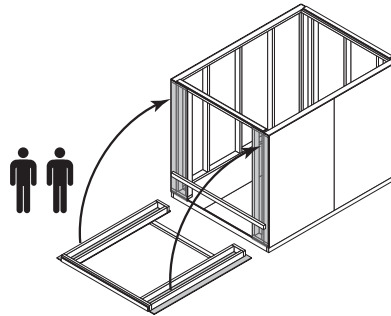

- 2 Secure front wall to side walls using one 2" screw into top and bottom plates (**Fig. A**).

⚠ ENSURE TOP OF WALL FRAMES ARE FLUSH.

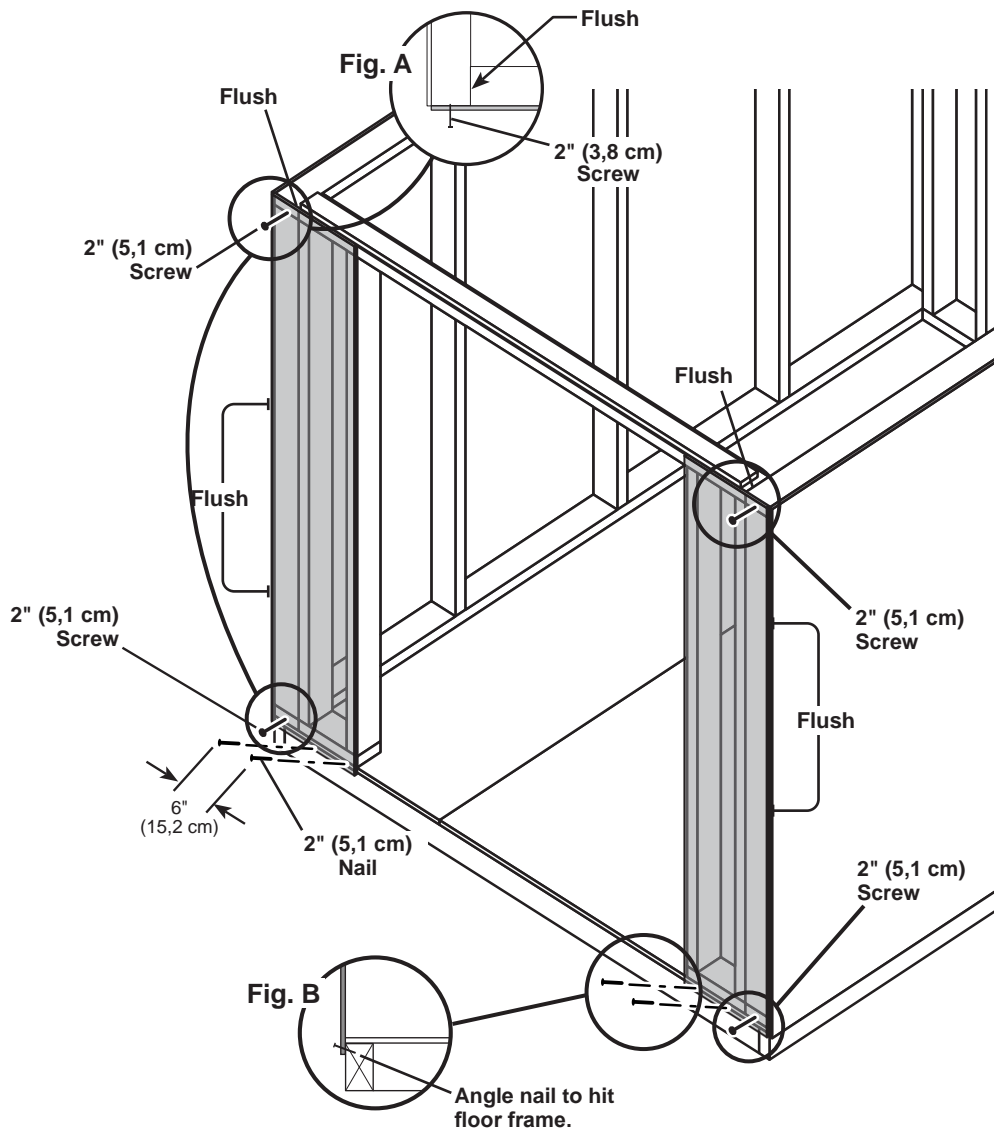

- 3 Nail lower edge of front wall panels to floor using 2" nails 6" apart. Angle nail to hit floor frame (**Fig. B**).

⚠ ENSURE FRONT AND SIDE WALL PANELS ARE FLUSH BEFORE SECURING.

FRONT WALL INSTALLATION

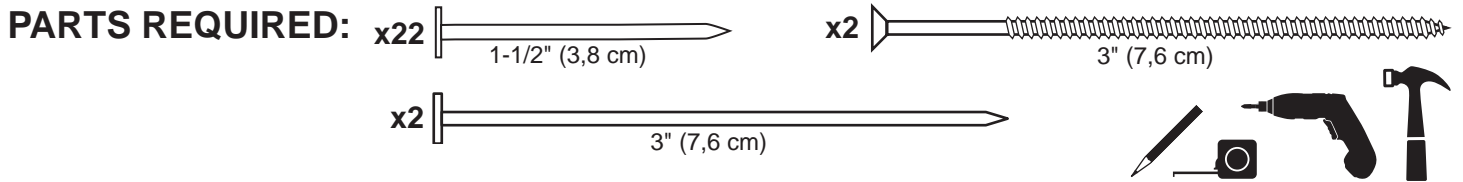

4 Nail front wall panel to side wall studs using 1-1/2" nails 6" apart (**Fig. C**).

Secure front wall top plates using (2) 3" screws into side wall top plates at an angle (**Fig. D**).

Secure front wall to floor using 3" nails (**Fig. C**).

Remove temporary brace.

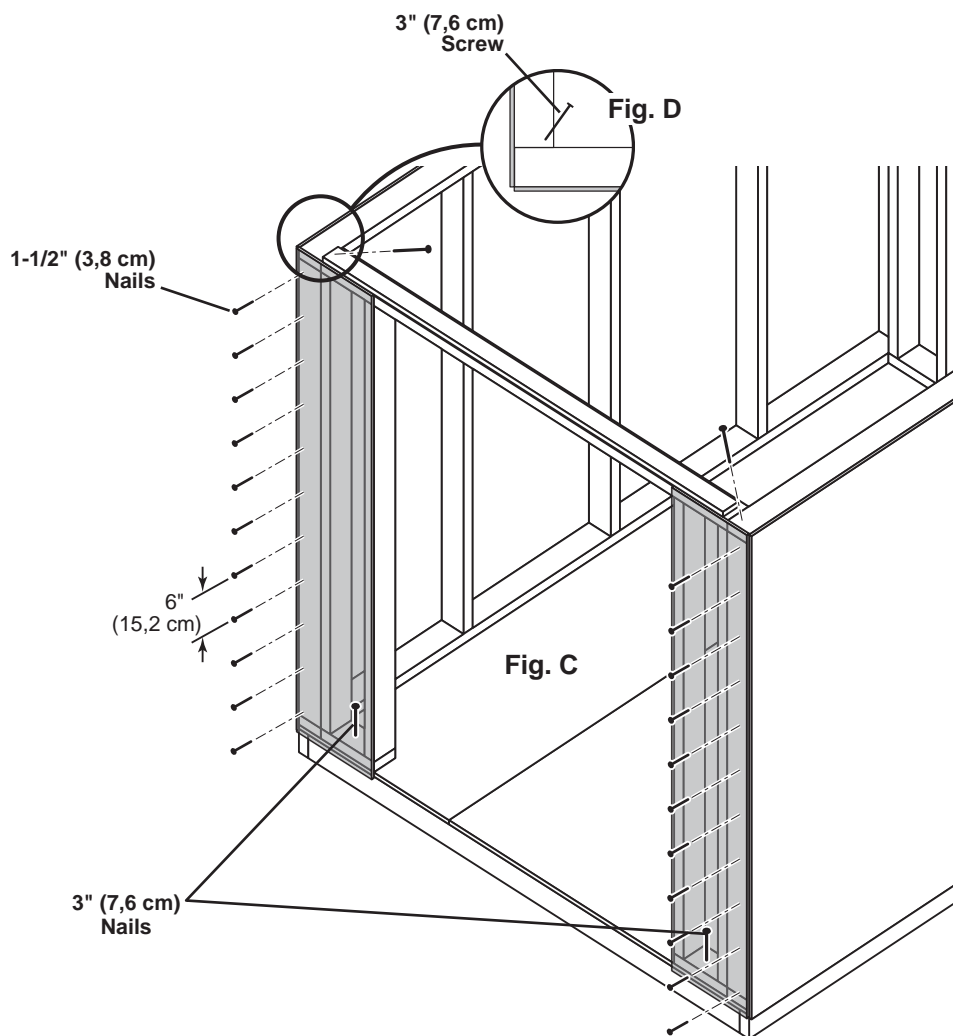

Your front wall is now installed.

SQUARING THE WALLS

PARTS REQUIRED:



x1 2 x 4

x1 2 x 4

You must square the walls after they are standing.

The 120" dimension is taken from the outside of the framing (Fig. A).

A square shed means you will have a straight and professional looking roof.

ALL WALLS MUST BE:

- LEVEL
- PLUMB
- SQUARE

THE FINAL DIMENSIONS WILL BE EQUAL:

- CORNER TO CORNER

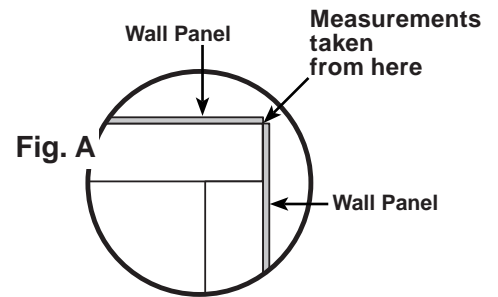
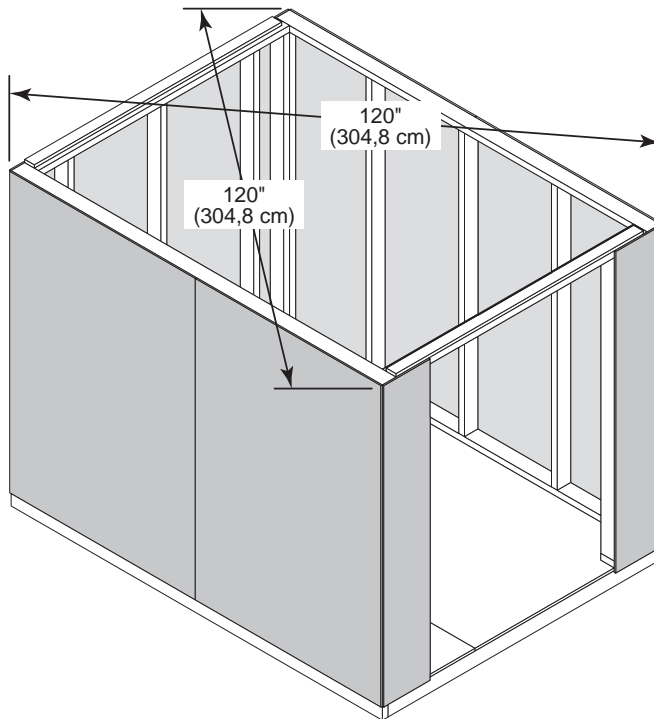

✓ BEGIN

- 1 Determine which corner of your shed needs to be lifted to bring the walls into square. Use the method below to help lift the floor up to level.

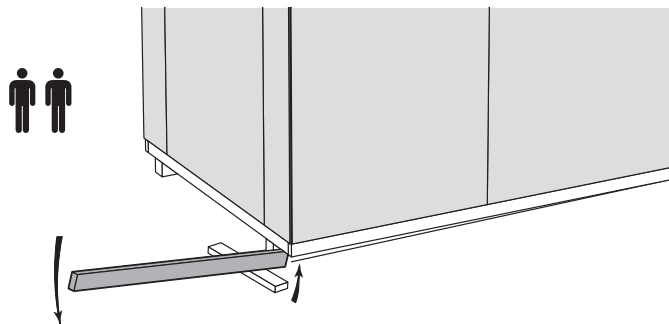

- 2 Once you have equal dimensions add shims under the floor to keep your shed square.

FINISH

Your shed is now square and level.

FRONT WALL GABLE

PARTS REQUIRED:

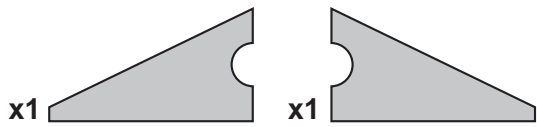

x2 **SFA**
2 x 3 x 4-7/8" (5,1 x 7,6 x 12,4 cm)

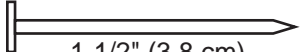
x8 
1-1/2" (3,8 cm)



✓ BEGIN

- 1 Orient parts **SFA** on flat as shown.
- 2 Place **LEFT** front gable panel as shown. Secure using 1-1/2" nails as shown

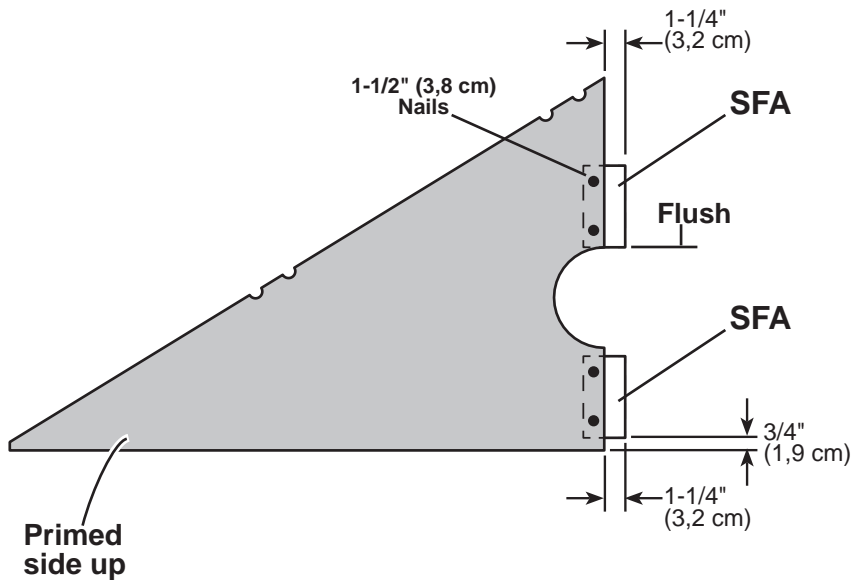

- 3 Place **RIGHT** front gable panel flush to left panel. Secure using 1-1/2" nails.

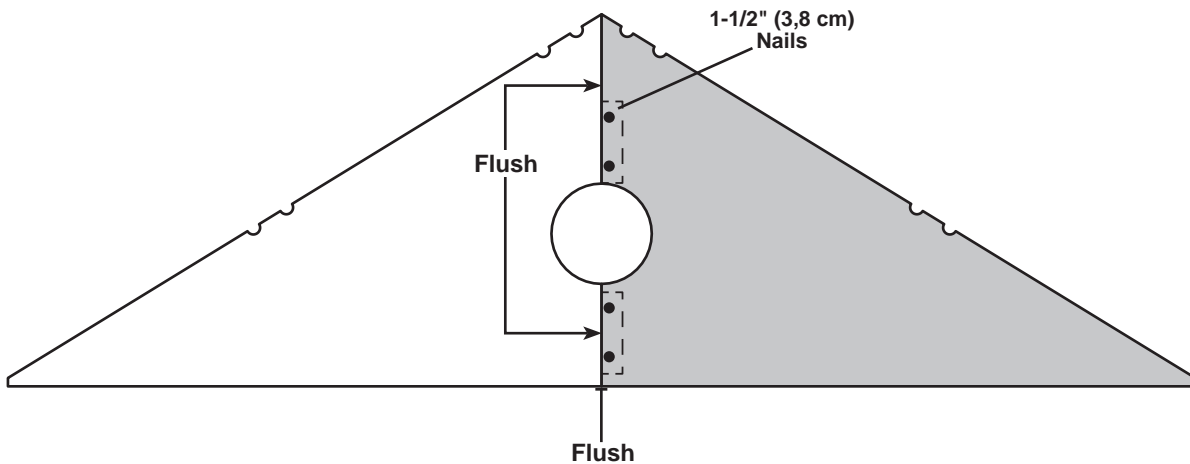

You have finished assembling your front wall gable.

BACK WALL GABLE

PARTS REQUIRED:

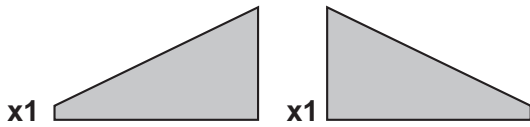

x1 **LN**
2 x 3 x 16-1/2" (5,1 x 7,6 x 41,9 cm)

x6
1-1/2" (3,8 cm)



✓ BEGIN

- 1 Orient part **LN** on flat as shown.
- 2 Place **LEFT** back gable panel as shown. Secure using 1-1/2" nails as shown

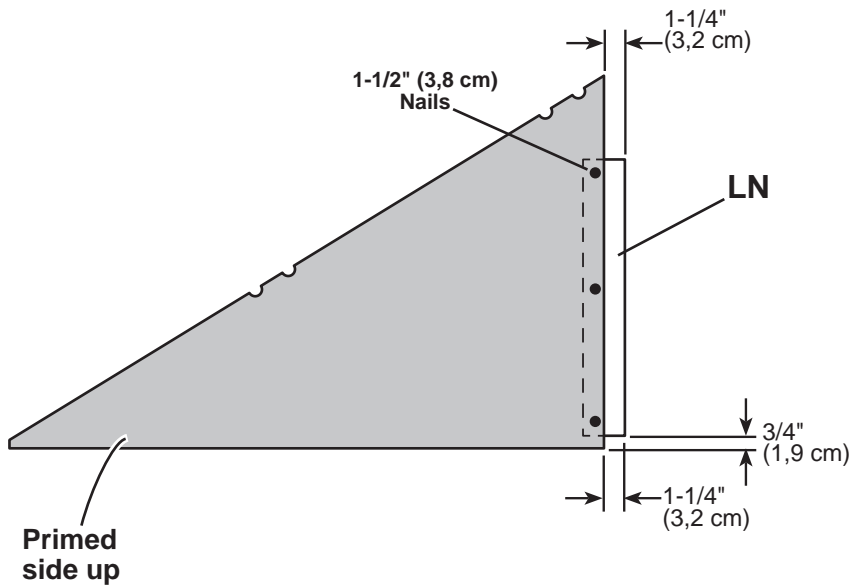

- 3 Place **RIGHT** back gable panel flush to left panel. Secure using 1-1/2" nails.

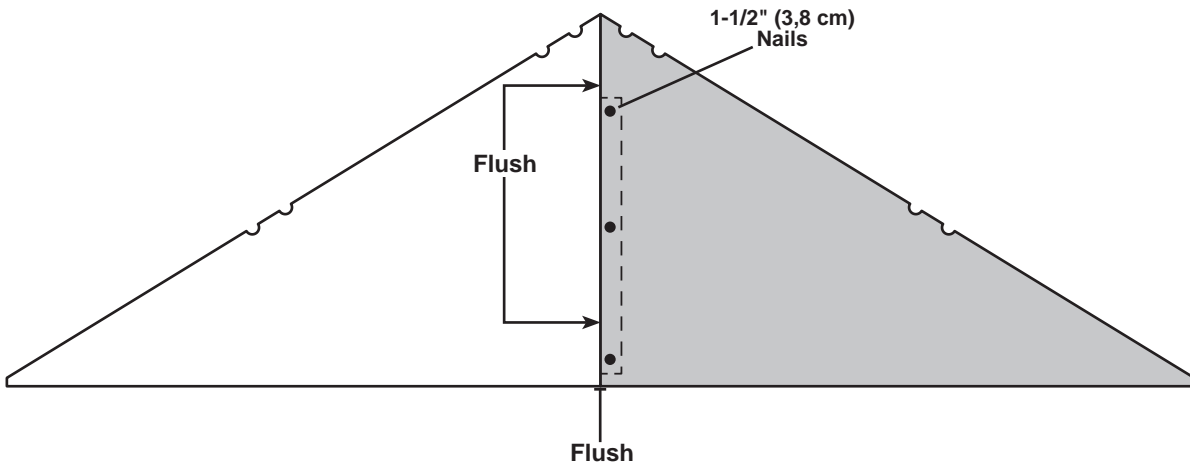

You have finished assembling your back wall gable.

FRONT GABLE

PARTS REQUIRED:

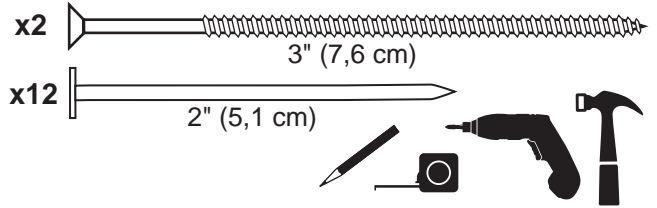
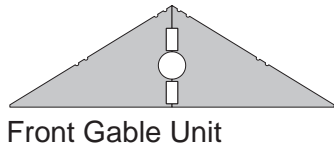

✓ BEGIN



1 Center front gable unit on front wall gable nailer. Secure gable unit with 2" nails evenly spaced.

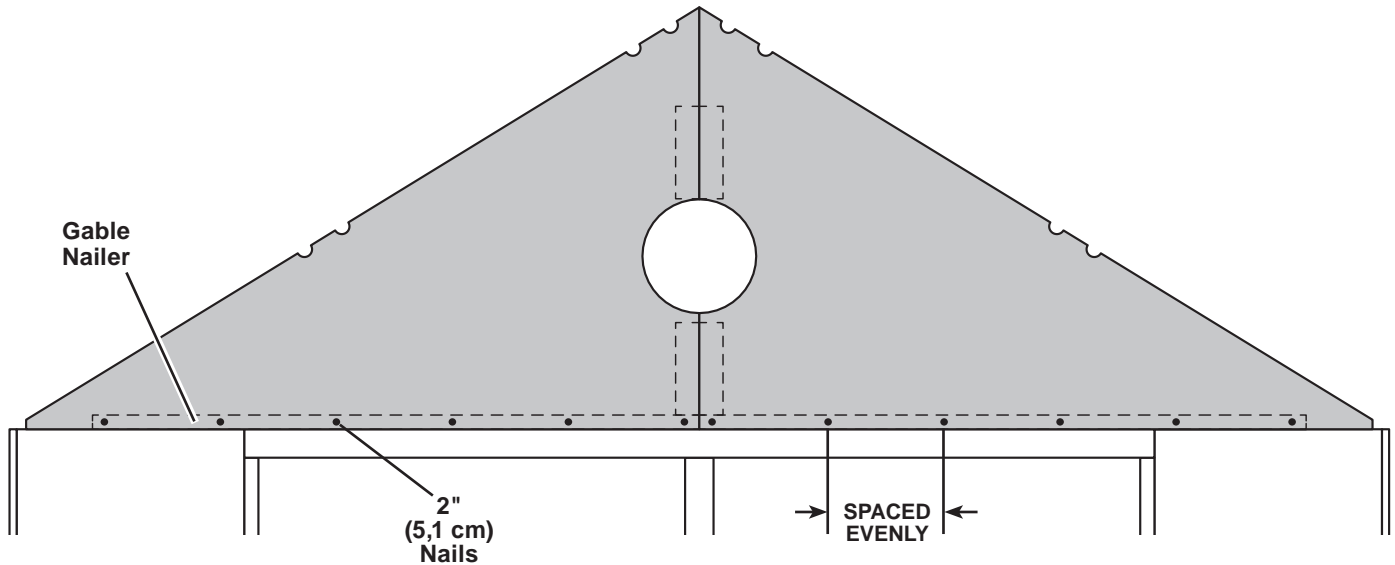

2 Working inside, secure gable unit with 3" screws toe-screwed into nailer and top plate at an angle.

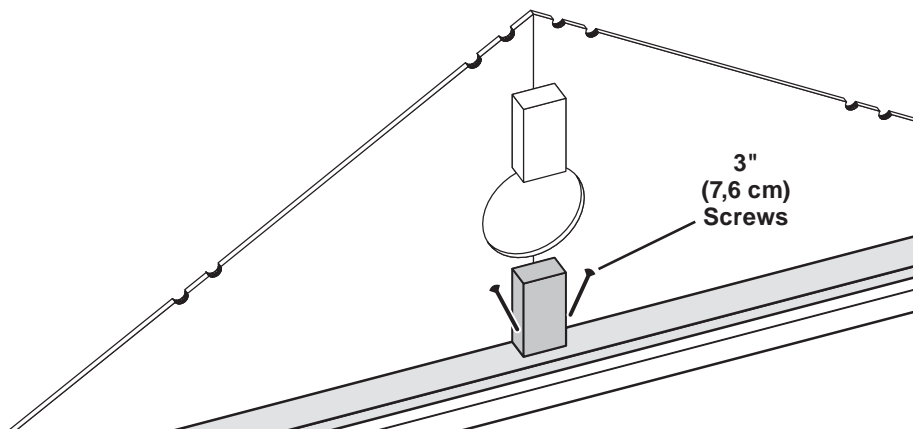

Your front gable is now installed.

BACK GABLE

PARTS REQUIRED:

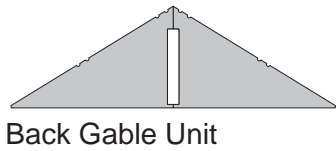

x2 3" (7,6 cm)

x12 2" (5,1 cm)

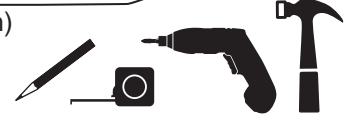

✓ BEGIN



1 Center back gable unit on back wall gable nailer. Secure gable unit with 2" nails evenly spaced.

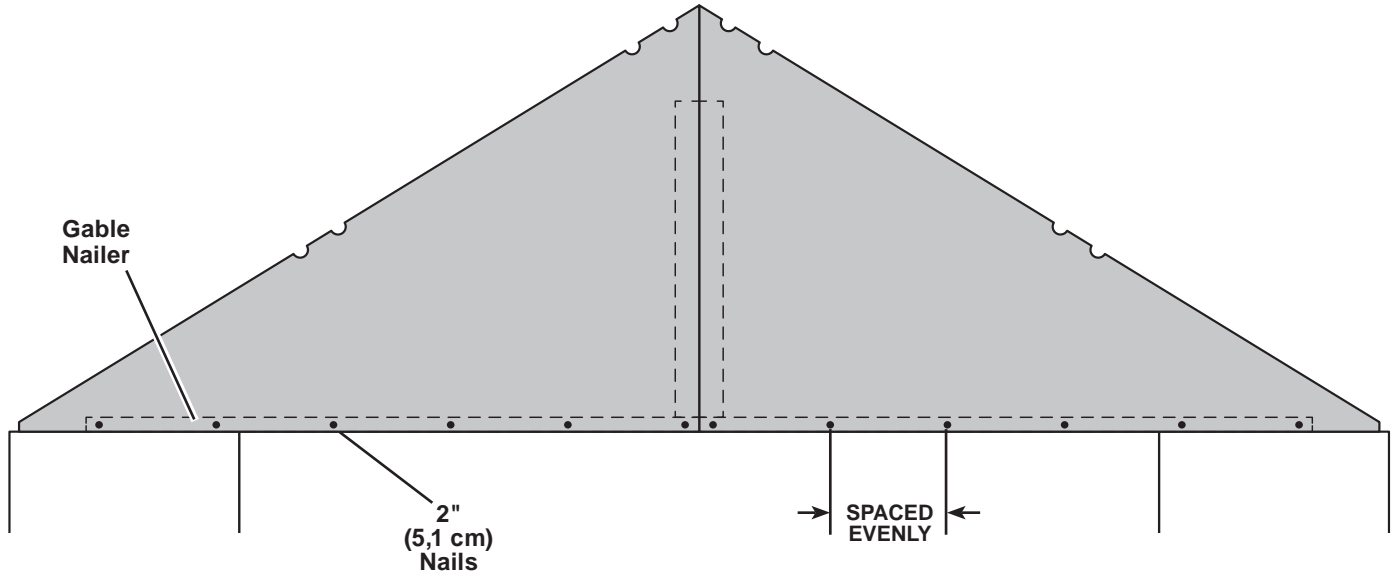

2 Working inside, secure gable unit with 3" screws toe-screwed into nailer and top plate at an angle.

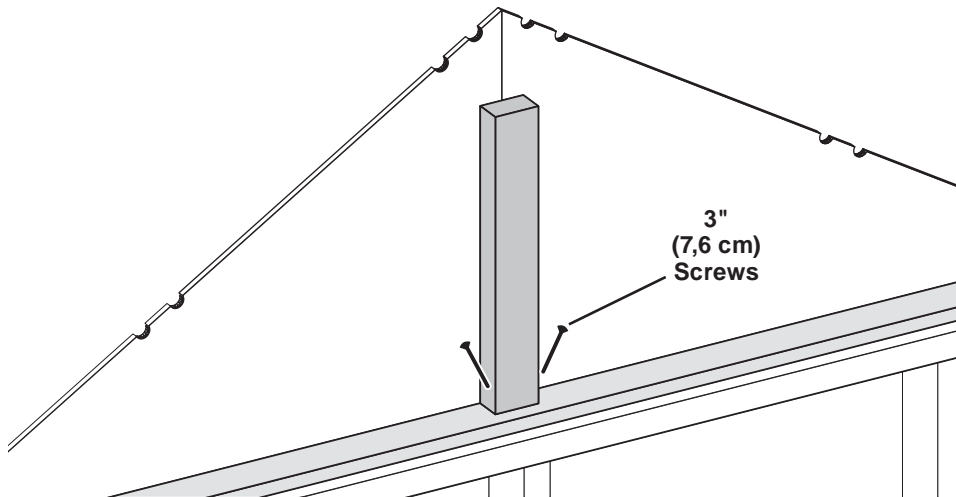

Your back gable is now installed.

SOFFIT TRIM

PARTS REQUIRED:

x4 **JEB**
2 x 3-3/16" x 49-1/2" (5,1 x 8,1 x 125,7 cm)



x16

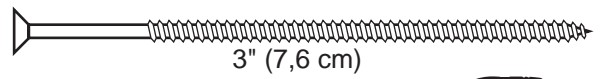

3" (7,6 cm)



✓ BEGIN

- 1 Install soffit trim **JEB** as shown (**Fig. A**). Flush **JEB** along top of side wall panels. Secure using 3" screws into top plate (**Fig. B**).

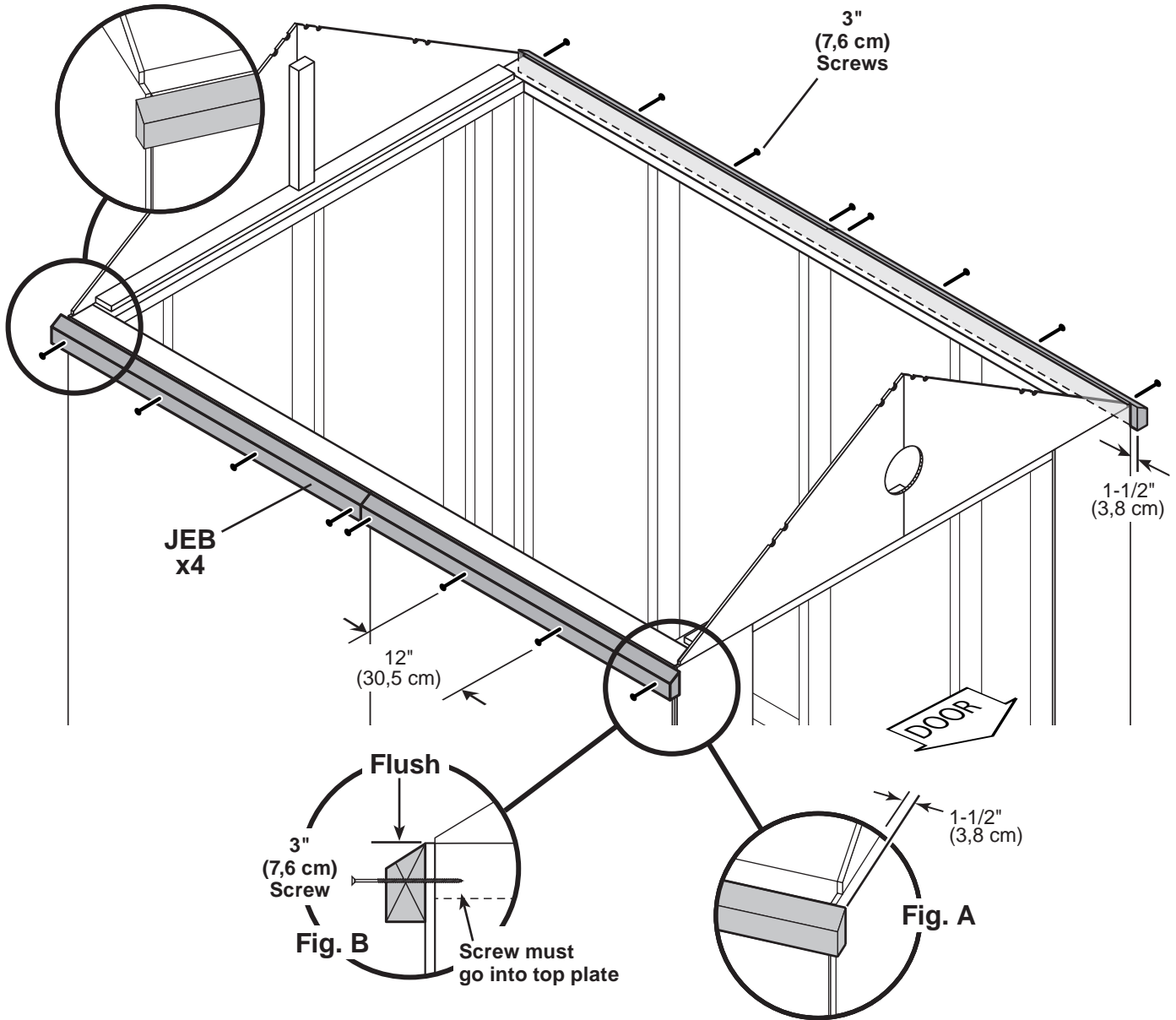

Your soffit trim is now installed.

FRONT GABLE TRIM FILLER

PARTS REQUIRED:

x2 **IUA**
2 x 3 x 42-5/8" (5,1 x 7,6 x 108,3 cm)



x10

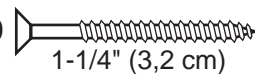

1-1/4" (3,2 cm)

✓ **BEGIN**

- 1 Working from inside of gable, secure trim fillers **IUA** using 1-1/4" screws spaced evenly as shown.

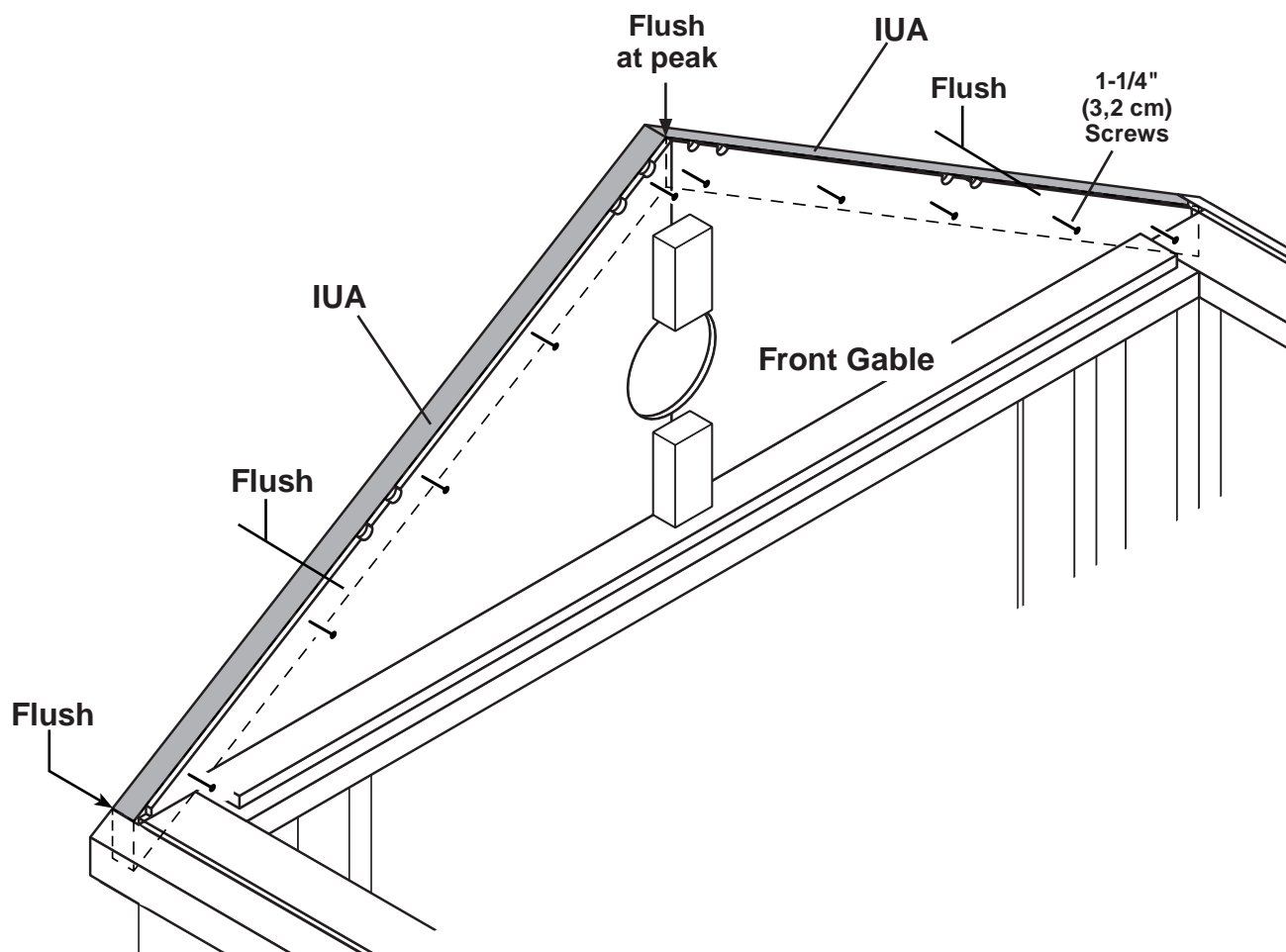

FINISH

Your front gable trim filler is now installed.

BACK GABLE TRIM FILLER

PARTS REQUIRED:

x2 **DTA**
1 x 3 x 42-5/8" (2,5 x 7,6 x 108,3 cm)



x10 
1" (2,5 cm)

✓ **BEGIN**

1 Working from inside of gable, secure trim fillers **DTA** using 1" screws spaced evenly as shown.

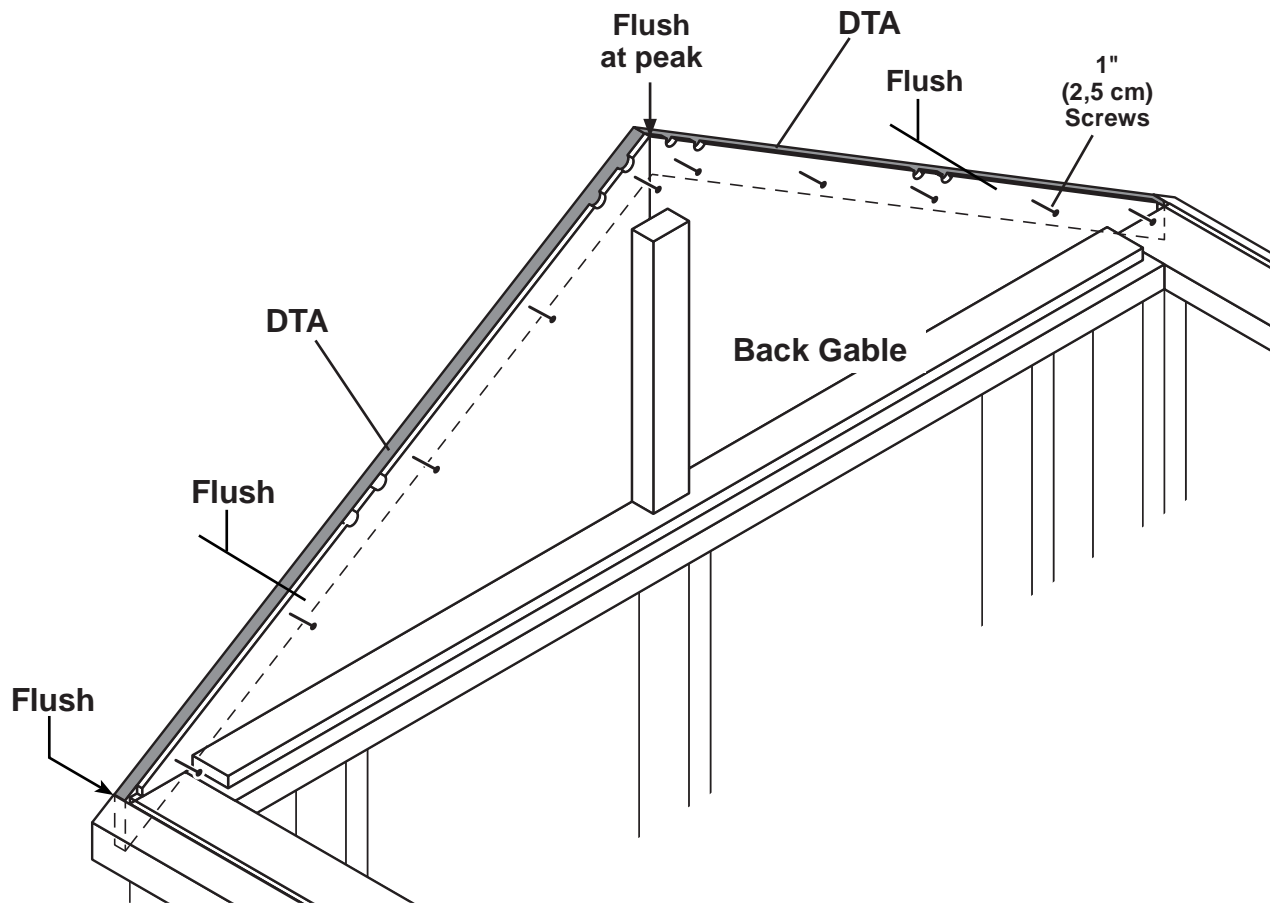

Your back gable trim filler is now installed.

ROOF PURLINS

PARTS REQUIRED:

x4 TP
2 x 4 x 96" (5,1 x 10,2 x 243,8 cm)

x8
3-1/2" (8,9 cm)

x8
3" (7,6 cm)

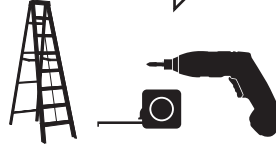

✓ BEGIN

- 1 Align TP using notches in the gable panel for position (**Fig. A**).
- 2 Secure TP from outside using 3" screws at back gable and using 3-1/2" screws at front gable.

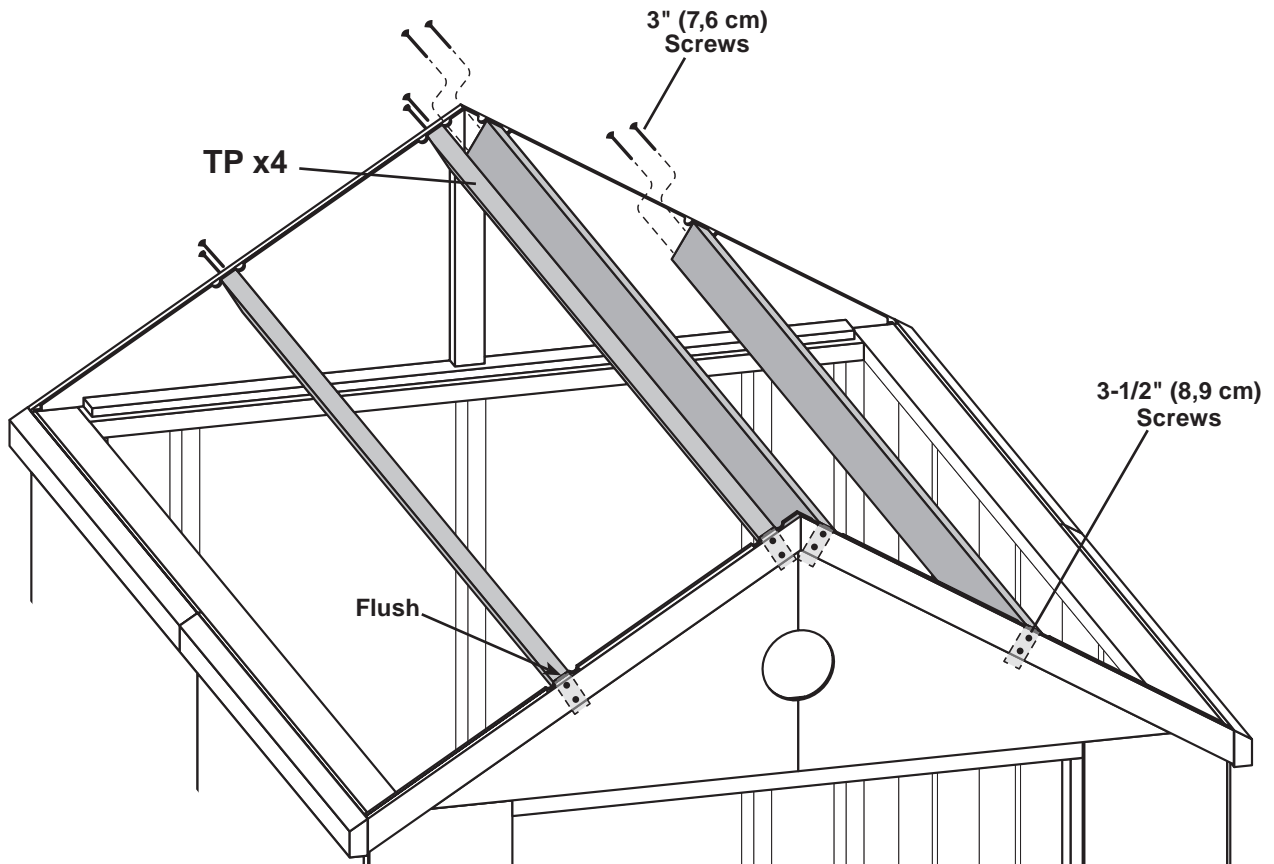
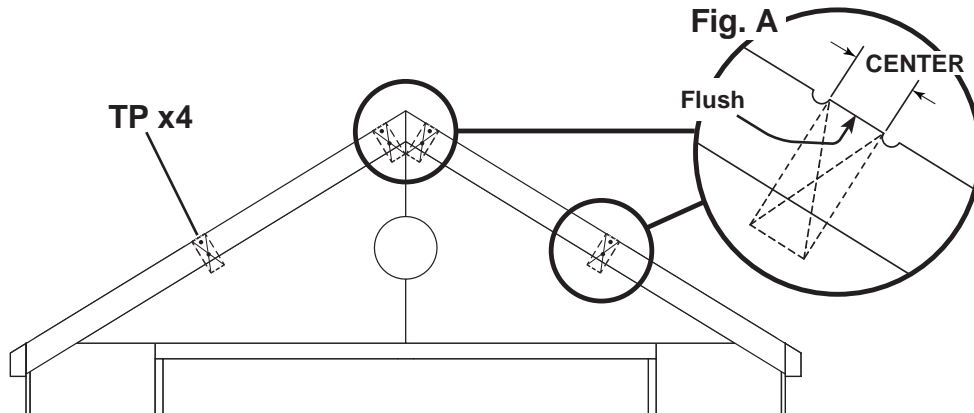

Your roof joists are now installed.

CORNER TRIM

PARTS REQUIRED:

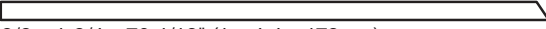
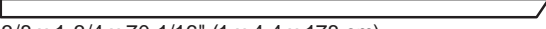
- x4 
3/8 x 1-3/4 x 68-13/16" (1 x 4,4 x 174,8 cm)
- x2 
3/8 x 1-3/4 x 70-1/16" (1 x 4,4 x 178 cm)
- x2 
3/8 x 1-3/4 x 70-1/16" (1 x 4,4 x 178 cm)

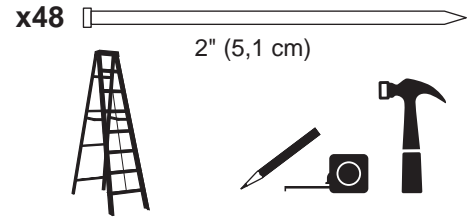

✓ BEGIN

1 Attach corner trim as shown using 2" finish nails.

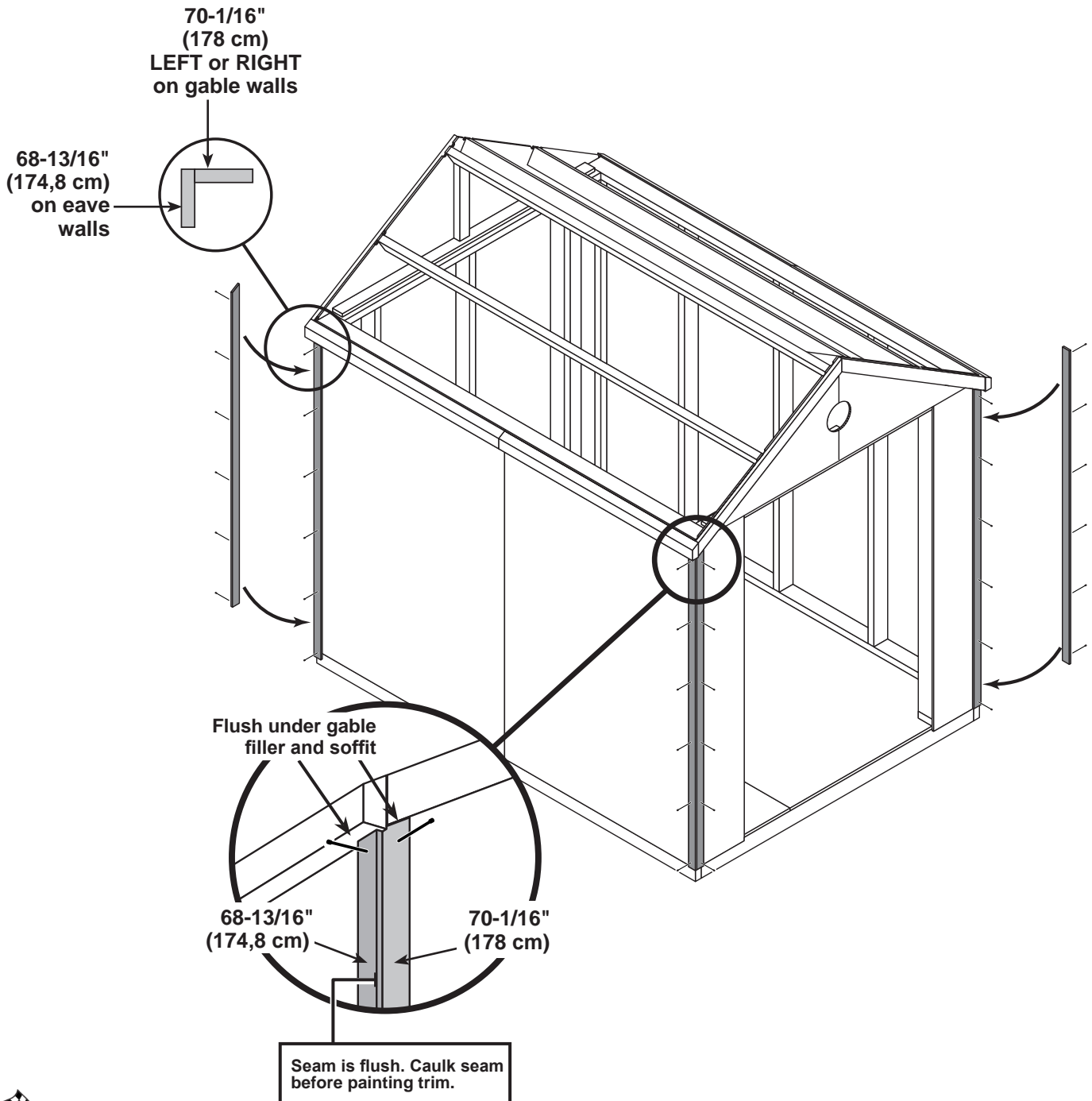

Your corner trim is now installed.

HORIZONTAL GABLE TRIM

PARTS REQUIRED:

x2 **KFC**
19/32" x 2-1/2" x 63-13/16" (1,5 x 6,3 x 162,1 cm)

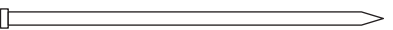
x14 
2" (5,1 cm)



✓ **BEGIN**

- 1 Attach horizontal gable trim **KFC** to front and back gable as shown.
Nail into gable nailer using 2" finish nails spaced evenly.

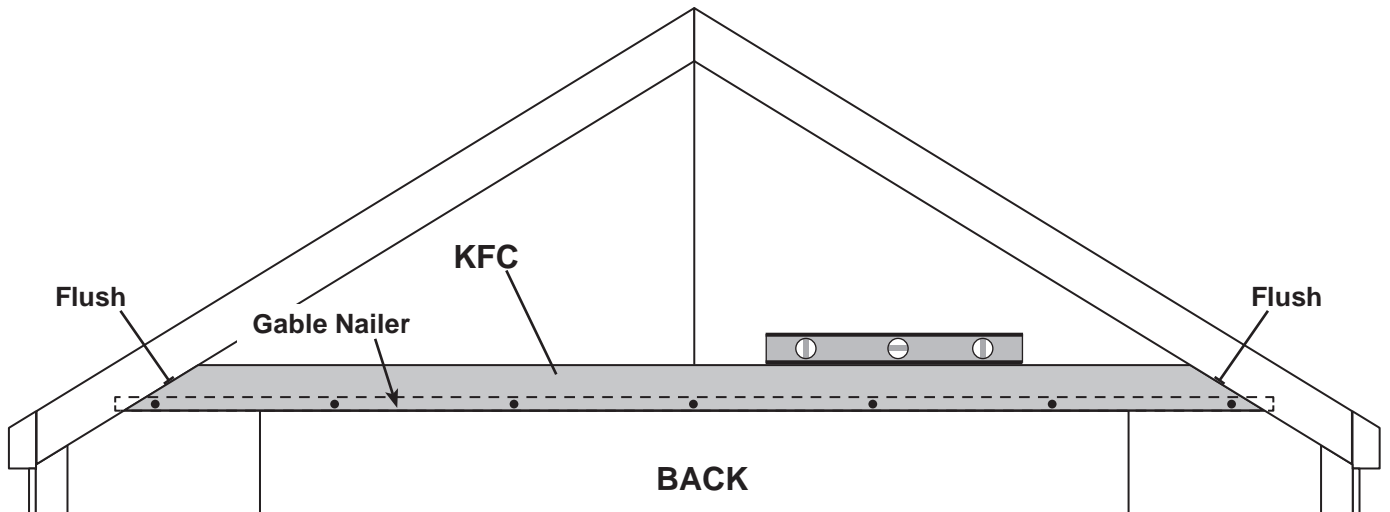
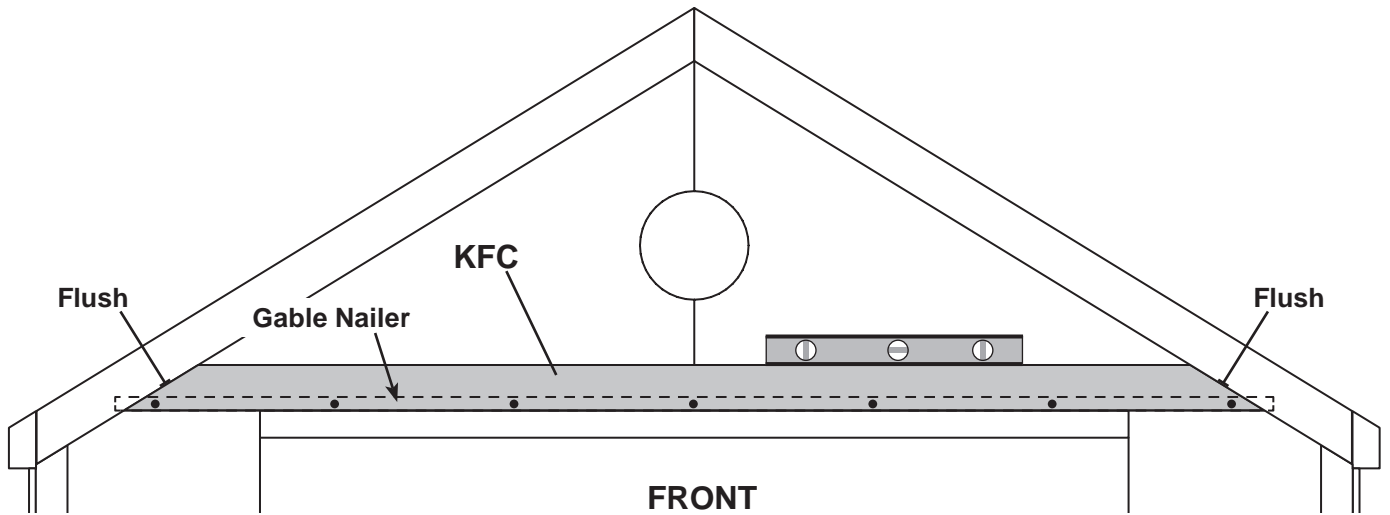

Your horizontal gable trim is now installed.

FRONT GABLE TRIM

PARTS REQUIRED:

- x2 **WCR**
19/32 x 3-1/2 x 47" (1,5 x 8,9 x 119,4 cm)
- x2 **WCL**
19/32 x 3-1/2 x 47" (1,5 x 8,9 x 119,4 cm)



x10

2" (5,1 cm)

✓ **BEGIN**

- 1** Position **WCL** and **WCR** flush with top of front gable panels and filler.
Nail into gable filler and soffit trim using 2" finish nails spaced evenly as shown.

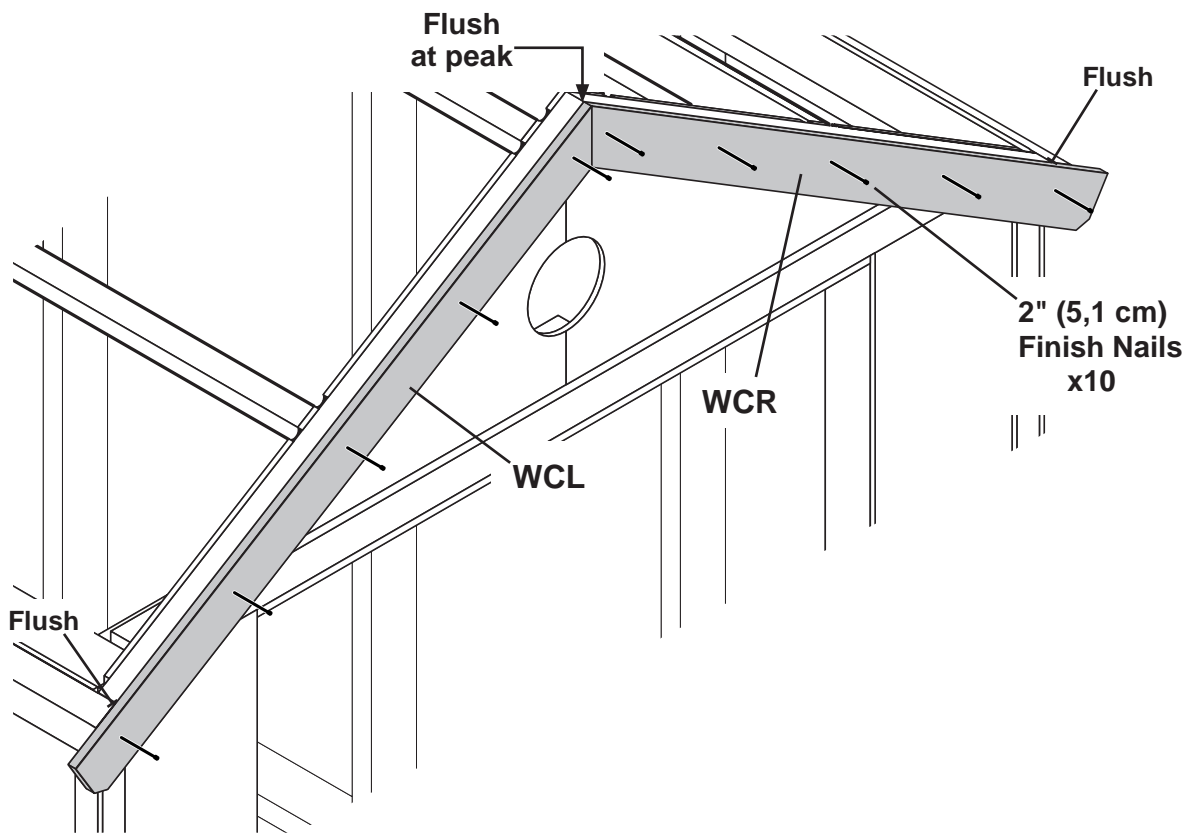

Your front gable trim is now installed.

BACK GABLE TRIM

PARTS REQUIRED:

- x2 **WCR**
19/32 x 3-1/2 x 47" (1,5 x 8,9 x 119,4 cm)
- x2 **WCL**
19/32 x 3-1/2 x 47" (1,5 x 8,9 x 119,4 cm)

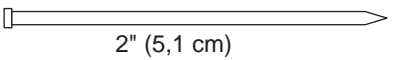

x6  2" (5,1 cm)

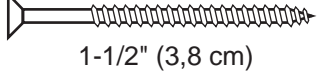
x8  1-1/2" (3,8 cm)

✓ **BEGIN**

1 Position **WCL** and **WCR** flush with top of back gable panel and filler.

Nail into gable filler and soffit trim using 2" finish nails spaced evenly as shown.

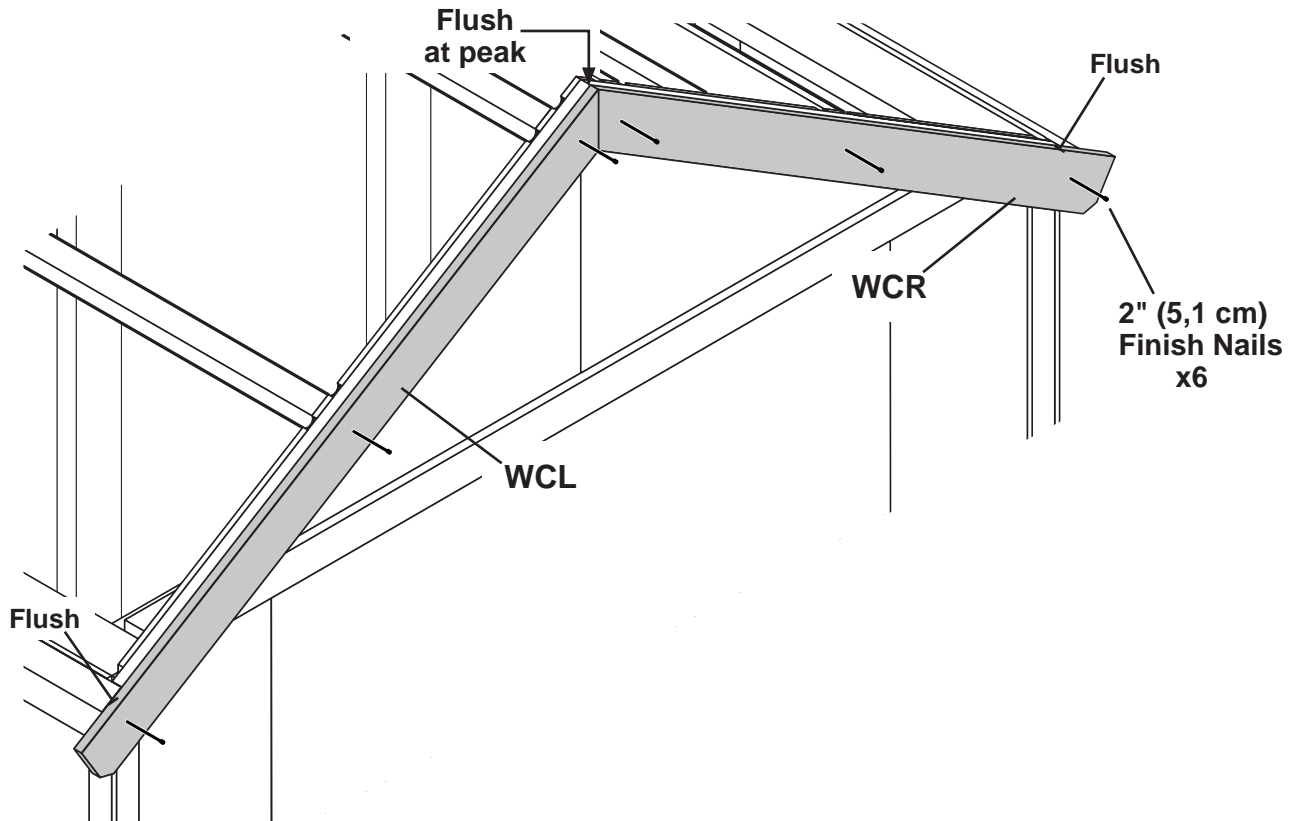

2 Working from inside of shed reinforce trim using 1-1/2" screws (Fig. A).

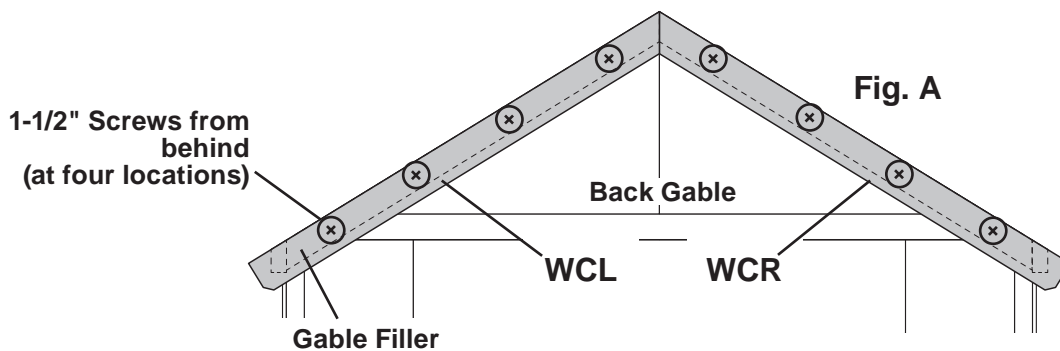

Your back gable trim is now installed.

METAL ROOF PANELS

PARTS REQUIRED:

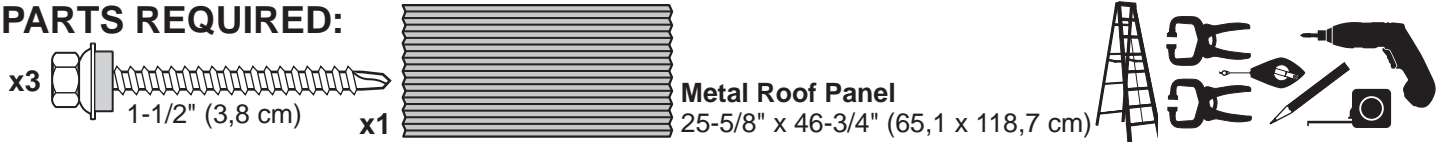

✓ **BEGIN**

- Using (2) clamps, tightly clamp a string or chalkline to front and back gable trim. Position string flush to top corner edge of gable trim (**Fig. A, Fig. B**).

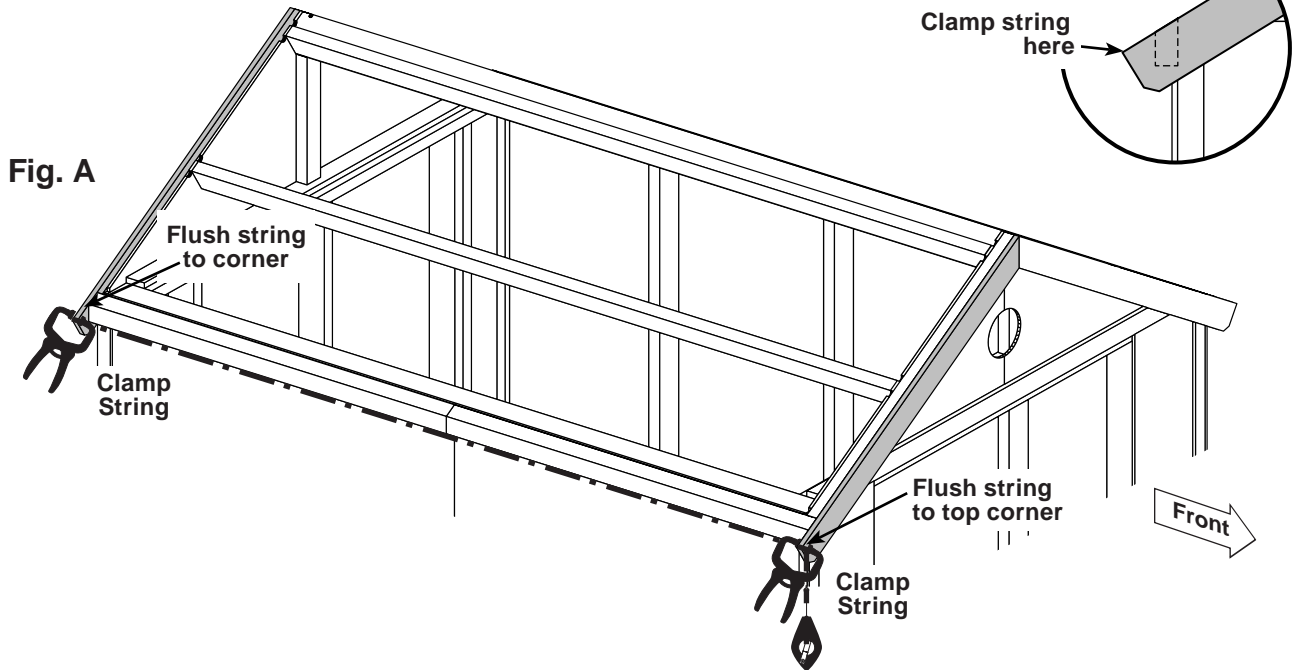

- Mark each center line dimension shown on top of gable trim. Place the first roof panel with front bottom corner centered on the gable trim (**Fig. C**) and bottom edge in line with string. Referencing the center line marks on top of the gable trim, secure panel to soffit trim and purlins using (3) 1-1/2" screws. Install screws in panel valley (**Fig. D**) nearest edge.

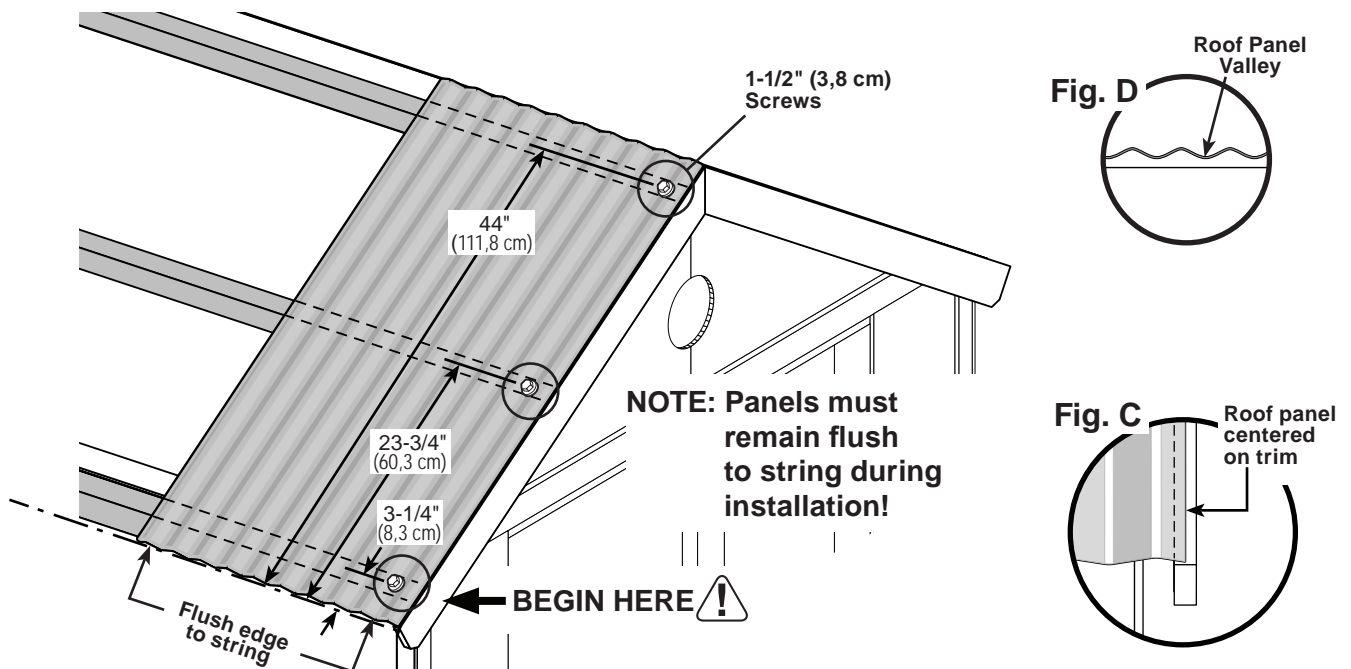

METAL ROOF PANELS

PARTS REQUIRED:

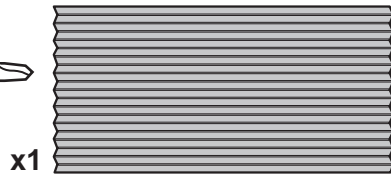
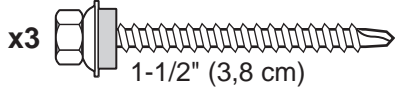

Metal Roof Panel
25-5/8" x 46-3/4" (65,1 x 118,7 cm)

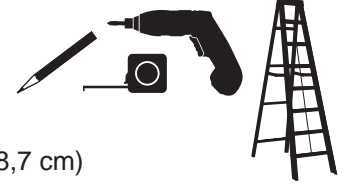

Install roof panel with 3 overlapping contour waves covering the previously installed panel.

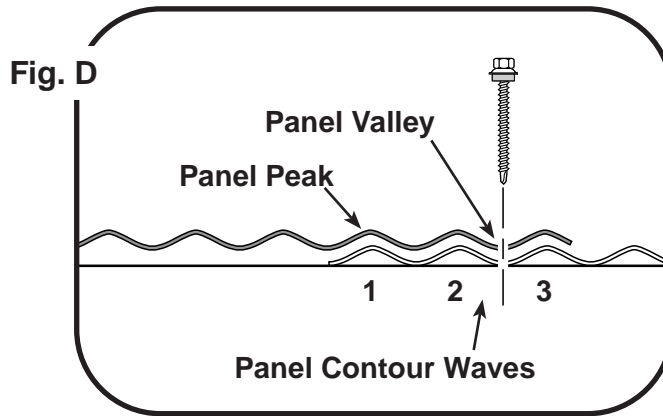

- 3** Position 2nd panel overlapping the first panel by 3 panel contour waves (**Fig. D**) and flush to string.
Secure panel to trim **JEB** and roof joists **TP** using (3) 1-1/2" screws in panel valley nearest edge.

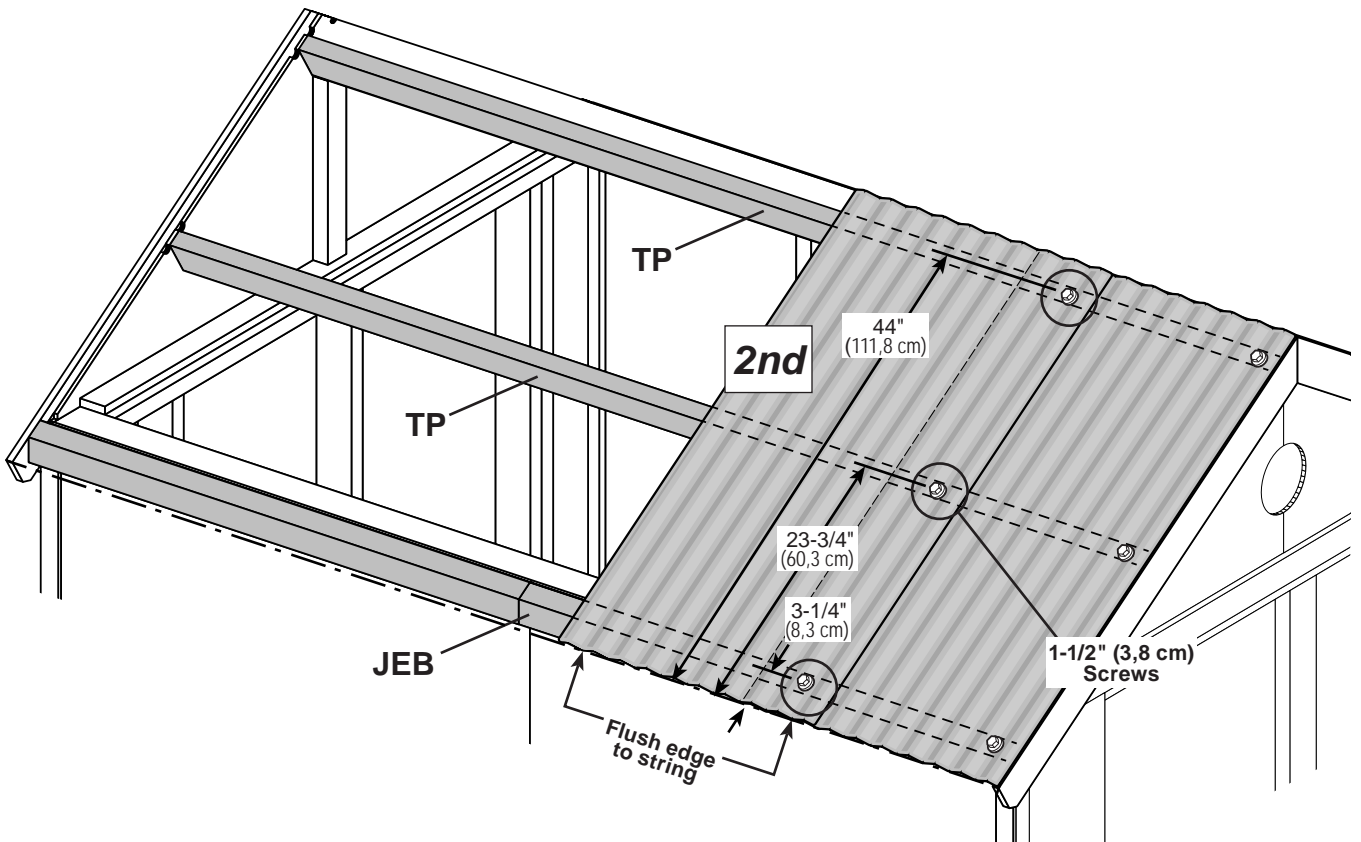

METAL ROOF PANELS

PARTS REQUIRED:

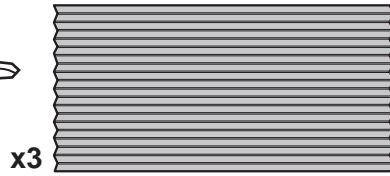
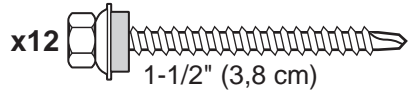

Metal Roof Panel
25-5/8" x 46-3/4" (65,1 x 118,7 cm)

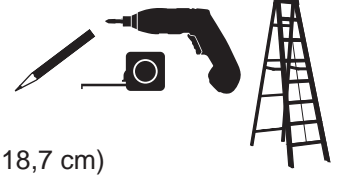

- 4** Install three more metal roof panels as in STEP - 3, overlapping all panels by 3 panel contour waves. Install (3) screws in each panel valley nearest edge. Install (6) screws in last panel, as shown.

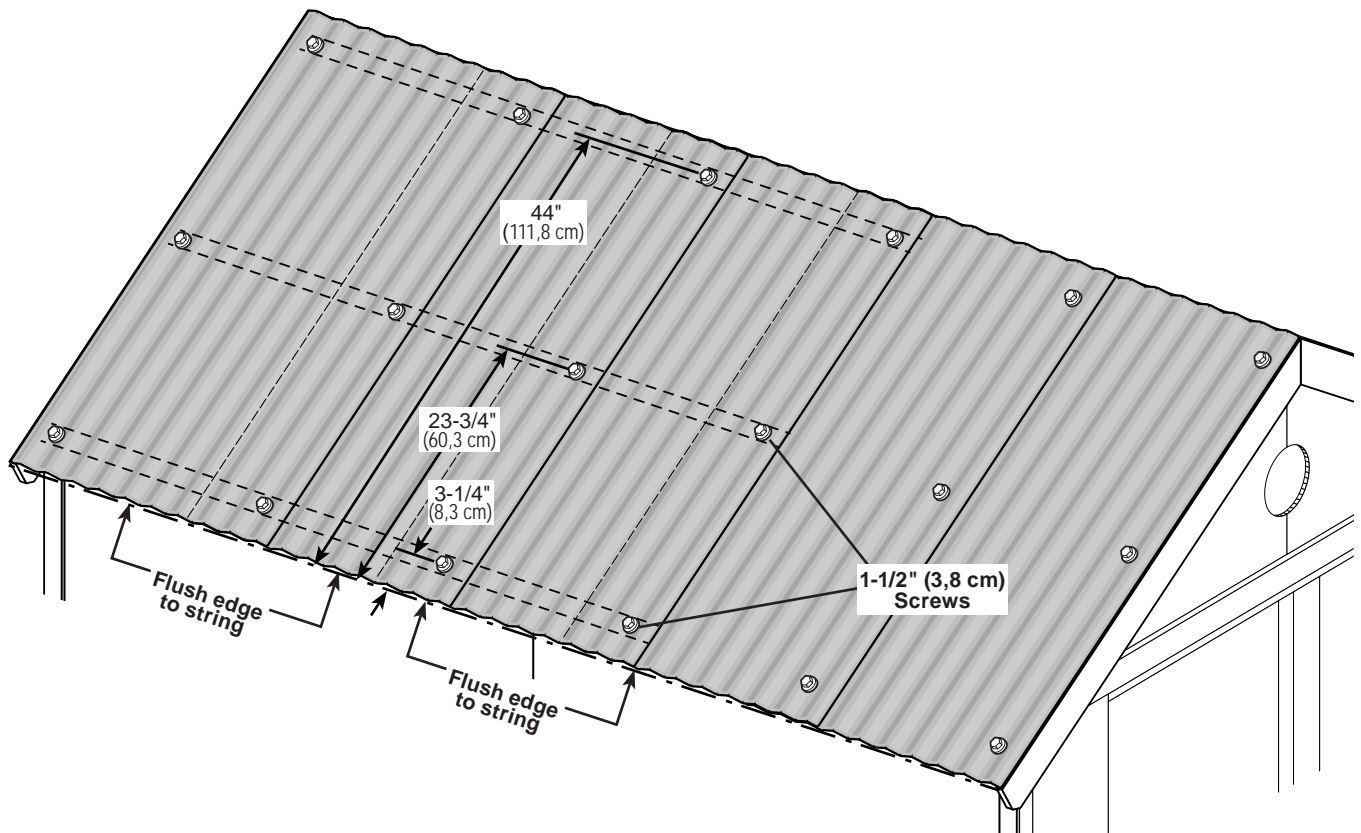

METAL ROOF PANELS

PARTS REQUIRED:

x10  Closure Strip 24" (61 cm)

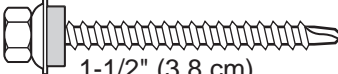
x18  1-1/2" (3,8 cm)



- 5 Temporarily back-out the lower (6) screws from metal panels and eave trim (Fig. F). Beginning at the front panel, tuck (5) foam enclosures in between roof panels and eave trim. The 4th and 5th foam enclosure will overlap at the back panel. Reinstall screws.

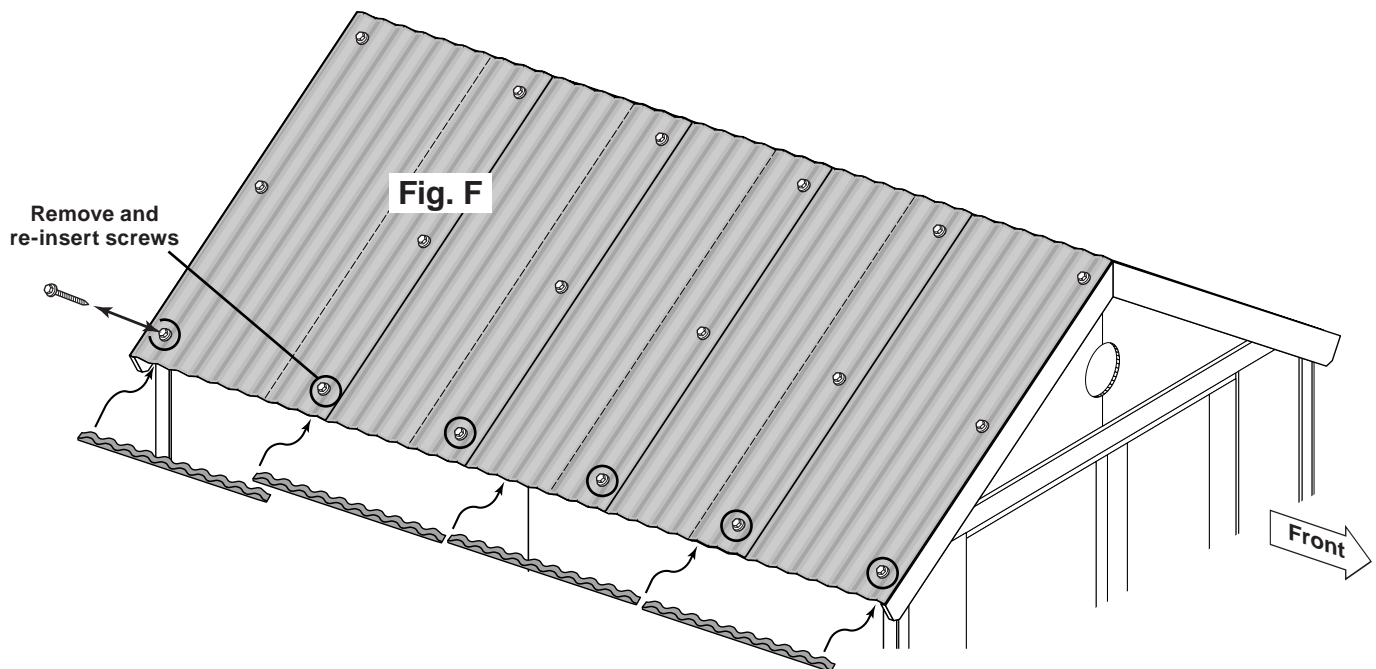

- 6 Install (5) roof panels on opposite side of roof following STEPS 1 - 5, beginning at the front gable.

METAL ROOF PANELS - SCREW PATTERN

PARTS REQUIRED:

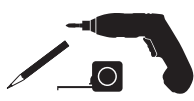

x60

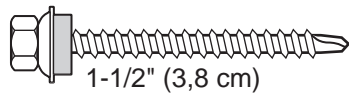

x16

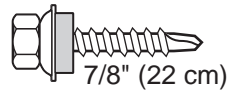

✓ BEGIN

1 Measure and mark screw type and locations shown in this view. Use this pattern for all panels.

X indicates 7/8" Screws (Peak edge of each panel)

O indicates 1-1/2" Screws

● screws already installed

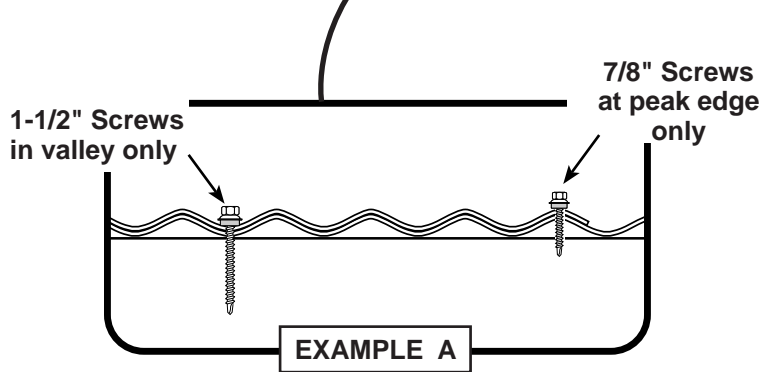
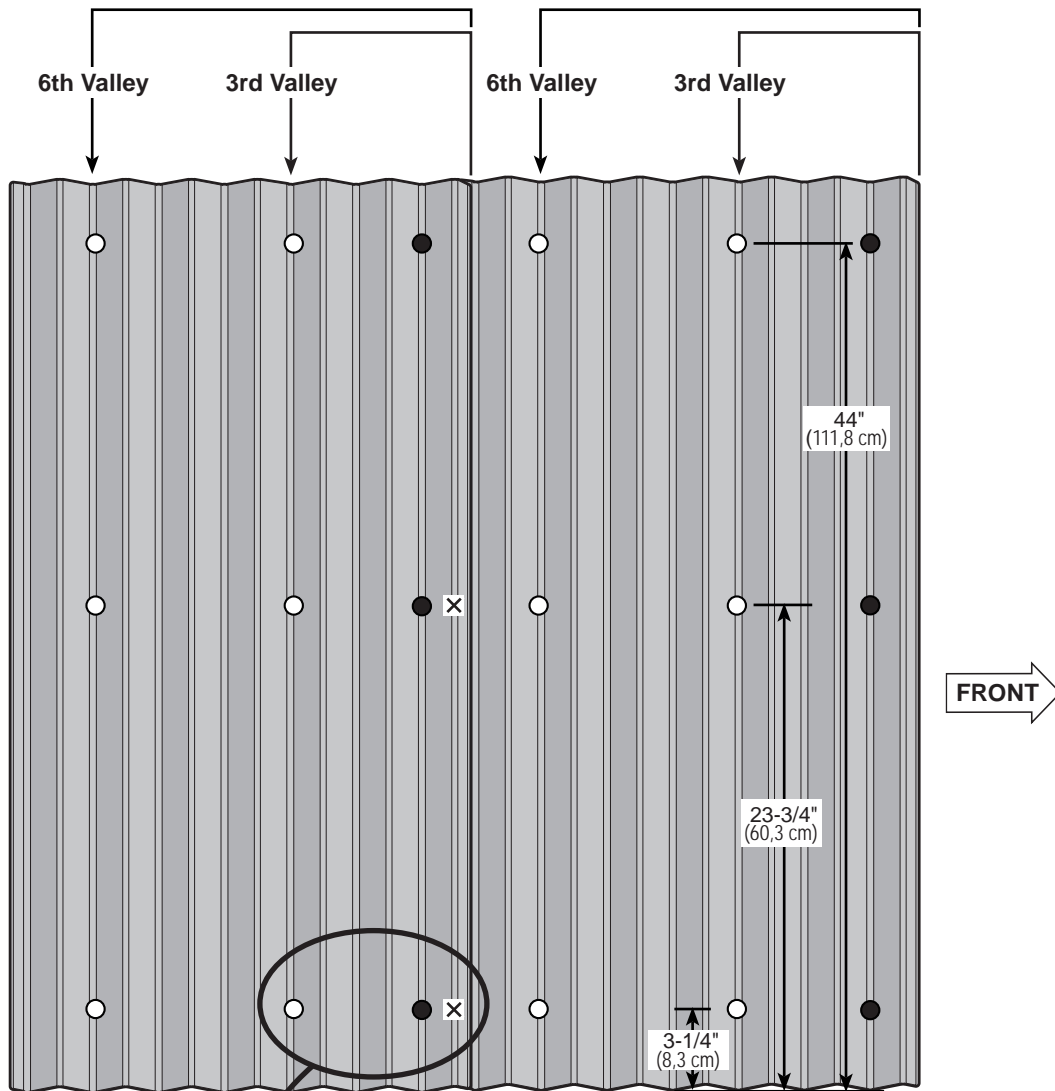

NOTE:
Only two lower 7/8" screws per panel at this time.

METAL RIDGE CAP

PARTS REQUIRED:

x2 

Ridge Cap

4" x 4" x 54" (10,2 x 10,2 x 137,2 cm)

x10  Closure Strip 24" (61 cm)

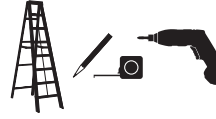

x12  7/8" (2,2 cm)

✓ BEGIN

- 1 Install 1st ridge cap flush to front of roof panels across the peak of the roof. Foam enclosures go in-between the metal roof and the bottom edge of the ridge cap as shown. Secure using (4) 7/8" screws 1/2" from edge of ridge cap (**Fig A**). Install screws in second peak from end of ridge cap (**Fig B**).

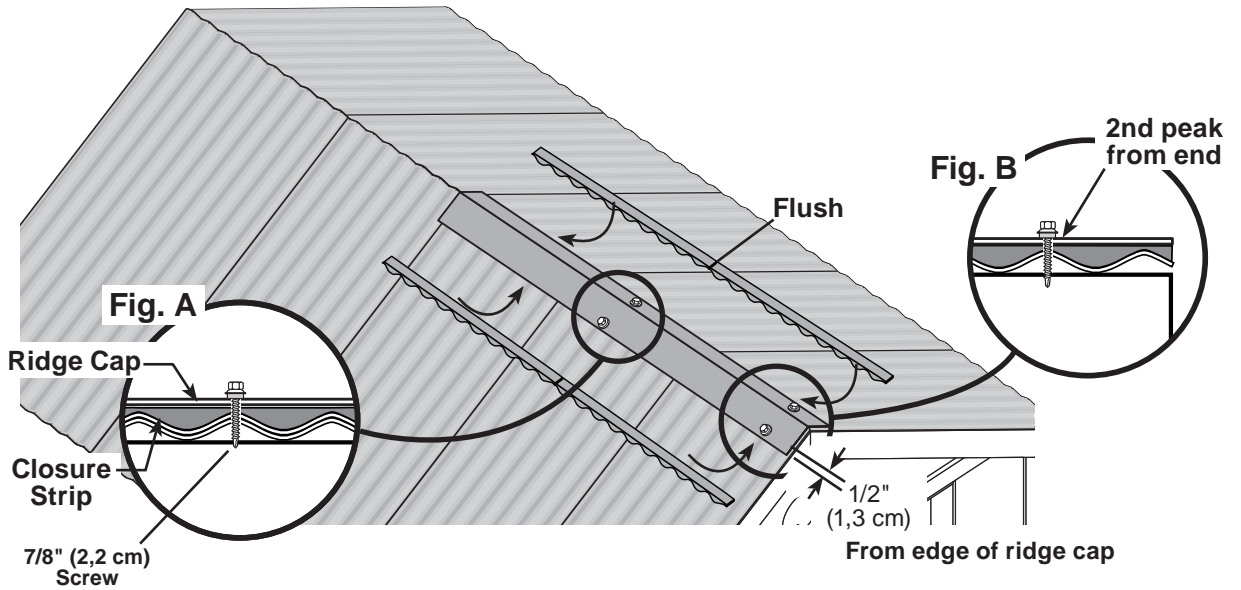

- 2 Install 2nd ridge cap flush to back of roof panels, across the peak of the roof and overlapping the installed ridge cap. Install foam enclosures as in STEP - 1 using (8) 7/8" screws. The last foam enclosure on each end will overlap the previous enclosures. Install screws in second peak from end of ridge cap (**Fig B**).

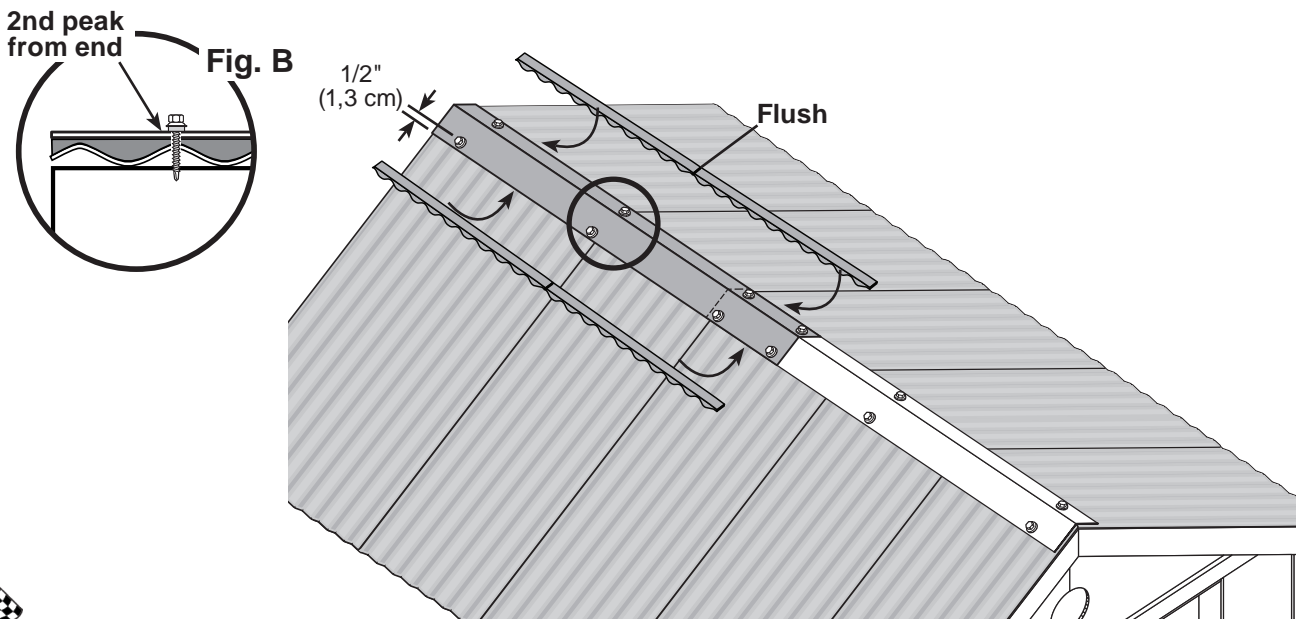

Your ridge cap are now installed.

METAL DRIP EDGE

PARTS REQUIRED:

x2 Metal Drip Edge
3" x 95-1/2" (7,0 x 217,2 cm)

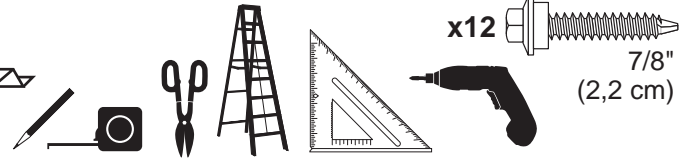

✓ BEGIN

- 1 Measure and mark center of drip edge.
- 2 Using a framing square scribe a 31.5° line from your center point, cut the line.

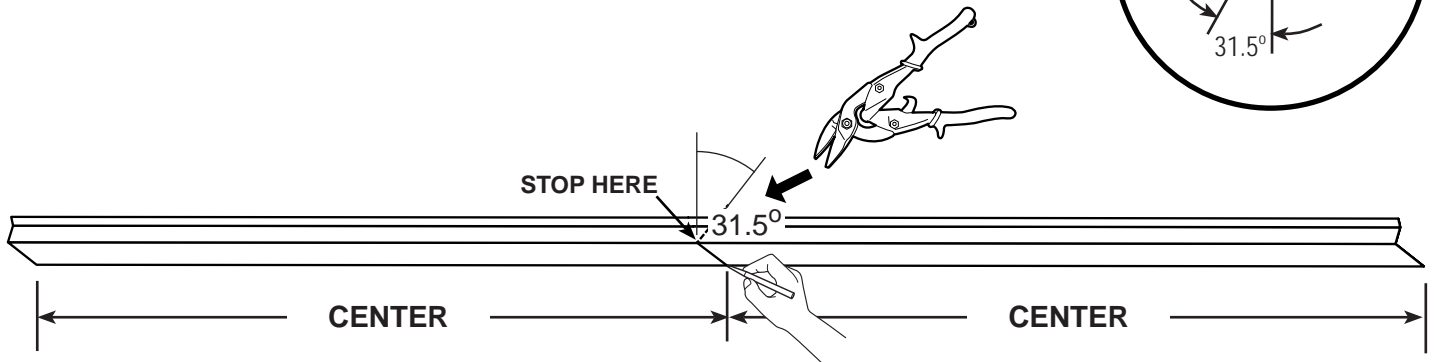

- 3 Place drip edge centered at peak of gable. Fold down at center cut over peak of gable. Position vertical edge of drip edge flush to gable trim. Secure using (3) 7/8" screws per side and as shown as shown in Fig. A. Repeat STEPS 1 - 4 to install drip edge at opposite gable.

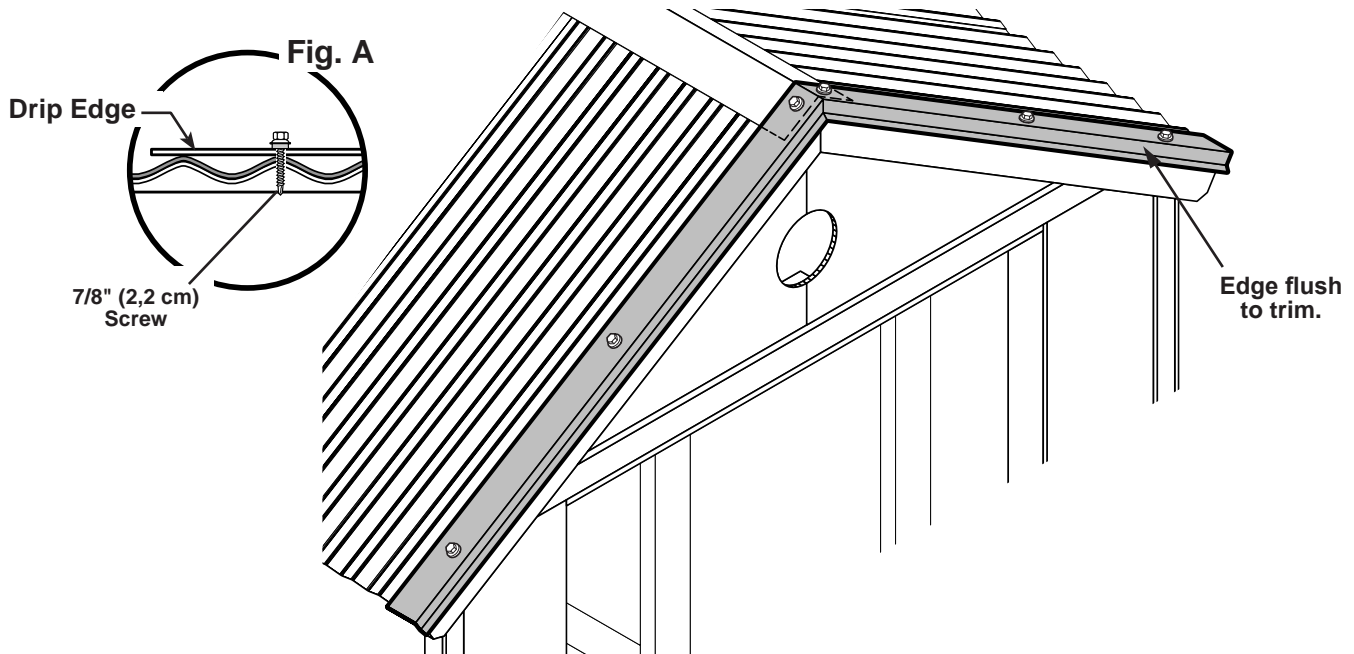



DOORS

PARTS REQUIRED:

x1 **OO**
Door Stiffener 69" (175,3 cm)

x1 **GAA**
1 x 3 x 5" (2,5 x 7,6 x 12,7 cm)

x4  3" (7,6 cm)

x2  1-1/4" (3,2 cm)

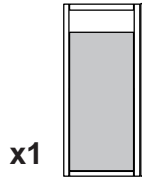
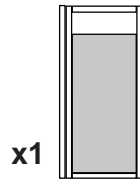

Left Door Assembled

Right Door Assembled

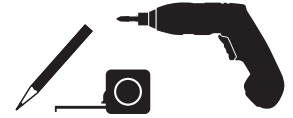

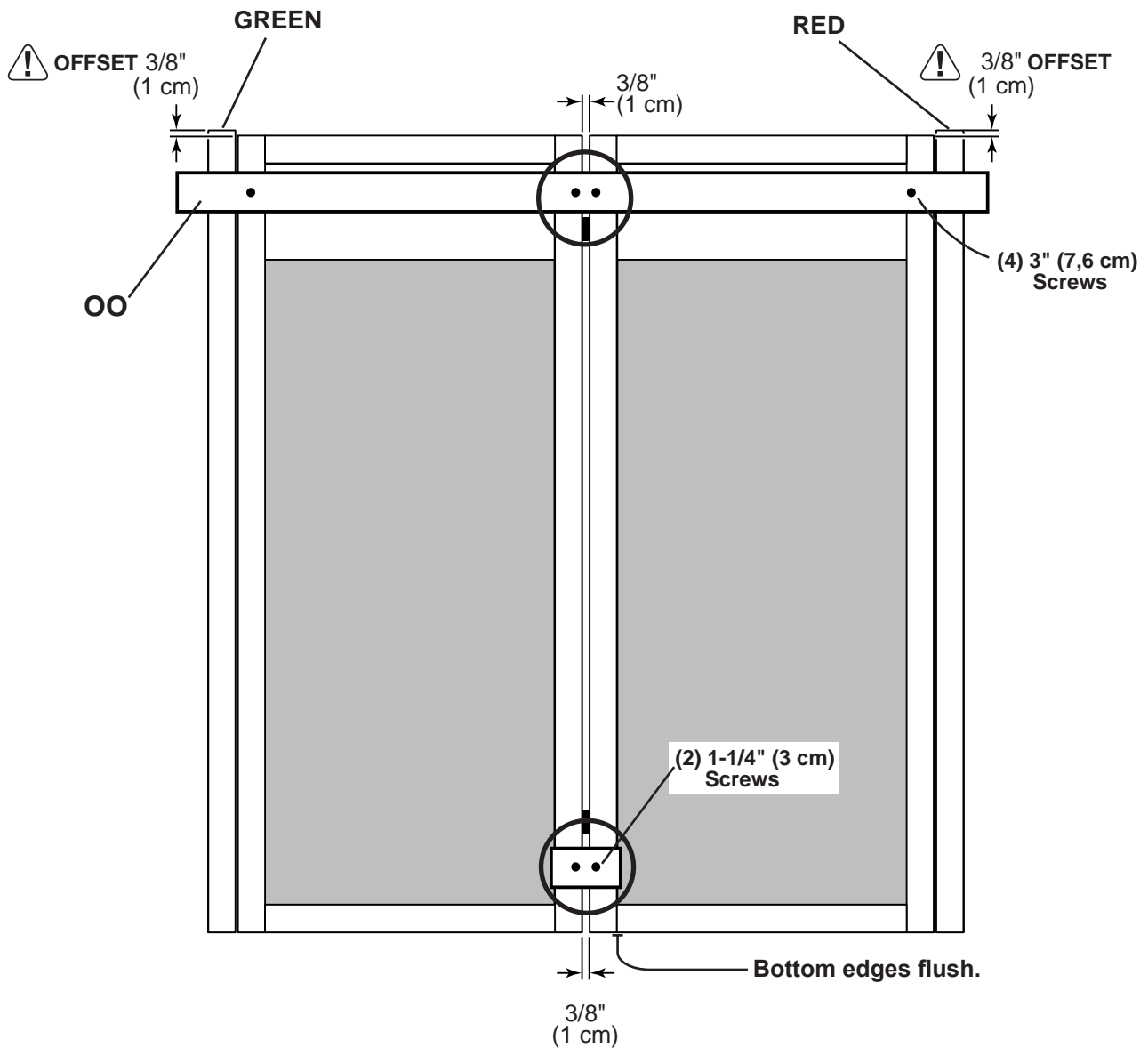

- 1 Orient parts as shown on flat surface.  **3/8" offset is to top.**
Look for red (right) and green (left) on hinge board.
- 2 Attach temporary support **OO** using (4) 3" screws in middle and at ends as shown.
- 3 Attach temporary support **GAA** using (2) 1-1/4" screws as shown.





DOORS

PARTS REQUIRED:

x1 
Door Stiffener 69" (175,3 cm)

x12 
3" (7,6 cm) 

- 4 Attach temporary support  as a ledger board flush under wall panels for doors to rest on. Measure down 72" from over-door trim and secure  using (2) 3" screws (**Fig. A**).

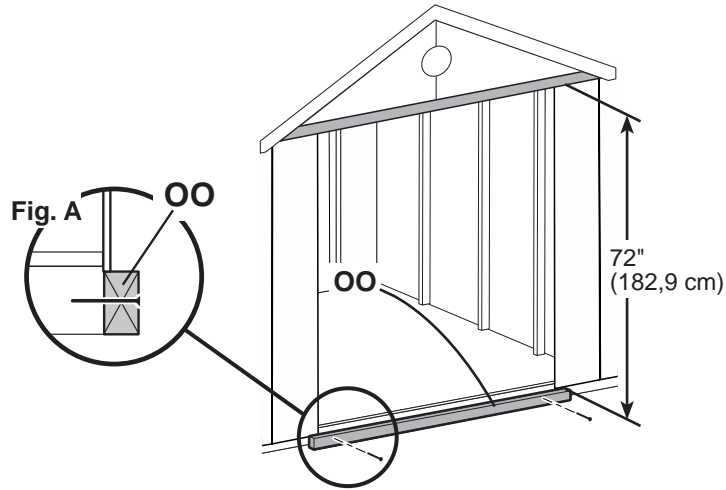

- 5 Center doors on panel seam as shown (**Fig. B**). 
Screw hinge boards into wall supports and floor using ten 3" screws as shown (**Fig. C**).

- 6 Remove temporary supports and check that the doors open properly.

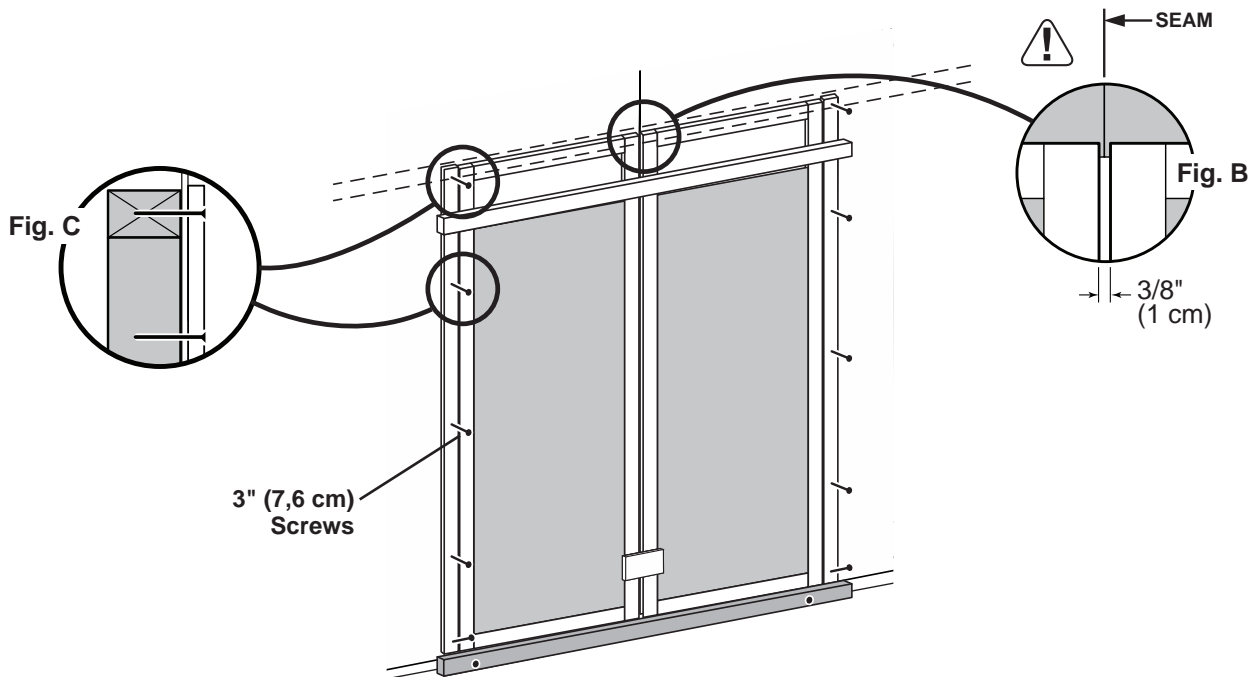

Your doors are now installed.

DOOR TRIM

PARTS REQUIRED:

x4 **EGB**

19/32 x 2-1/2 x 18-5/8" (1,5 x 6,3 x 47,3 cm)

x8  3/4" (1,9 cm)
Bagged separately / special coating

x1 
48" Metal Threshold

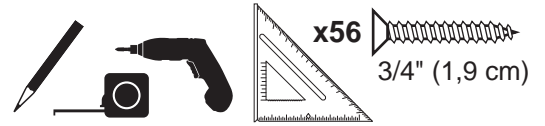

BEGIN

1 Install (4) horizontal door rails **EGB** as shown.
Secure using (4) 3/4" screws from behind.

2 Reinforce door trim from inside using 3/4" screws as shown (**Fig. A**, **Fig. B**).

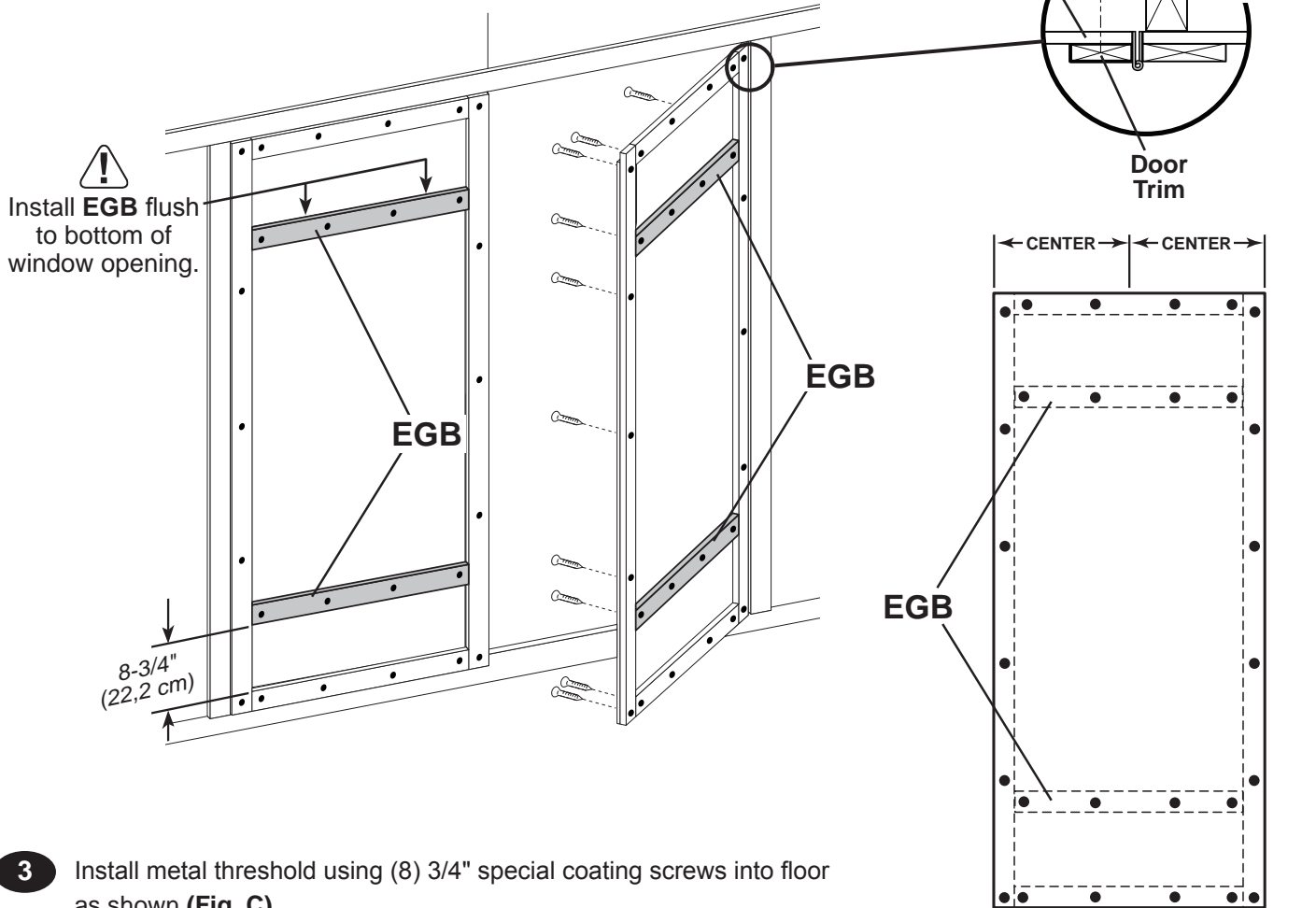

3 Install metal threshold using (8) 3/4" special coating screws into floor as shown (**Fig. C**).

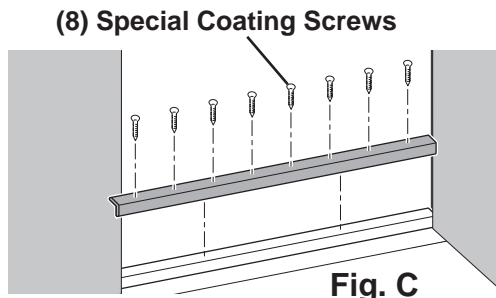

You have finished securing your door, door trim and installing your threshold.

DOOR TRANSOM WINDOWS

PARTS REQUIRED:

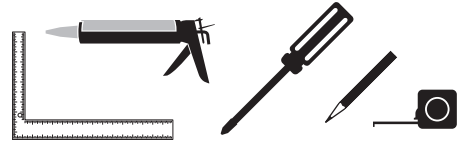
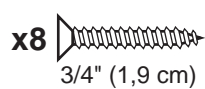
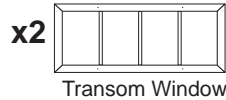

✓ BEGIN

- 1 Apply high quality exterior-grade caulk behind frame near edge before installing to seal window.

You must caulk completely around window frame and all exposed door panel edges and trim to validate your warranty. Use a paintable exterior rated caulk.

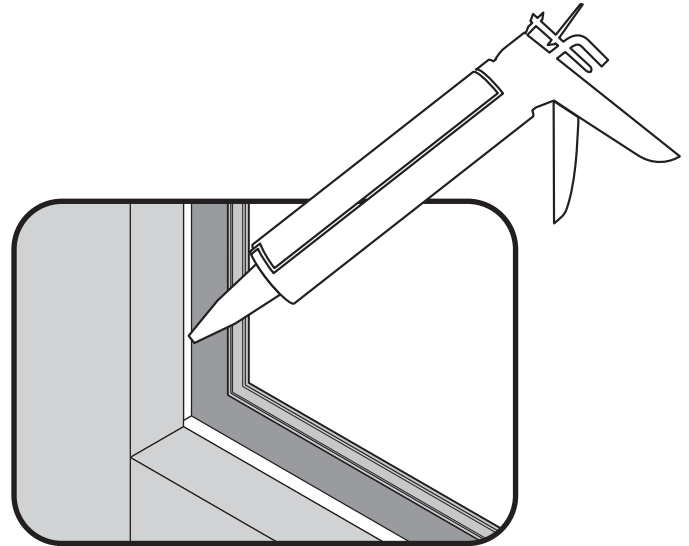

FRONT SIDE VIEW

- 2 From back side of door, measure 11-13/16" from inside edge of door. Mark center of window opening on door.

Position window in opening flush to bottom of window opening. Center window on mark.

Use four screws to secure each window.

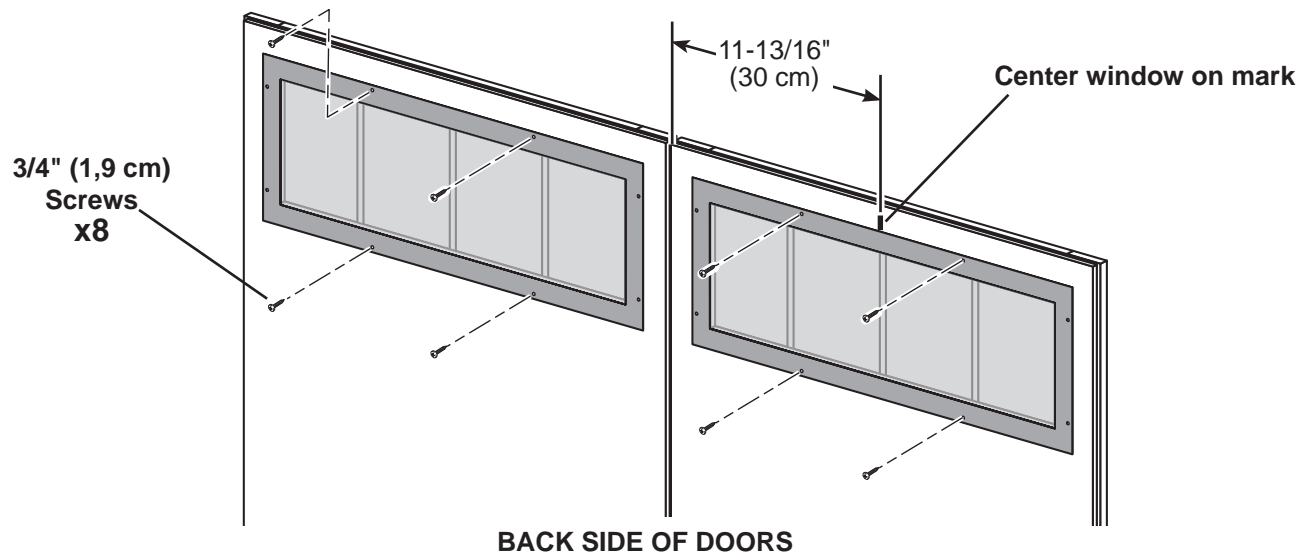

BACK SIDE OF DOORS



Your transom windows are installed.

DOOR STIFFENERS

PARTS REQUIRED:

x2 **OO**
Door Stiffener 69" (175,3 cm)

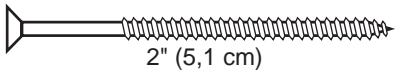
x12  2" (5,1 cm)

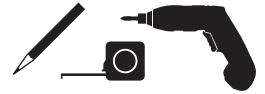

✓ BEGIN

- 1 Center **OO** vertically on the left door in the door opening flush with the edge of door (**Fig. A**).
- 2 Secure using (7) 3" screws through outside trim into **OO** (**Fig. B**)
- 3 Repeat STEPS 1 - 2 to install **OO** on right door.

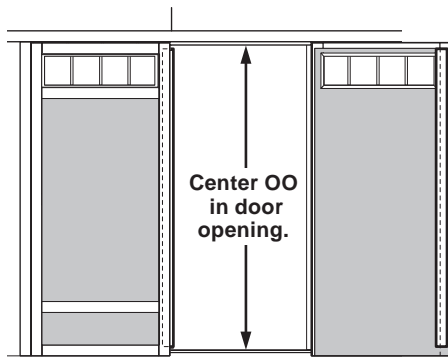
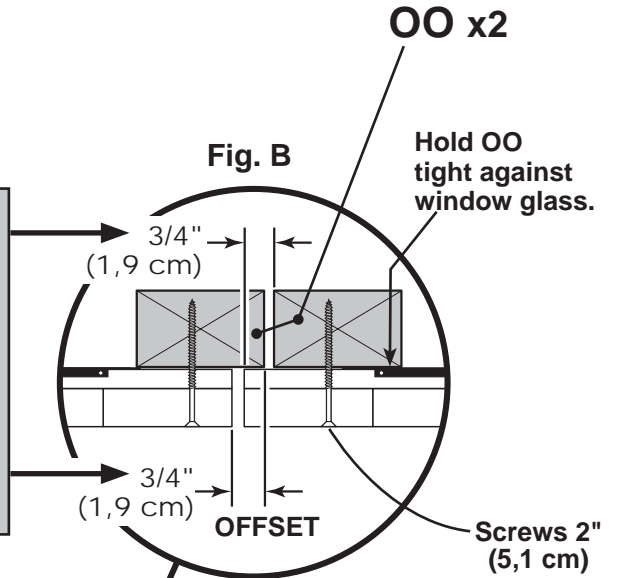
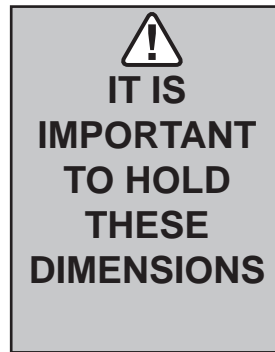
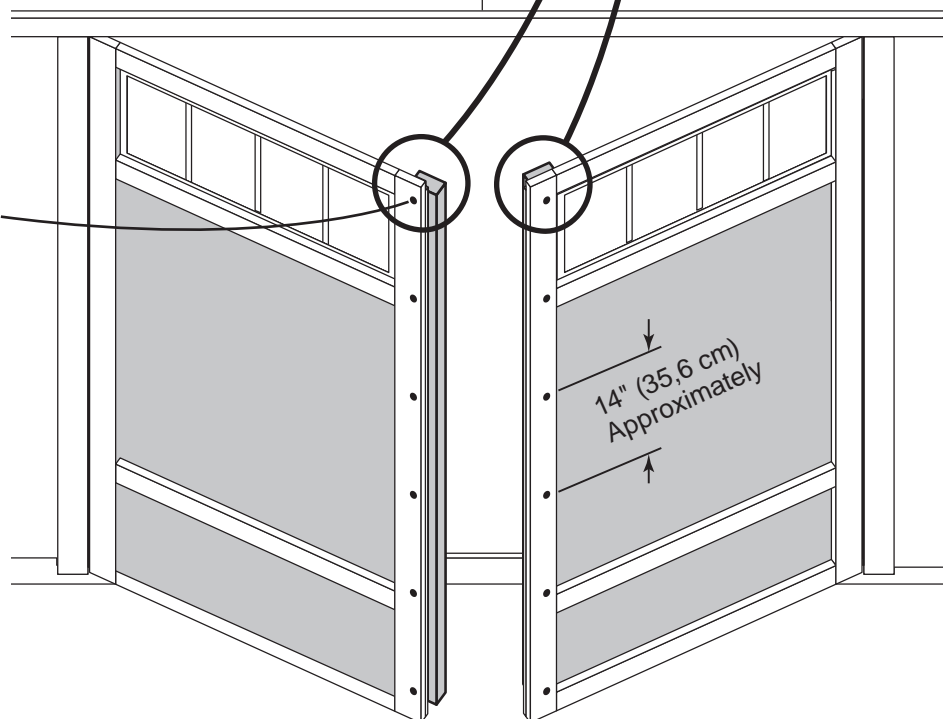

Fig. A



2" (5,1 cm) Screws x12



Your door stiffeners are now installed.

DOOR SPRING BOLTS

PARTS REQUIRED:

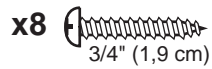
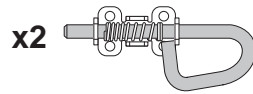

✓ BEGIN

- 1 Place bolt onto OO in open position with bolt end 3/8" down from frame. Bolt is open when loop is contacting base (Fig A).
Mark and pre-drill holes for screws.
- 2 Install bolt with screws supplied and drill 5/16" hole for bolt to extend into.
- 3 Place bolt onto OO in open position with bolt end 1/2" up from floor. Bolt is open when loop is contacting base (Fig B).
Mark and pre-drill holes for screws.
- 4 Install bolt with screws supplied and drill 5/16" hole for bolt to extend into.

Fig. A

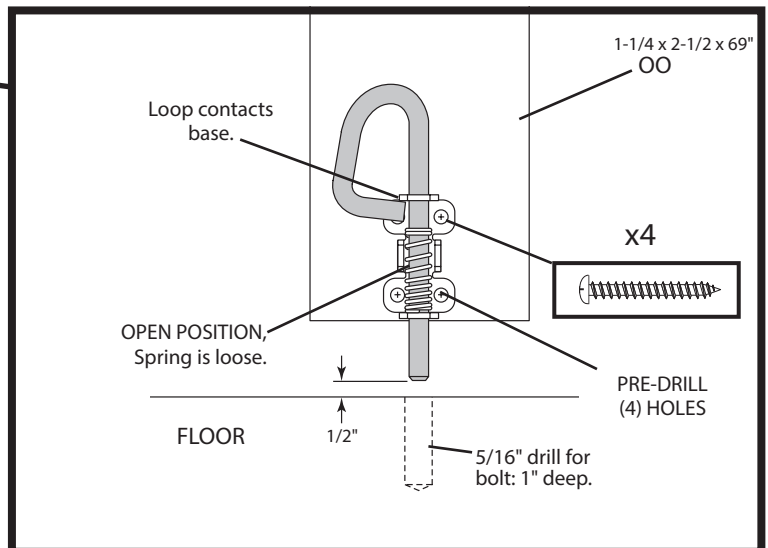
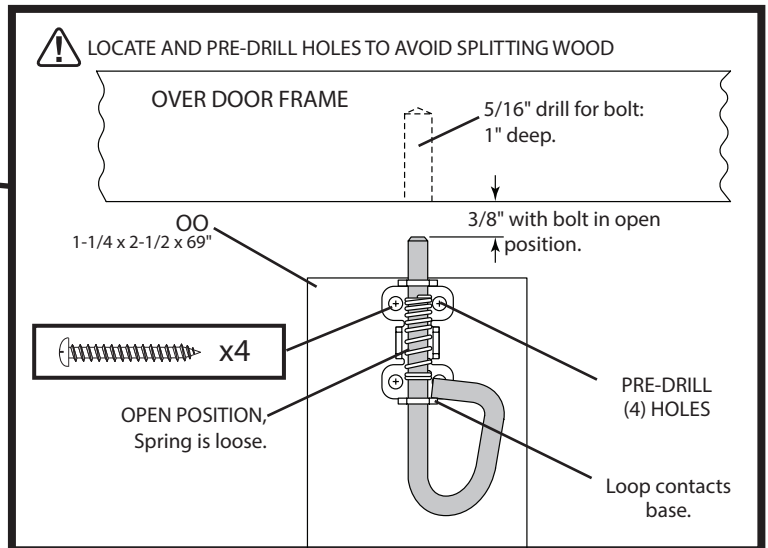
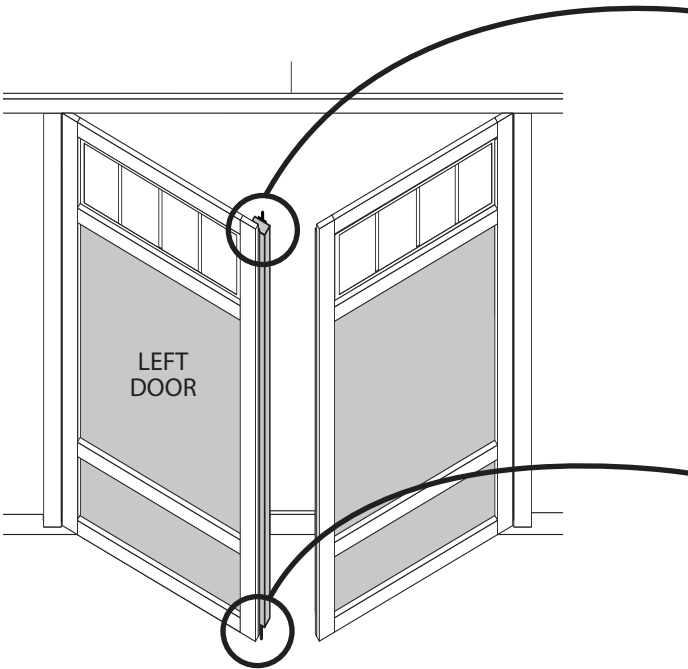

Fig. B



Your spring bolts are now installed.

DOOR HARDWARE / DECORATIVE HINGES

PARTS REQUIRED:

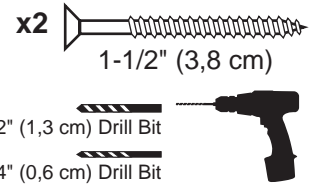
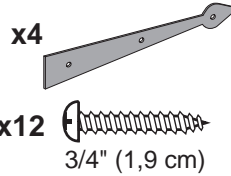
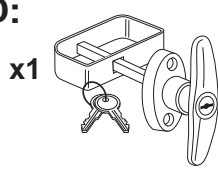

✓ BEGIN

- 1 Measure and mark location of hole on outside of right door as shown (Fig. A).
Pre-drill hole with 1/4" drill.

Re-drill hole with 1/2" drill.



Keep drilled hole square to trim to avoid breaking edge of Door Stiffener.

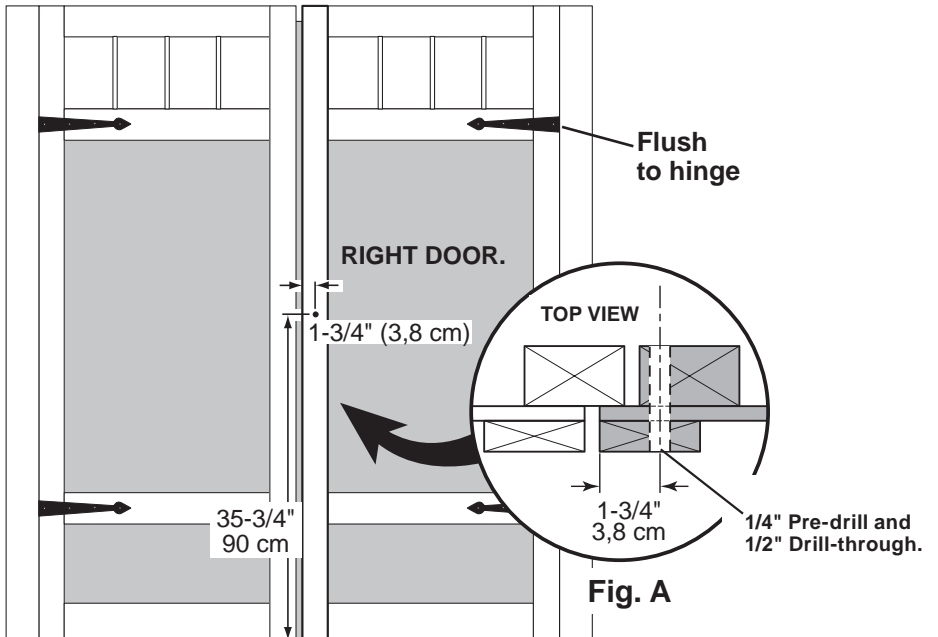

- 2 Insert handle in hole and secure using 1-1/2" (3,8 cm) screws.
- 3 Attach inside handle and secure with set screw as shown.
- 4 Install decorative hinges on horizontal trim and flush against hinge as shown.

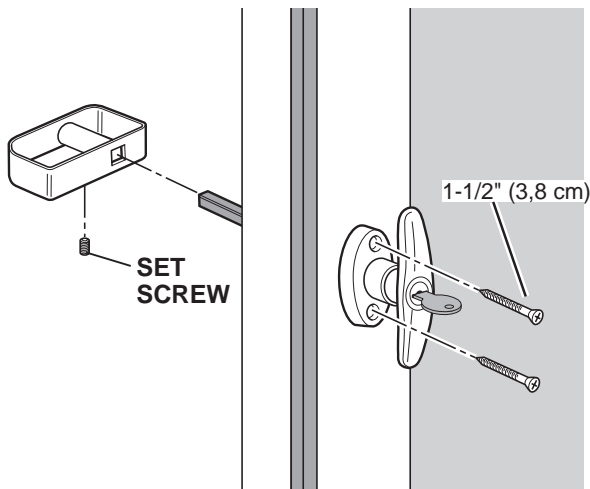

You have now installed your T-handle and decorative hinges.

SHELVING

PARTS REQUIRED:

x6 **QOA**
2 x 3 x 6-1/2" (5,1 x 7,6 x 16,5 cm)

x6  3/8 x 9 x 10"
(1 x 22,9 x 25,4 cm)

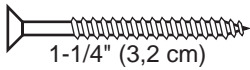
x18  1-1/4" (3,2 cm)

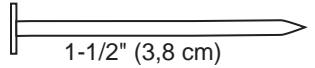
x18  1-1/2" (3,8 cm)



✓ **BEGIN**

- 1 Assemble 6 shelf supports as shown; 4 right-side, 2 left-side.
Secure **QOA** to bracket panels using (3) 1-1/2" nails.

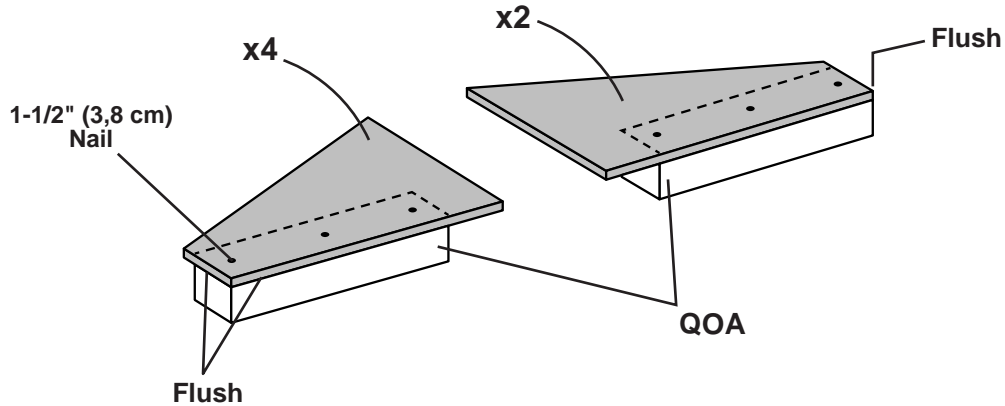

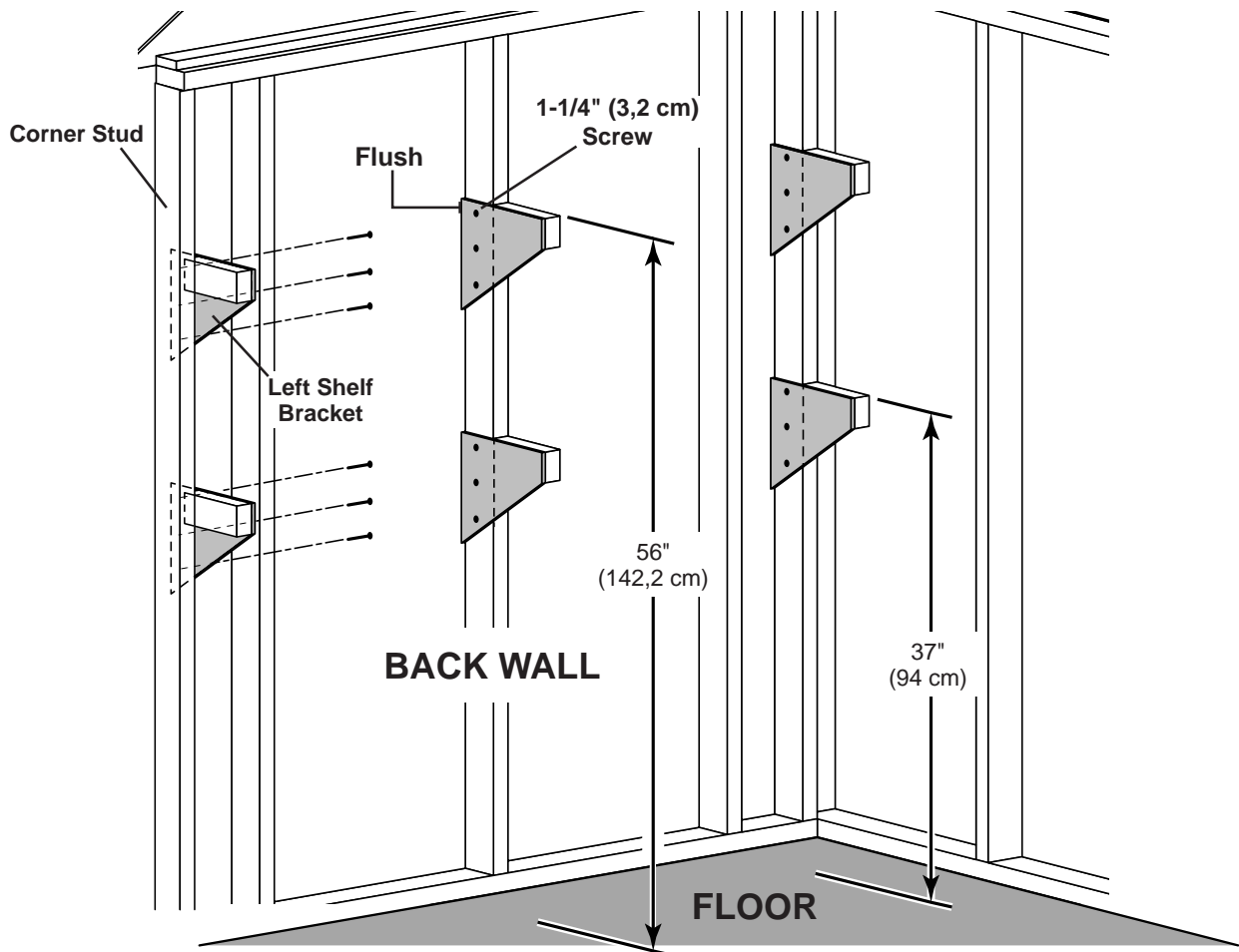

- 2 Install shelf supports at shown height using (3) 1-1/4" screws in each.



SHELVING

PARTS REQUIRED:

x2  7/16 x 7-7/8 x 72" (1,1 x 20 x 182,9 cm)

x2 **HJ**  1 x 3 x 72" (2,5 x 7,6 x 182,9 cm)

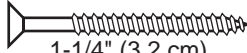
x12  1-1/4" (3,2 cm)

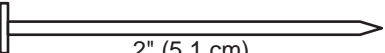
x12  2" (5,1 cm)



3 Install shelf panels centered over shelf supports. Secure using 1-1/4" screws at each support.

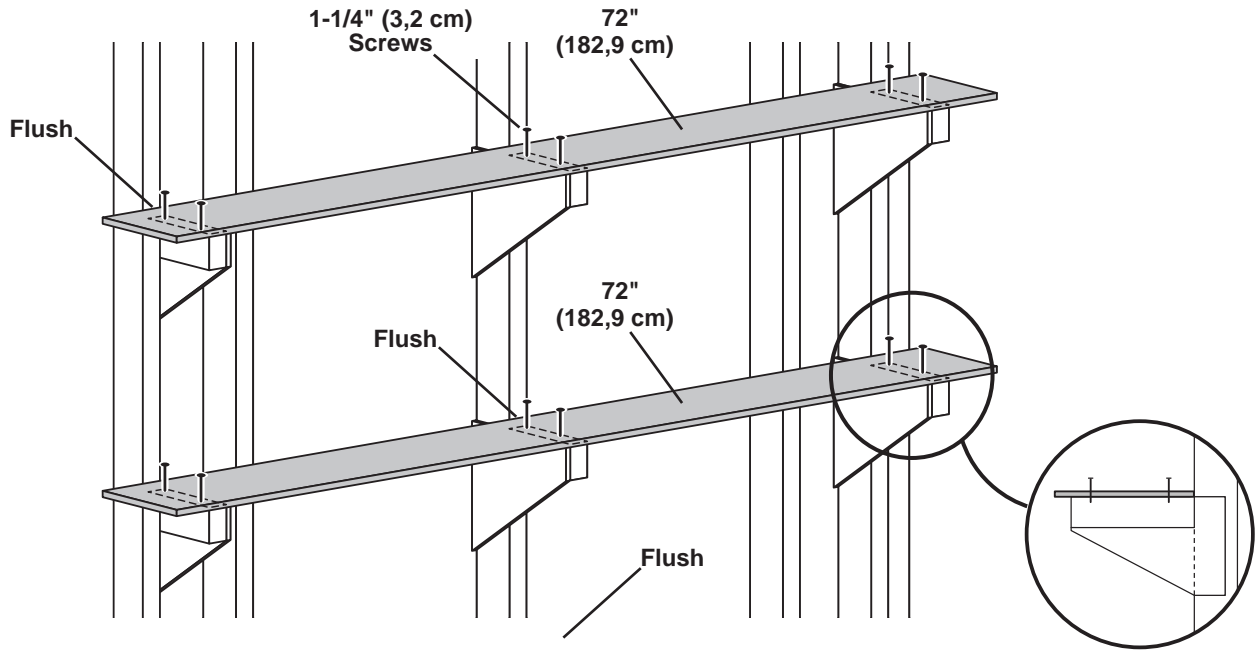

4 Center under shelf panels **HJ**. Secure using 2" nails at each shelf support as shown.

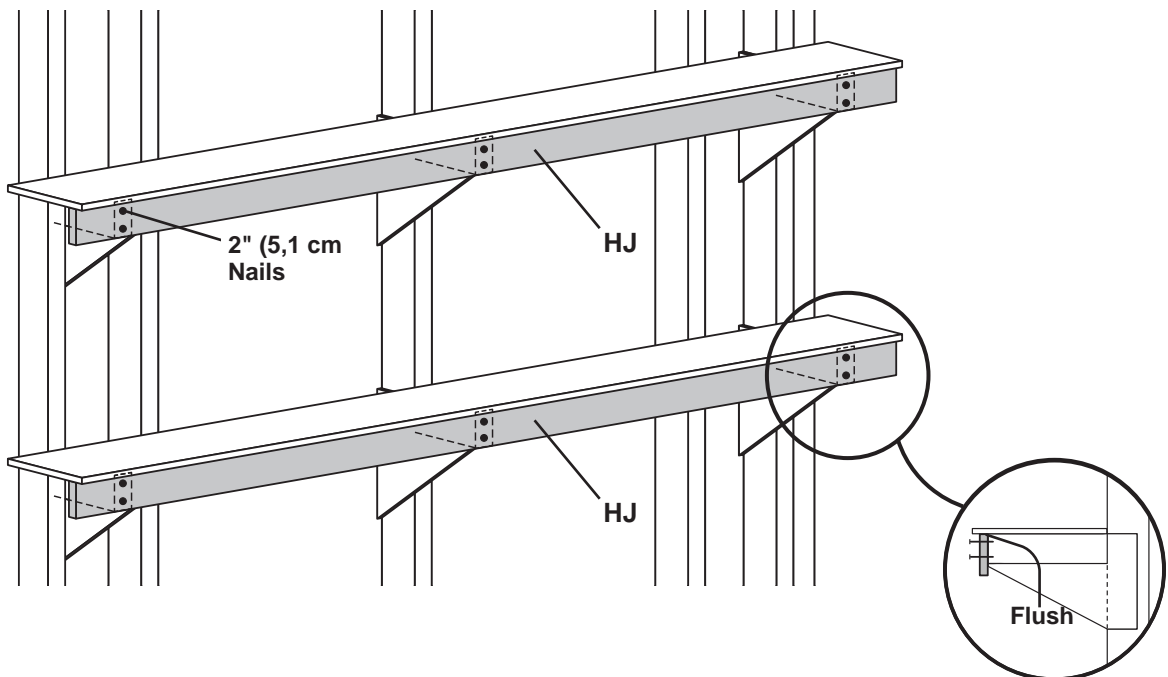

Your shelves are now installed.

GABLE VENT

PARTS REQUIRED:

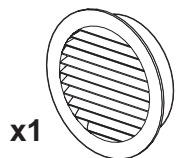

✓ BEGIN

1 Apply high quality exterior-grade caulk behind frame near edge before installing to seal vent.

2 From outside of shed, position vent in opening and level.

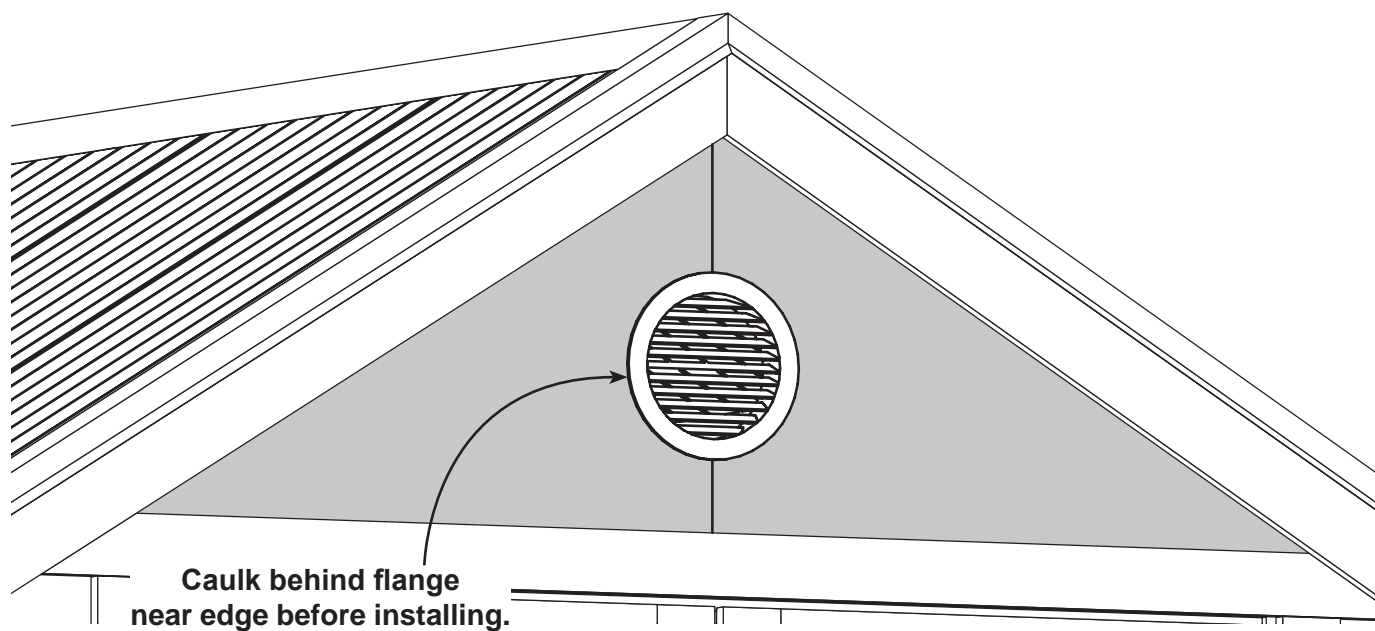

Your gable vent is now installed.

LIMITED CONDITIONAL WARRANTY*

Backyard Storage Solutions, LLC warrants the following:

1. Every product is warranted from defects in workmanship and manufacturing for 1 year.
2. All accessories, hardware and metal components are warranted for 2 years.
3. All Oriented Strand Board (OSB) is warranted for 2 years
4. Siding and Trim is warranted for 15 years.
5. LP Prostruct® Flooring is warranted for 10 years
6. Cedar lumber is warranted for 15 years.
7. Preserved Pine is warranted for 10 years.
8. Redwood is warranted for 10 years.
9. Metal Roof is warranted for 25 years.

Backyard Storage Solutions, LLC will repair, replace or pay for the affected part. In no event shall Backyard Storage Solutions, LLC pay the cost of labor or installation or any other costs related thereto. All warranties are from date of purchase. If a cash refund is paid on an affected part, it will be prorated from the date of purchase.

CONDITIONS

The warranty is effective only when:

1. The unit has been erected in accordance with the assembly instructions.
2. The unit has been properly shingled and painted or stained and reasonably and regularly maintained thereafter.
3. The failure occurs when the unit is owned by the original purchaser.
4. Backyard Storage Solutions, LLC has received the warranty registration card within thirty (30) days of purchase and notification of the failure in writing within the warranty period specified above.
5. Backyard Storage Solutions, LLC has had reasonable opportunity during the sixty (60) days following receipt of notification to inspect and verify the failure prior to commencement of any repair work.

REQUIREMENTS

Storage Buildings

To validate your warranty, it is necessary to properly maintain your Backyard Storage Solutions, LLC unit; shingle the roof and paint or solid-colored stain the siding using quality, 100% acrylic latex exterior product with a minimum of two (2) coats within thirty (30) days of assembly; caulk above all doors and all horizontal and vertical trim boards; paint and seal all exposed edges, sides and faces of siding/trim and OSB siding to include all exterior walls and all sides and all edges of doors.

Gazebos & Pergolas

To validate your warranty, it is necessary to properly maintain your Backyard Storage Solutions, LLC unit. This includes treating all of the exposed cedar and pine surfaces on your gazebo or pergola structure with an exterior grade wood preservative, an exterior oil-based semi-transparent stain, an acrylic latex exterior paint or an acrylic latex solid color exterior stain within 30 days of assembly and as needed thereafter to maintain your warranty.

Keep vegetation trimmed away from building and make sure siding panels and trim do not come in contact with masonry or cement. The minimum ground clearance for siding must be one half inch (½ inch) from concrete slab or two and one half inches (2 ½") from the ground when building is erected or constructed on a treated wood floor kit. Water from sprinklers must be kept off unit. In no event will Backyard Storage Solutions, LLC be responsible for any indirect, incidental, consequential or special damages nor for failure(s) that are caused by events, acts or omissions beyond our control including, but not limited to, misuse or improper assembly, improper maintenance (which eventually leads to rot or decay) and acts of God. Backyard Storage Solutions, LLC will not be held responsible for any labor costs incurred to construct your unit.

This warranty gives you certain specific rights that vary from state to state.

CLAIM PROCEDURE

To make a claim under this warranty, you can either call 1-888-827-9056 or email: customerservice@backyardproducts.com.

Please have ready the information below when you call or include the information in your email:

1. The model and size of the product.
2. A list of the part(s) for which the claim is made.
3. Proof of purchase of the Backyard Storage Solutions, LLC item, as shown on the original invoice or receipt.
4. Run code: found on exterior product label or assembly instructions enclosed in the product package.

All other inquiries can be mailed to:

Backyard Storage Solutions, LLC
Attn: Customer Service
1000 Ternes
Monroe, MI 48162

***WARRANTY TERMS MAY VARY OUTSIDE THE U.S.A.**

IMPORTANT: This is your warranty certificate.

15Y PSS BB GEN LDR: 3/20/2019