

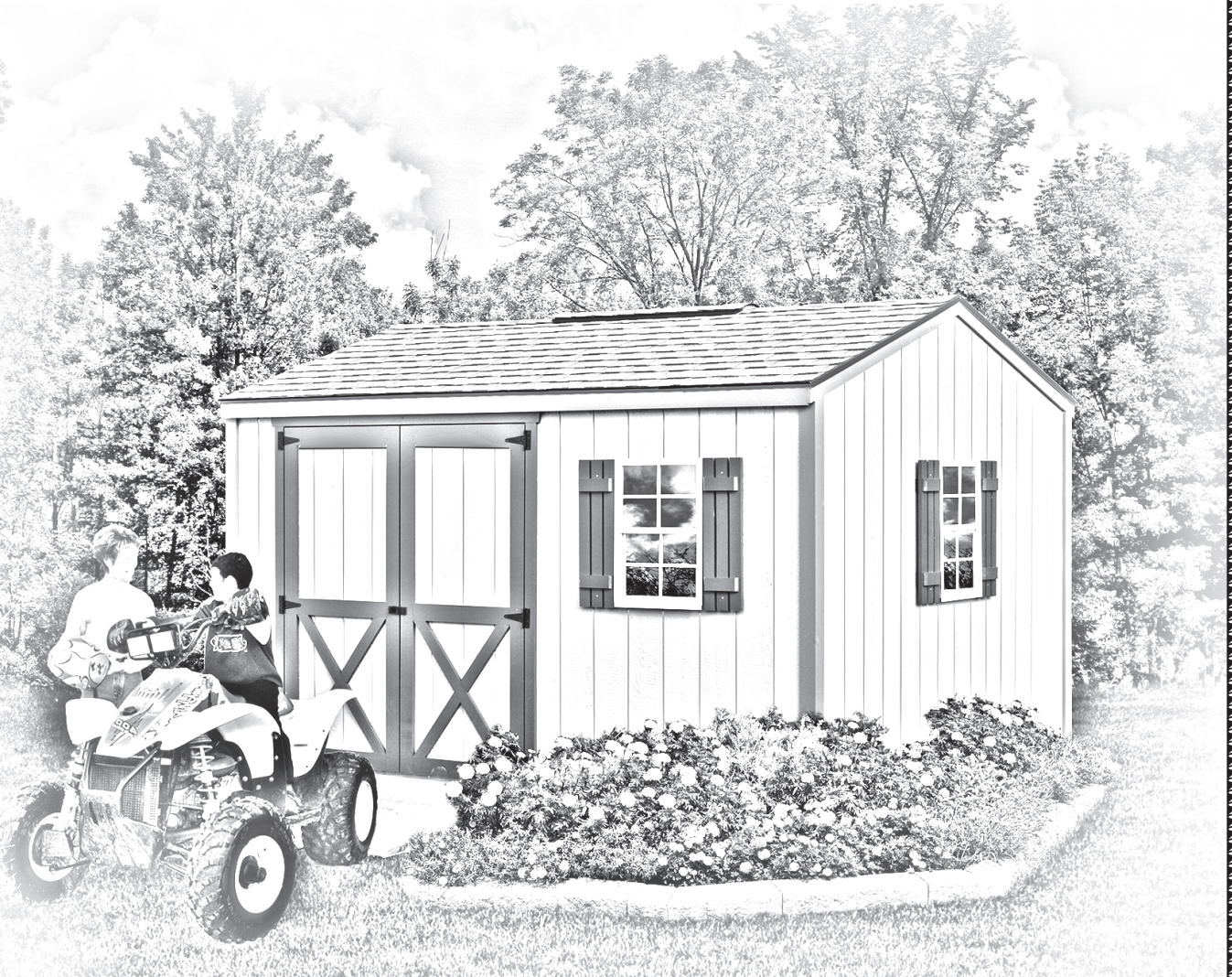

Assembly Book
revised February 5, 2026



Handmade Haven ***10' x 12'***

Manufactured by RBS Holdings, LLC
205 Arlington Drive Greenville, PA 16125

This manual is copyrighted. Under the copyright laws, this manual may not be copied, in whole or in part, without consent from RBS Holdings, LLC © Copyright 2022

IMPORTANT INFORMATION ABOUT YOUR KIT

Thank you for purchasing our kit. Please read the following information before beginning construction. Always check with your local HOA or building code office for any requirements or restrictions.

Floor: Wood flooring is sold optionally. You may choose to build your own or pour a cement pad.

Always wear safety glasses when cutting or nailing!

Tools Required: Hand or Circular Saw
Cordless Drill
Hammer
Pencil

Level
Measuring Tape
6'-8' Ladder(s)

Safety Glasses
Dust Mask
Phillips Screwdriver
Framing Square

Additional Materials - **Not included in kit:**

Required: Shingles or metal roofing, Drip Edge, Roofing Nails or Screws, Paint

Optional: Caulk, Ridge Vent

Terminology:

Square - Confirm corners are at 90 degrees

Plumb - Confirm walls and trusses are straight vertically

Wall Plate - Top and bottom 2x4s used to frame walls

Tie Plate - 2x4s connecting wall sections together

Header - Spans top of door opening

OSB - Oriented Strand Board

LAP - Edge of siding that overlaps

Tongue - Edge of siding that is overlapped

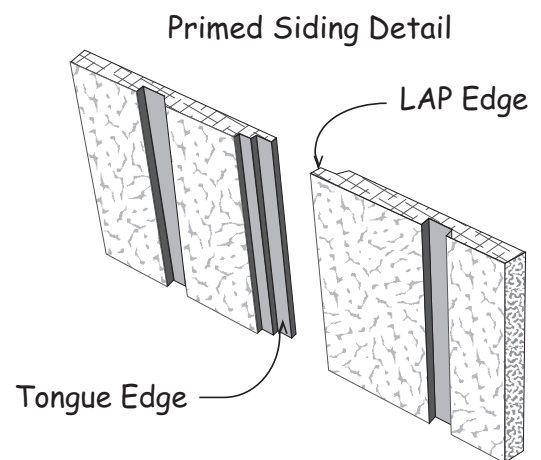

Organize:

Unpack all items & organize according to size and type. This will make items easier to find when instructed.

Review the parts list on the back page. Should there be missing items or sub-par material contact Best Barns Customer Service.

DO NOT discard any material including the pallet until your project is complete.

Assembly:

Review all instructions before you begin. Please follow steps carefully and in sequence for successful results.

If you have any questions we are happy to assist you. Please contact us at:

Sales / Support 7am - 11pm CDT,

7 Days a Week

Phone 1-877-307-4337

Email - support@shedsforlessdirect.com

Construction Details for Optional Floor System

Check local building codes in your area, the construction may have to change. For a concrete slab, install sill sealer as a moisture barrier between the concrete and the wall plates. Foam sill sealer can be purchased at home centers in rolls 3-1/2" or wider.

1. Treated lumber is not cut to exact length. Cut (2) two 2x4-12' boards to 12'-0". Layout for 16" on center joist spacing. 'X' marks where floor joist will be placed.

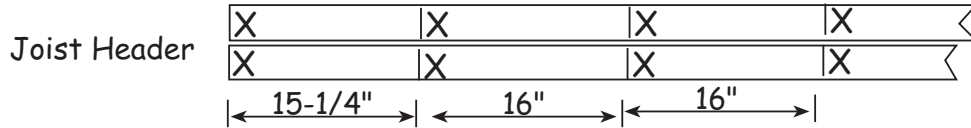

2. Cut (10) ten 2x4-10' floor joist to 9'-9". Treated lumber may be thicker than 1-1/2". Take this into account when cutting the length of floor joists. Shorten joist measurements if necessary to obtain 12'-0" building width.
3. Install the floor joist, over the 'X' marks, between the 12' long joist headers. Use 16d galv. deck nails.

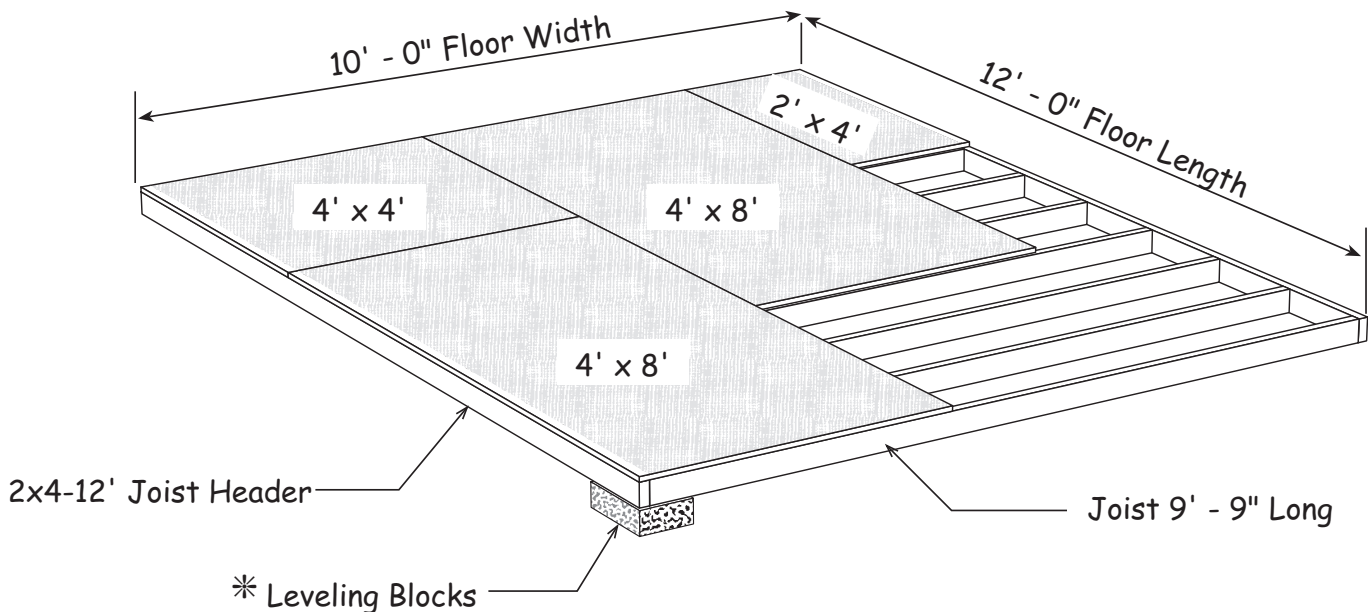

* If necessary use bricks, patio stones or similar material to level or provide additional support to the floor. If your ground has low areas consider adding gravel and or 4x4 treated timbers to rest the floor on. If you use 4x4 timbers you will need (3) three pieces 12' long.

It is important that the floor be level and square. Before nailing the flooring, measure the floor diagonally (corner to corner). Then measure the opposite corners. These measurements will be the same if the floor is square (187-1/2").

Material Description	10' x 12' Floor
2x4 Treated Headers	2 pcs. 12'
2x4 Treated Floor Joist	10 pcs. 10'
Flooring 5/8" 4x8	4 pcs. 4x8
8d Screw Floor Nails	1 lb. 8d
16d Galv. Box Nails	1 lb. 16d

Step 1 Assemble Roof Gables and Trusses

 *Gables will have (1) one gusset applied. Trusses will have (2) two gussets.*

Tip: If possible, temporarily screw 2x4 blocks to the floor using 2-1/2" deck screws. Short 2x4s, that may have an angle on one end, supplied in the kit for this purpose. This will secure the gable and truss boards in position so all the trusses will be assembled the same.

1. Place (2) two 62" long 2x4 boards with angled ends together as shown below to make a gable. Hold in place with 2x4 blocks as shown. Make sure the gable measures 10'-0" wide when assembled to fit properly when installed
2. Secure the tops together with a 24" wide OSB gusset. Nail the gusset to the 2x4s with (14) fourteen 6d common nails. Angle nails slightly so nails do not protrude through the 2x4 boards.
3. Repeat to assemble (1) one more gable for a total of (2) two gables.
4. Select (2) two 62" long 2x4 boards with angled ends to make the first truss. Secure the tops together with a 24" wide OSB gusset. Turn truss over and install another 24" wide OSB gusset.
5. Repeat steps to assemble (4) four more trusses.

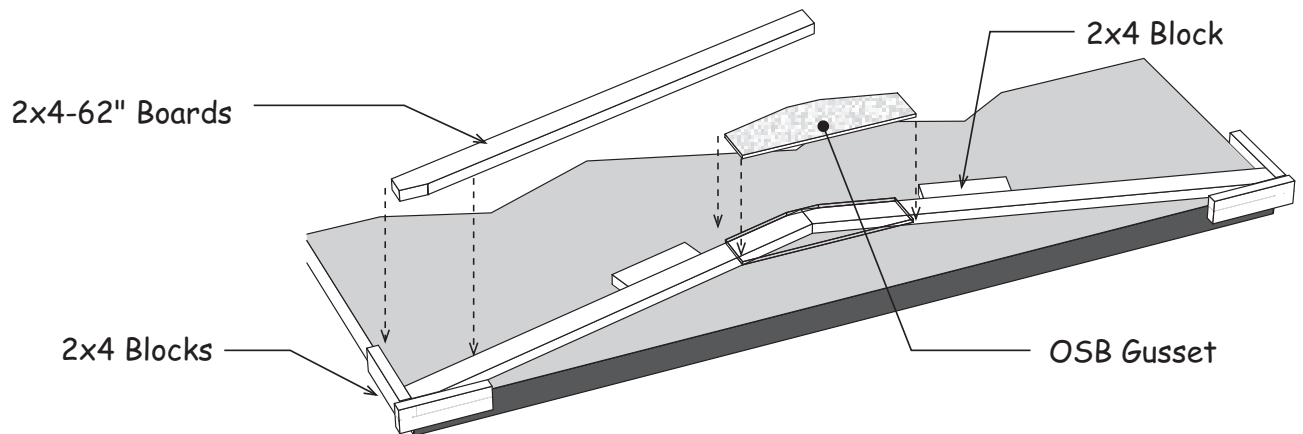

Step 2A Assemble End Walls

1. Position (4) 60" boards together and indicate with 'X' marks, where the wall studs will be located. Mark the ends that will butt together with the letters 'A' and 'B'.

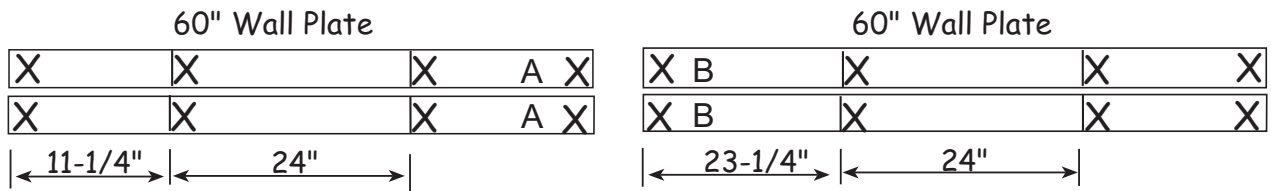

2. Install 72" wall studs between the top and bottom plates. Assemble wall frames with 10d sinkers. Use (2) two nails at end of each wall stud.
3. Nail both wall frames together with (4) four 10d sinkers on each side.

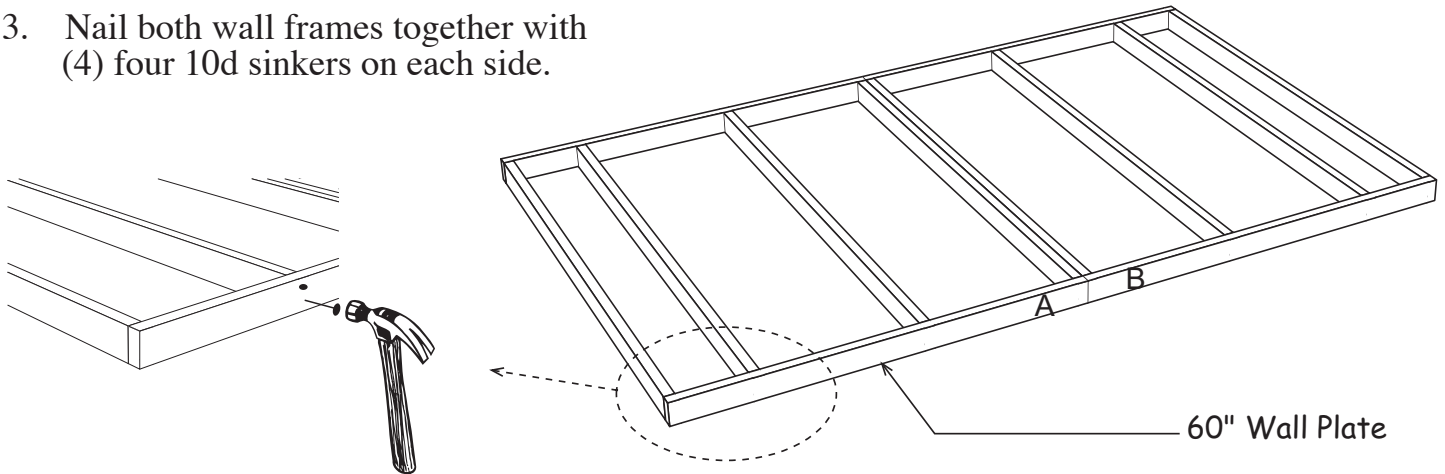

4. Square frame, *measure diagonally (corner to corner)*. The measurement should be 141-1/2".
5. Repeat steps 1-4 to assemble next end wall frame.
6. Select a 36-3/4" wide siding panel with a 'tongue' edge. Install this panel with the 'Cut' edge flush with the end of the wall frame. Install siding flush with the 2x4 top plate. Use 6d galv. nails spaced 8" apart.
7. Install a full width x 75-3/4" long siding panel next.
8. Install a 36" x 75-3/4" siding panel last. If necessary trim panel flush with 2x4.

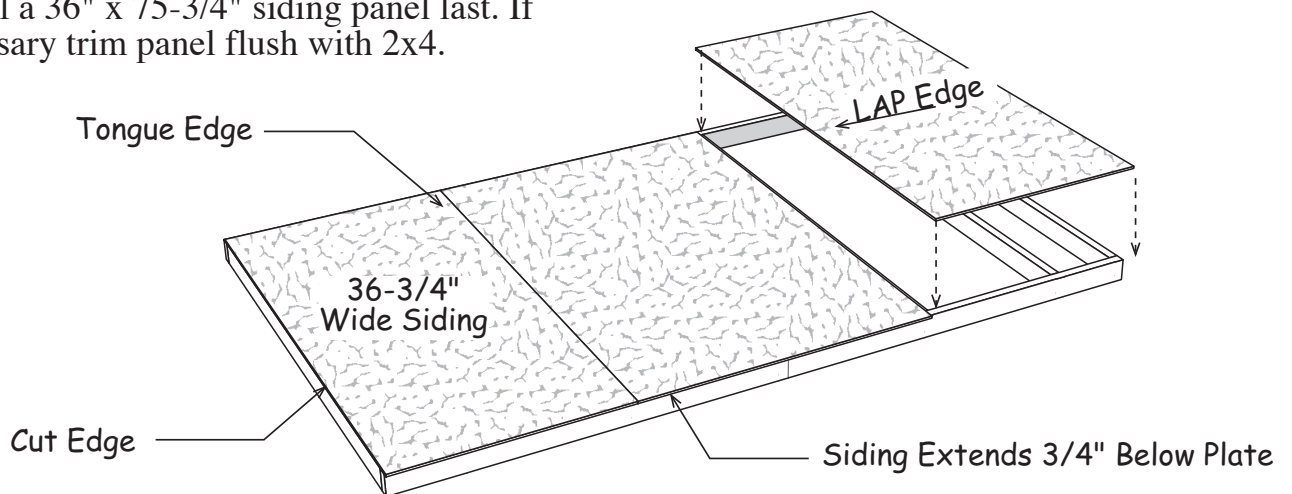

Step 2B Assemble End Walls Continued

9. Install a 68-1/2" long 2x4 in the center of the wall panel, at the top. Use (6) six 10d sinkers. Set wall aside.

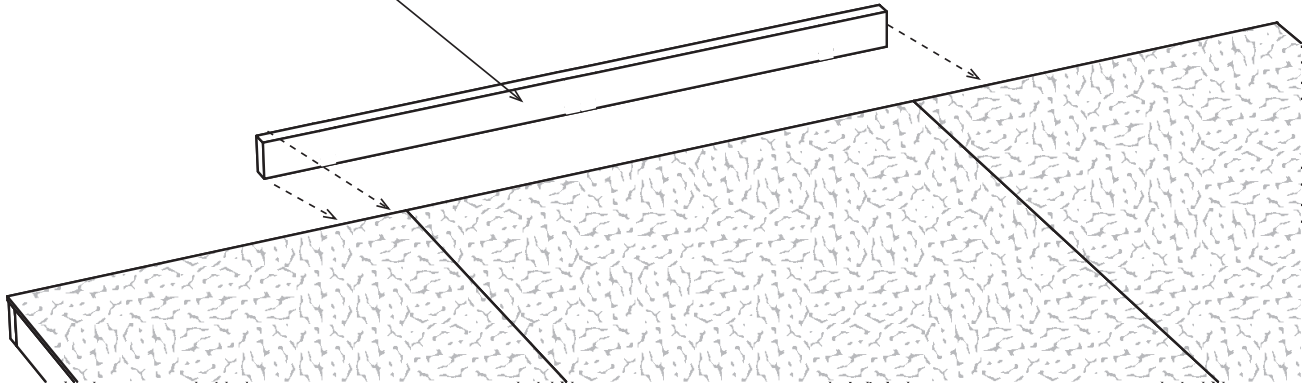

10. Select the other end wall frame.
11. Square wall frame. Select a 12-1/2" wide siding panel with a 'tongue' edge. Install this panel with the 'Cut' edge flush with the end of the wall frame. Install siding flush with the 2x4 top plate.
12. Install (2) two full width x 75-3/4" long siding panel next.
13. Install a 11-3/4" x 75-3/4" siding panel last. If necessary trim panel flush with 2x4.

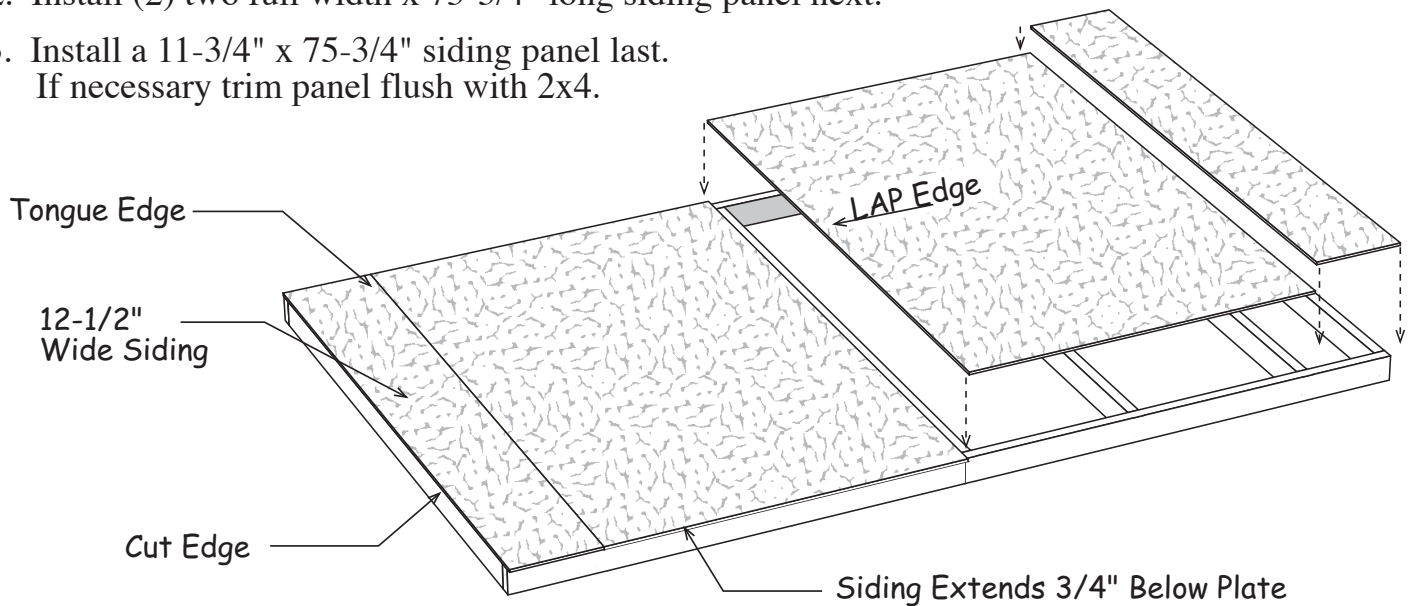

14. Install a 68-1/2" long 2x4 in the center of the wall panel.

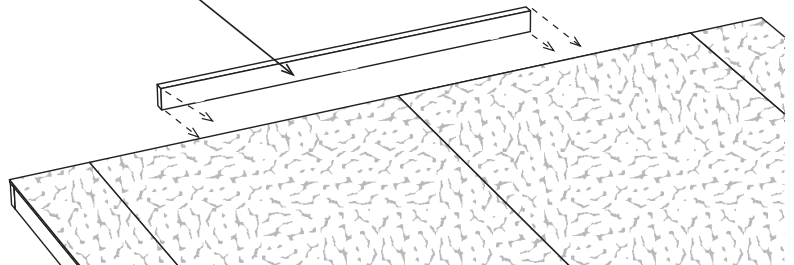

Step 3 Assemble Back Wall

1. Position (4) four 68-1/2" boards together and indicate with 'X' marks, where the wall studs will be located. Mark the ends that will butt together with the letters 'A' and 'B'.

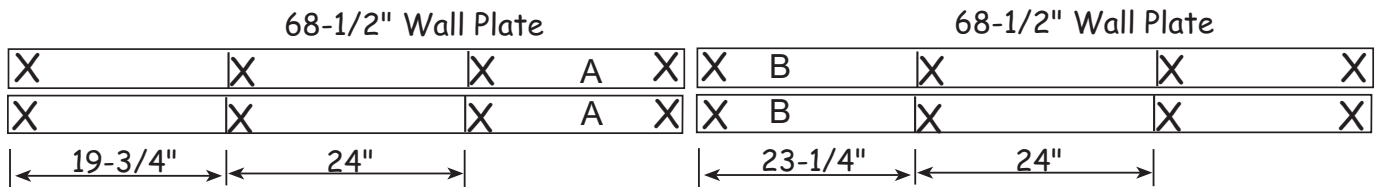

2. Install 72" wall studs between the top and bottom plates. Assemble wall frames with 10d sinkers. Nail both wall frames together.

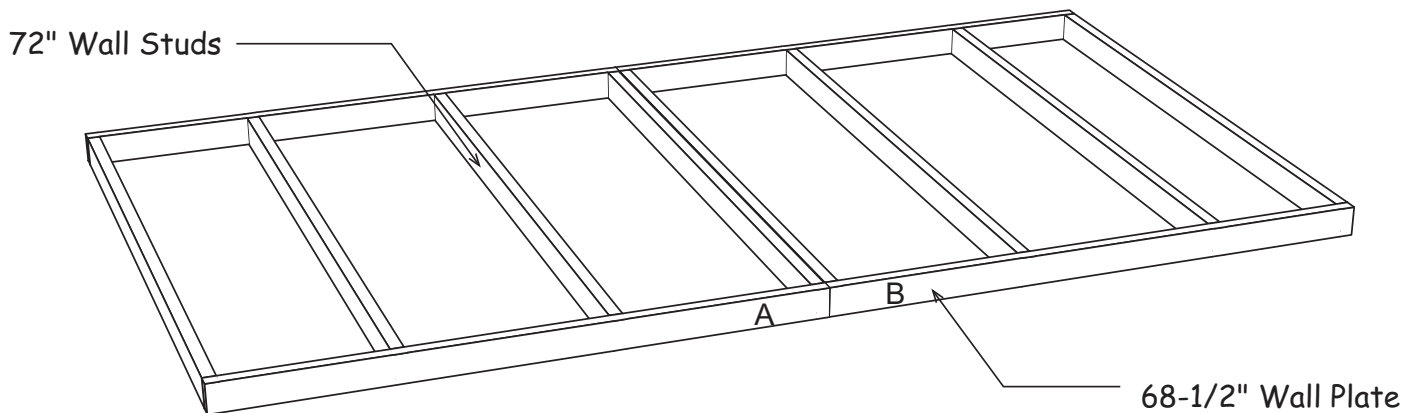

3. Square wall frame. The measurement should be 156-1/4". Install (3) three full width siding panels. Install the first siding panel with the 'LAP' edge extending 3-1/2" past the end of the wall frame. The last panel should extend 3-1/2" past frame. The siding should extend 3/4" below the bottom plate and flush with the top plate.

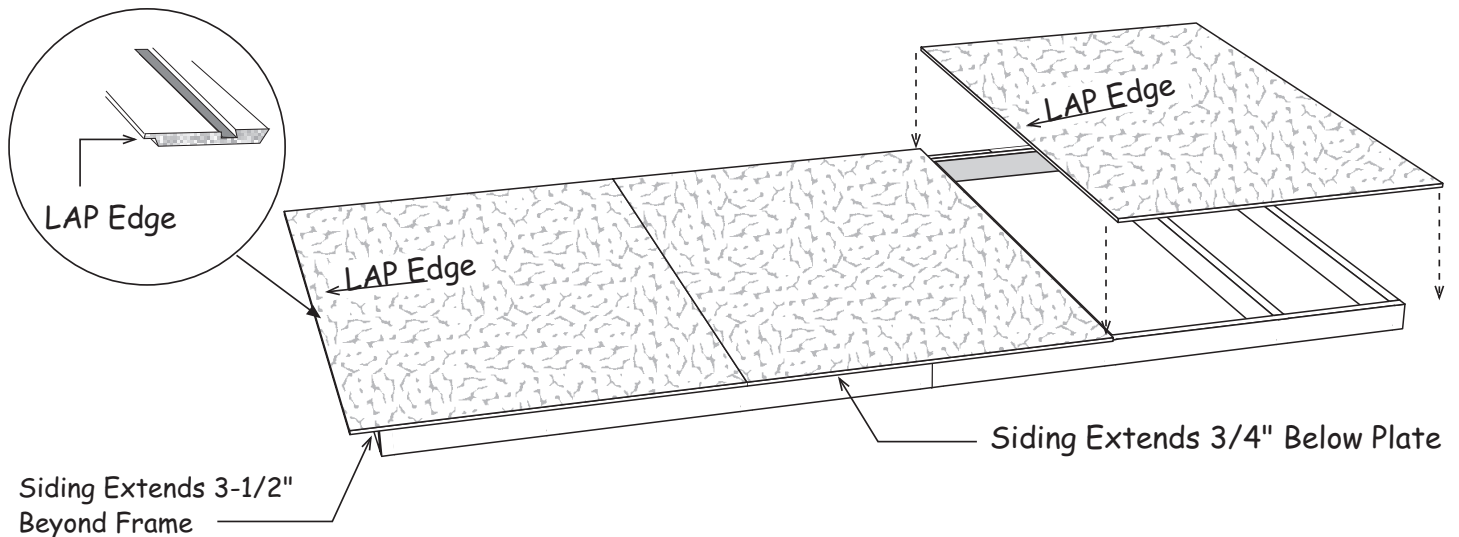

Step 4 Assemble Front Wall Frames

1. Cut (2) two 72" long 2x4s to 71-1/2" for use as header supports.
2. Cut (2) two 60" long 2x4s to 58-1/2" for use as top and bottom plates.
2. Select a 68-1/2" long 2x4. Cut (2) two boards to 11" in length for use as top and bottom plates. Save the leftover 2x4, it will be used in a later step.

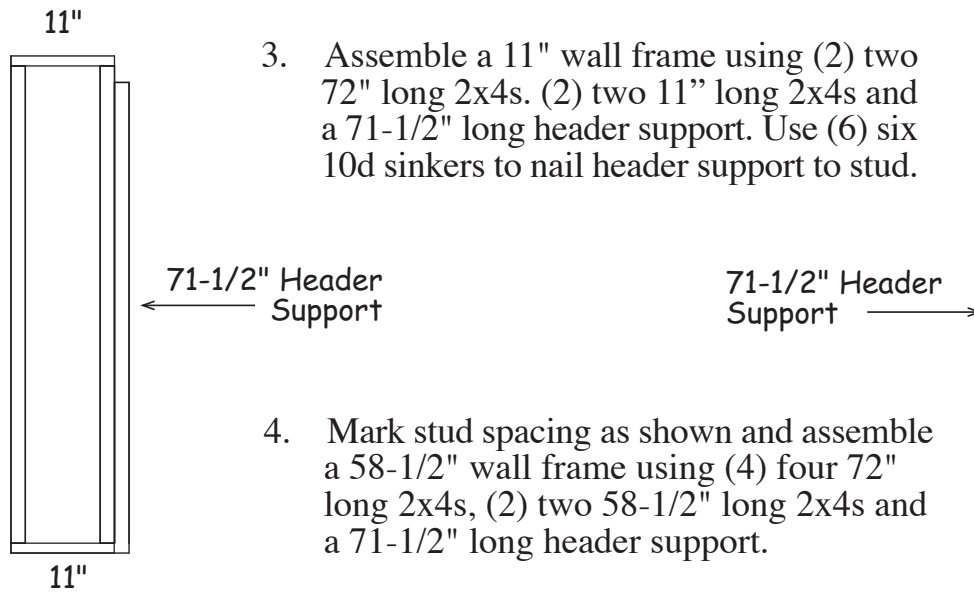

3. Assemble a 11" wall frame using (2) two 72" long 2x4s, (2) two 11" long 2x4s and a 71-1/2" long header support. Use (6) six 10d sinkers to nail header support to stud.

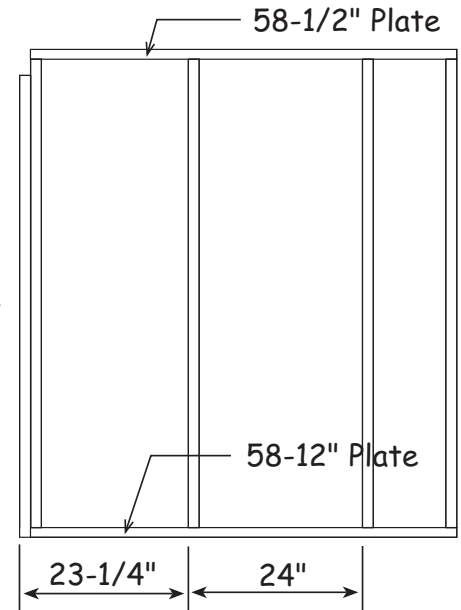

4. Mark stud spacing as shown and assemble a 58-1/2" wall frame using (4) four 72" long 2x4s, (2) two 58-1/2" long 2x4s and a 71-1/2" long header support.

Step 5 Set Walls

 If you want the door opening to be on the right, reverse the un-sided wall frames.

1. Erect wall panels. **IMPORTANT: Make sure walls are plum and square.** Secure wall panels together at the corners. Use (4) four 10d sinkers per corner. Nail wall panels to the floor through the bottom plate. Use 10d sinkers or, if erecting on a concrete slab, concrete anchor bolts (not included) spaced 24" apart.

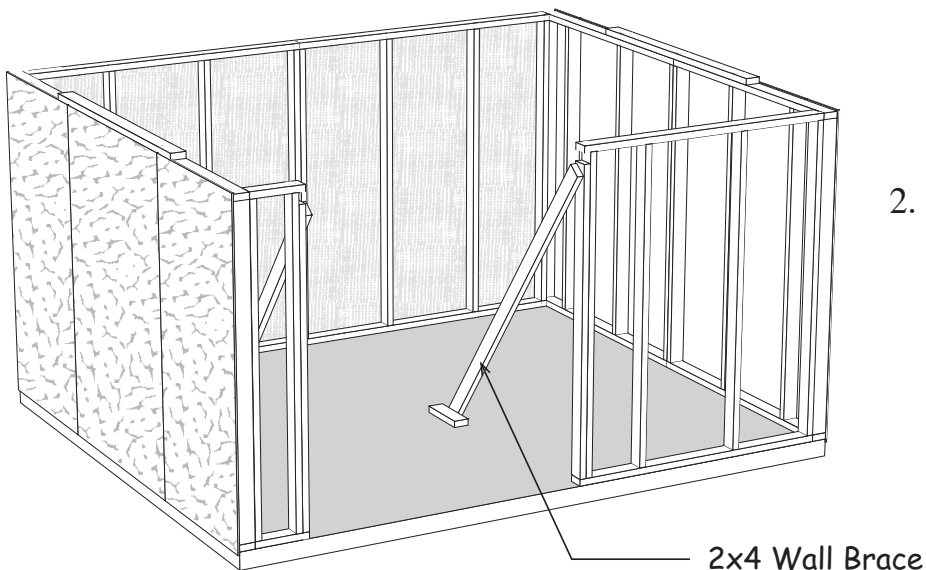

2. Temporarily use (2) two 72" long 2x4s to brace the front door wall frames.

Step 6 Install Header

1. Gather (2) two 67-1/2" long 2x4 boards and a 3-1/4" x 67-1/4" OSB filler panel. Nail header together from both sides with 10d sinkers staggered 6" apart.
2. Install header on top of header supports. Nail through studs with 10d sinkers.

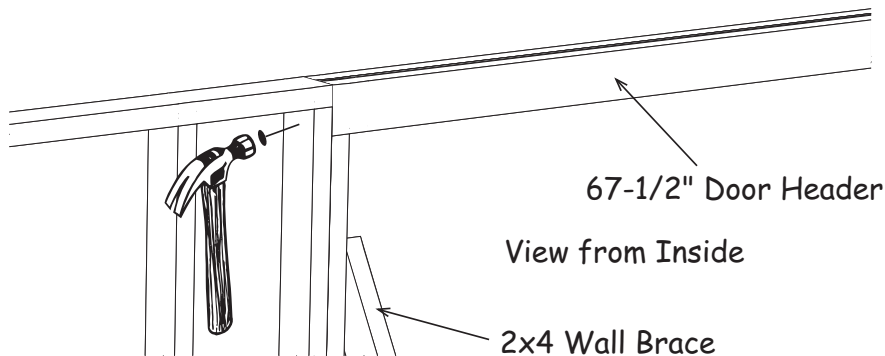
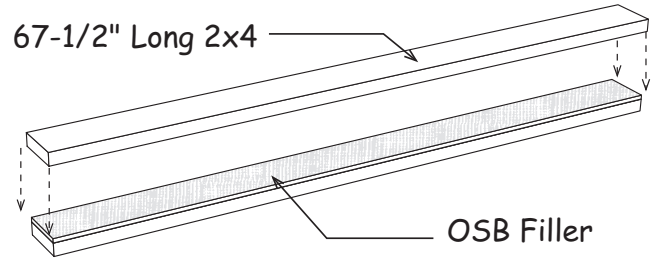

Step 7 Install Siding on Front Wall

1. Select a 16-1/2" siding panel with a 'Tongue' edge and install at the front left corner with the 'Cut' edge flush with siding on the end wall. The 'Tongue' edge should be flush with door opening.
2. Install (2) two 4-3/4" x 32-1/4" siding panels over the door opening. Bottom of siding should extend 3/4" below header. Trim will cover where the siding panels butt together in the center.
3. Select and install a full width siding panel next.

4-3/4" x 32-1/4" Siding Panels

4. Install last siding panel.

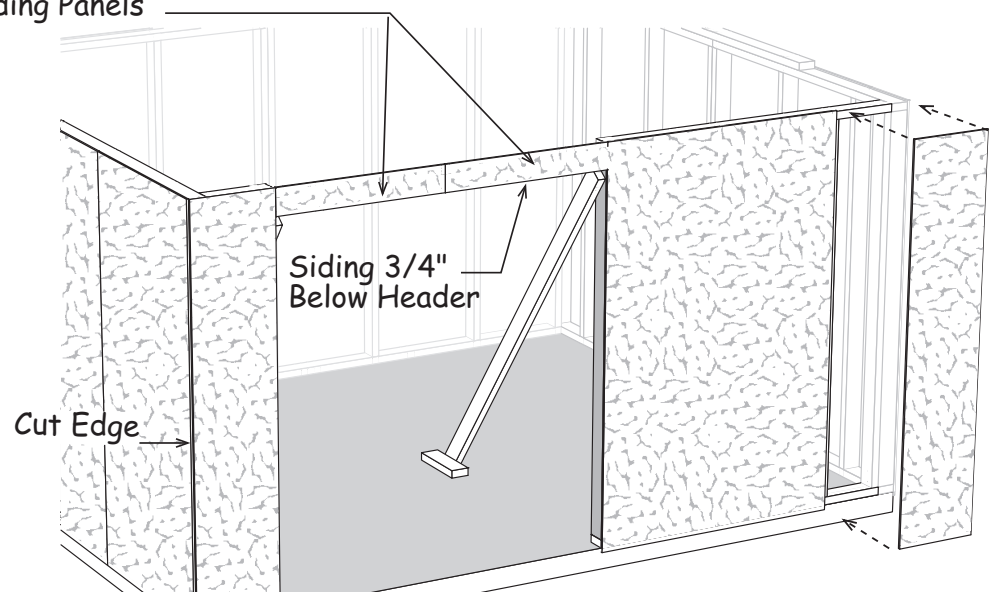

Step 8 Install Tie Plates

1. Remove the 2x4s bracing the front wall and cut (4) four 36" long boards from these. Install one of the 36" long boards over the back wall flush with the 2x4 top plate on end wall. Use 10d sinkers spaced 16" apart.
2. Install a 72" long 2x4 and finish with another 36" long 2x4.
3. Repeat to install tie plates on the front wall.
4. Cut (3) three 22-1/4" long 2x4s from a 68-1/2" board. Cut one more from the leftover 2x4 from **Step 4**.
5. Install the 22-1/4" boards on the end walls, see below.

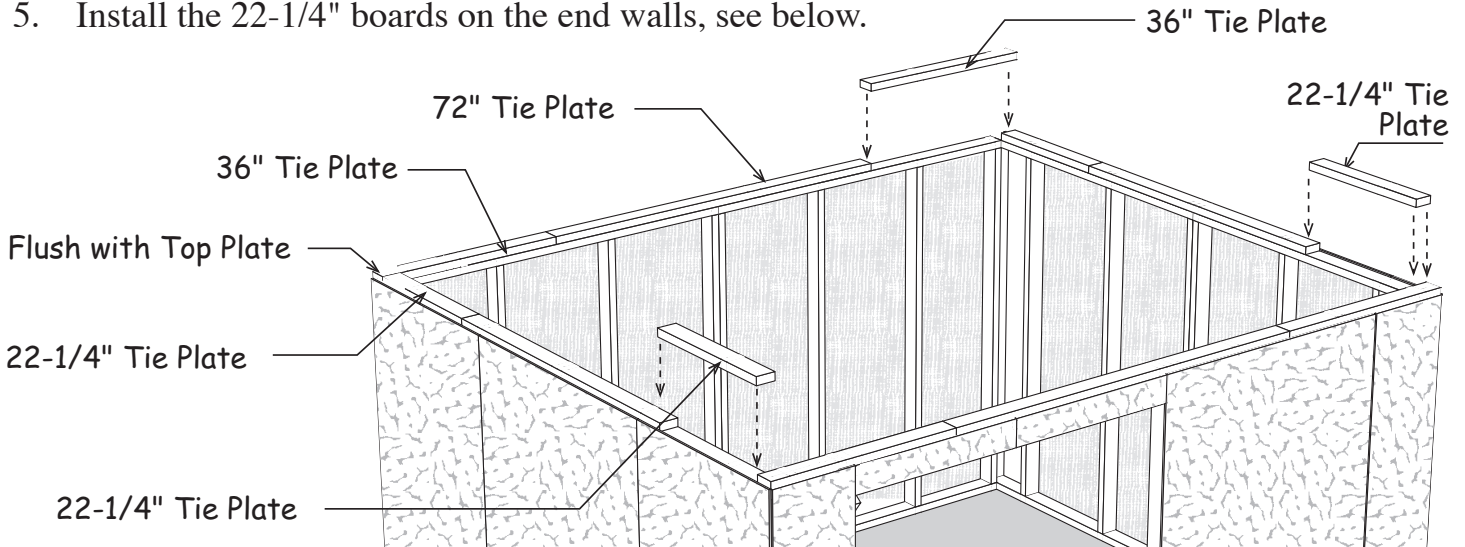

Step 9 Install Roof Gable

1. Select a truss with a gusset installed on one side. Position this truss with the gusset facing towards the inside of the building and flush with 2x4s on end wall.
2. Install a 10" to 12" long 2x4 block on the back wall using 10d sinkers. Secure the truss to the 2x4 block with (2) two 10 sinkers.
3. Install a 2x4 block on front wall and secure the truss.

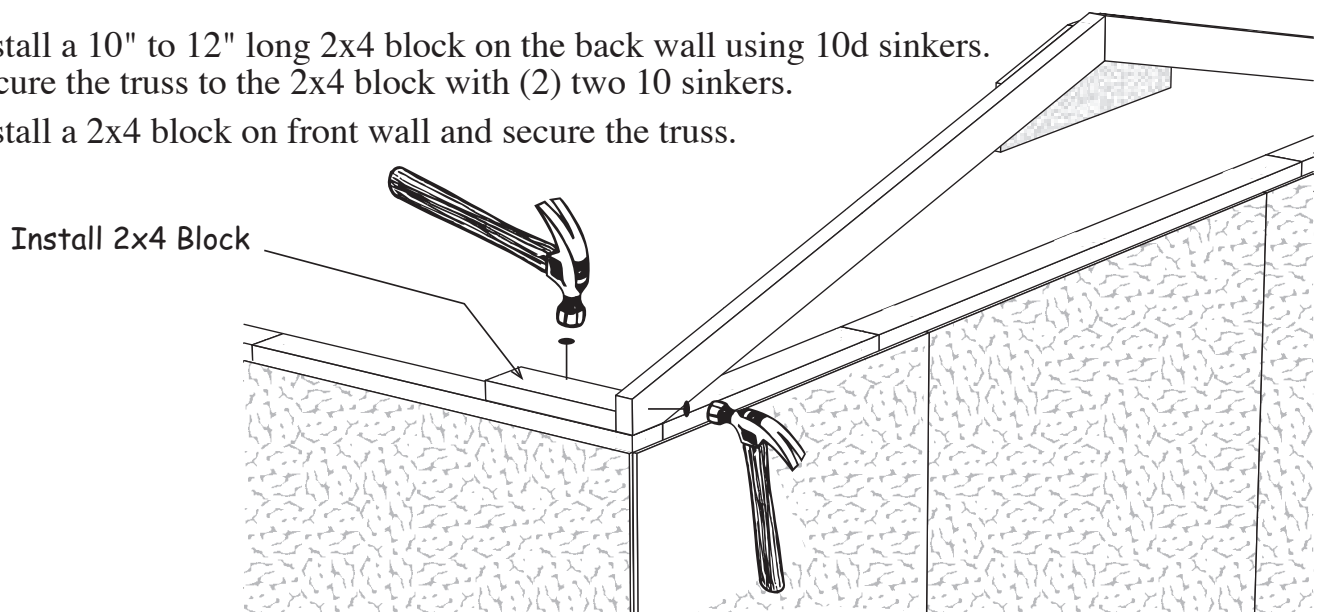

Step 9 Install 'Z' Flashing

Install (2) two 60" pieces of 'Z' flashing across the top of the siding on the end wall siding. Secure in place using 6d galv. nails spaced 12" apart. The ends will be covered by corner trim.

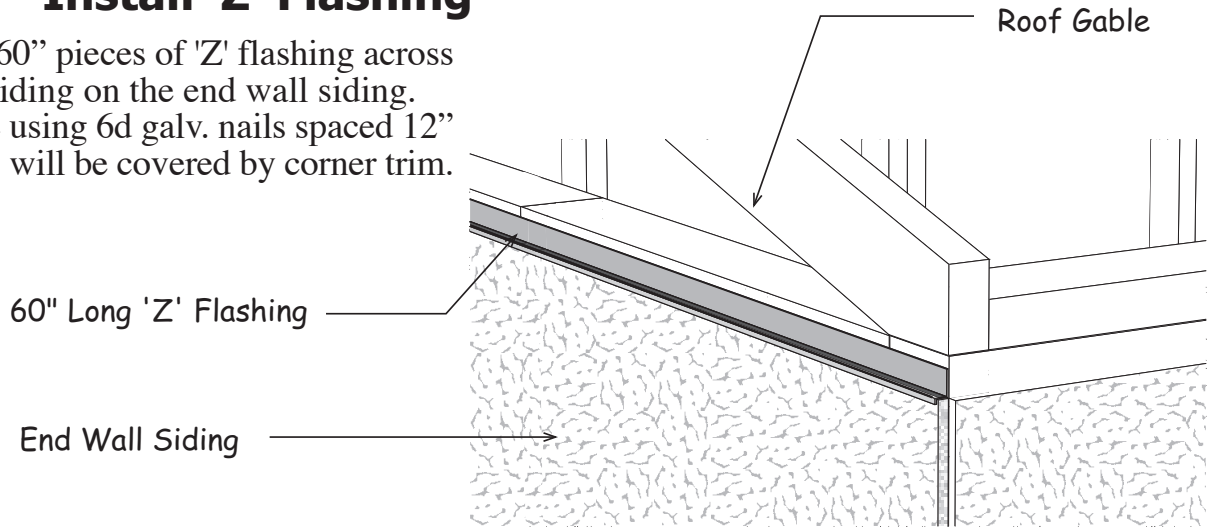

Step 11 Install Roof Gable Siding

1. Install gable siding on the roof gable using 6d galv. The gable siding should extend no more than 1/2" above the 2x4 frame and 1-1/2" past gable ends.
2. Repeat **Steps 8 thru 10** to install the opposite gable.

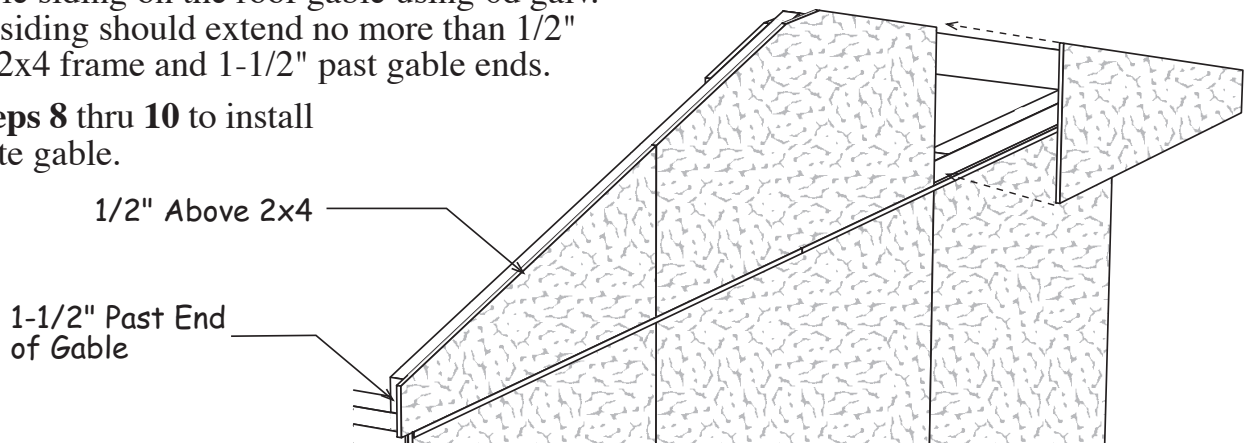

Step 12 Install 2x4 Truss Headers

1. Place a 72" long 2x4 on top of the siding on the front wall, it will butt against the siding on the roof gable. Nails this 2x4 to the 2x4 tie plate with 10d sinkers.
2. Cut to fit a 72" long 2x4 and install to finish.
3. Repeat to install 2x4s on the back wall.

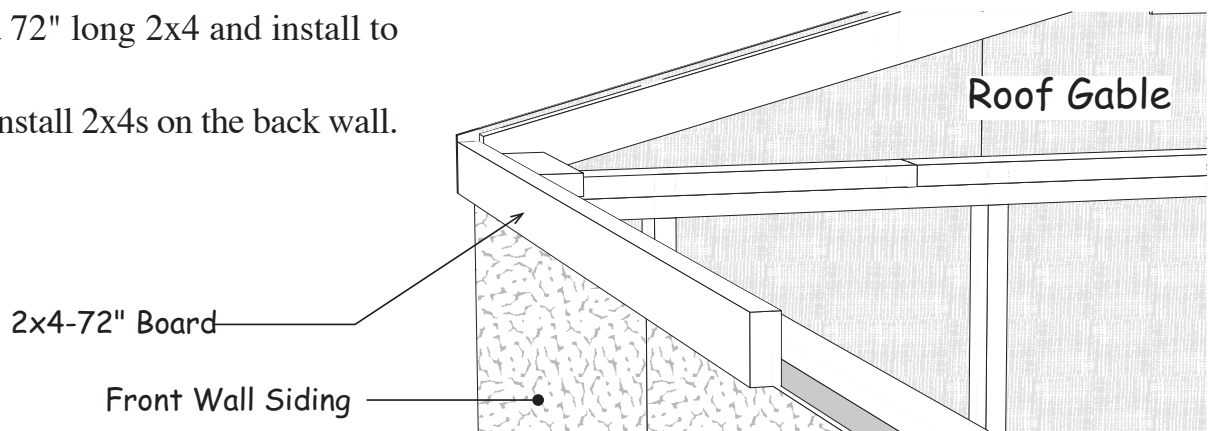

Step 13 Install Trusses

1. Starting from left end wall install the first truss measuring 21-3/4" from the face of the 2x4 on back gable and the face of 2x4 truss. Secure the trusses using 2-1/2" screws and 10d sinkers, See Detail 'A' on next page.
2. Install the remaining trusses 24" on center, *see detail below*.

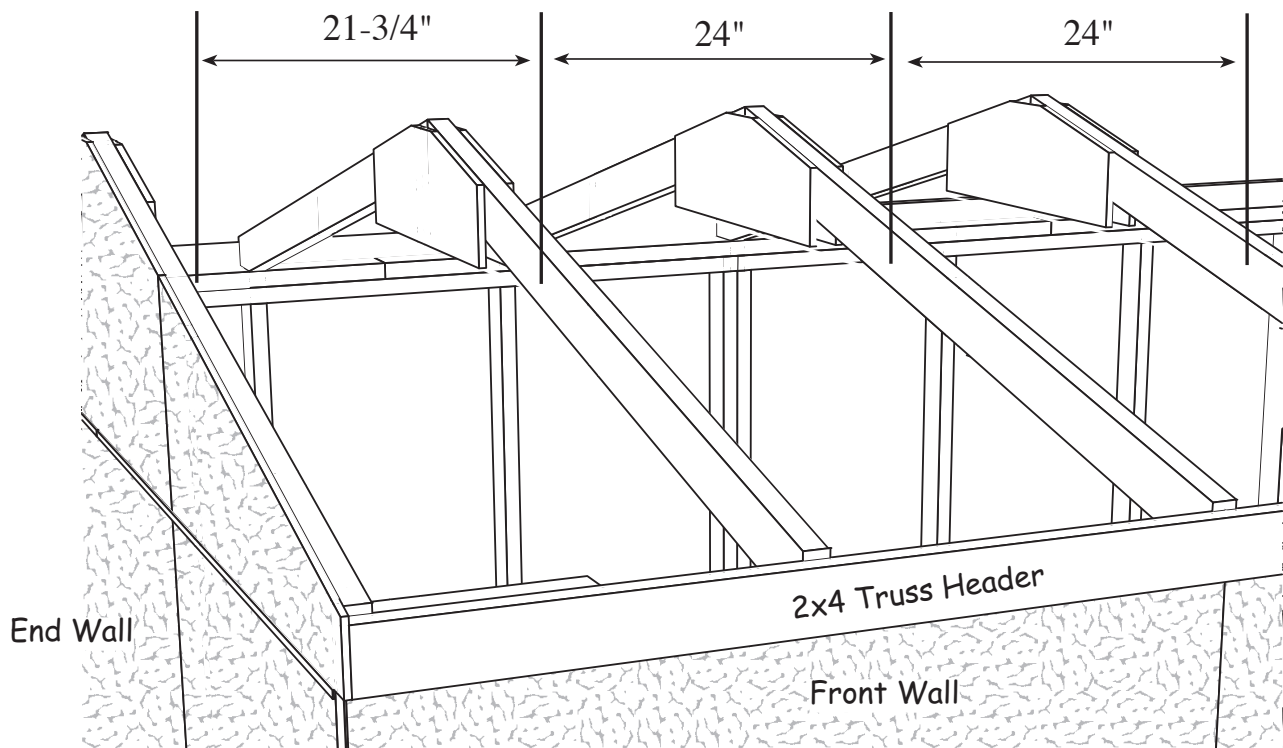

2x4" Truss Header

Detail 'A'

Using a 2-1/2" screw, secure all trusses to 2x4 Truss Header installed in Step 11. Toe nail truss into 2x4 tie plate using 10d sinkers.

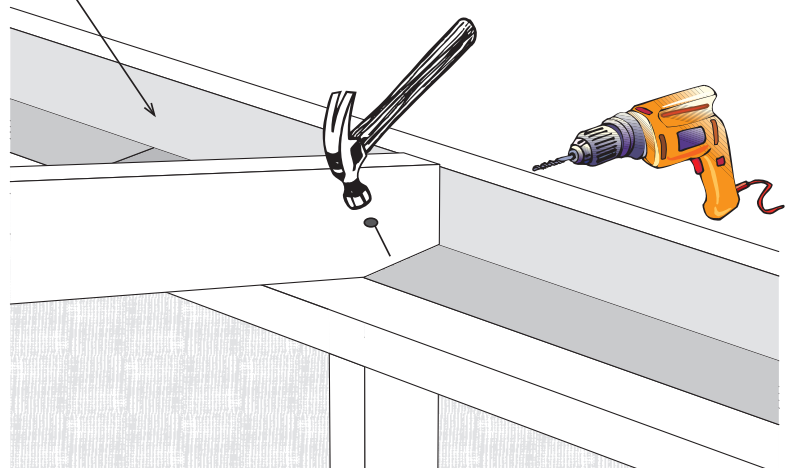

Step 14 Install 1x4 Fascia

1. Install 72" long 1x4 fascia trim over the 2x4 Truss Headers on the front wall. Install 1x4 trim boards flush with the bottom of the 2x4 and face of the siding on the gable. Use 6d galv. nails spaced 12" apart.
2. Cut a 74" long 1x4 to length and install flush with the siding on the other gable.
3. Repeat to install 1x4 fascia on the back wall.

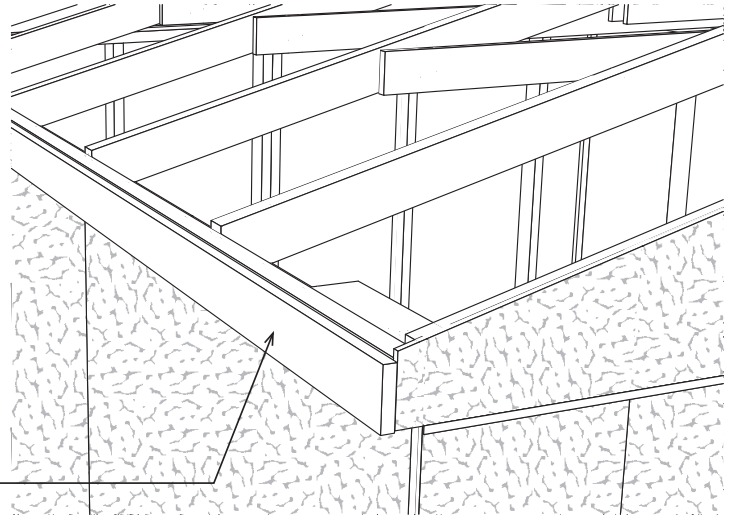

Step 15A Install Roof Sheathing

 Install roof sheathing with 6d common nails, space nails 12" apart. When installing sheathing across the top, insert a plyclip into the roof sheathing between each truss. The top row of sheathing will be about 1" below the ridge to allow for optional ridge venting. See detail next page.

1. Install a 24"x48" roof sheathing panel against the back of of gable siding. Note: Using a straight edge install the top edge of the roof sheathing flush with the face of the 1x4 fascia. See Detail 'B'.
2. Install a 48"x48" sheet next to the 24"x48" sheet.
3. Install a 15"x48" sheathing panel at the top.
4. Continue to install sheathing per layout on next page.
5. Repeat on opposite side.

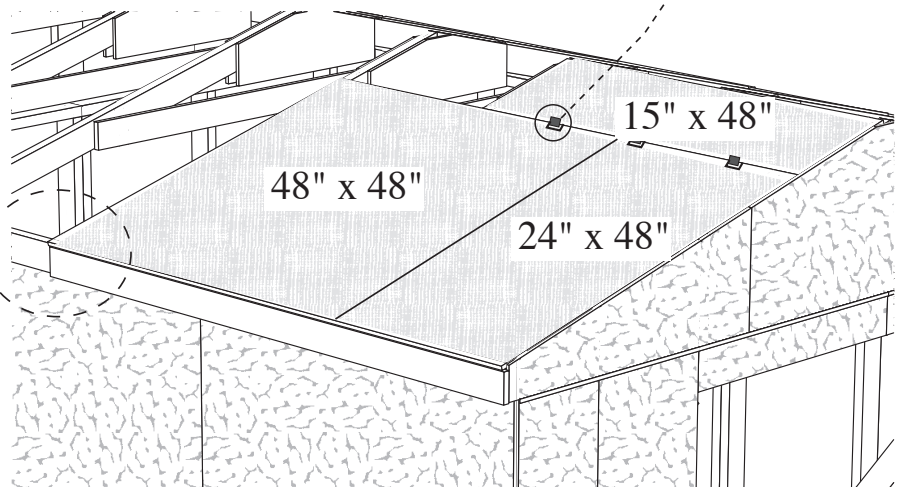
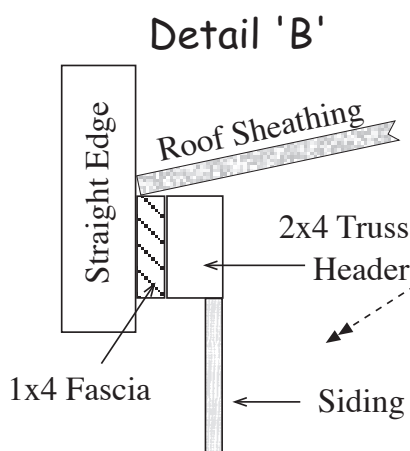
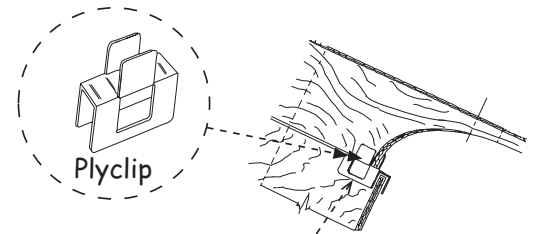

Step 15B Install Roof Sheathing Continued

Install roof sheathing on each side of the building as per pattern on right.

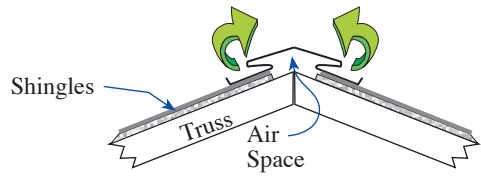

See supplier of shingles to purchase ridge venting.

Roof Ridge			
15" x 48"	15" x 48"	15" x 48"	
24"x48"	48" x 48"	48" x 48"	24"x48"

Step 16 Install Trim

1. Install 64-3/8" long 1x4 gable trim flush with the top of the roof sheathing on both end walls. Use 6d galv. nails spaced 12" apart.

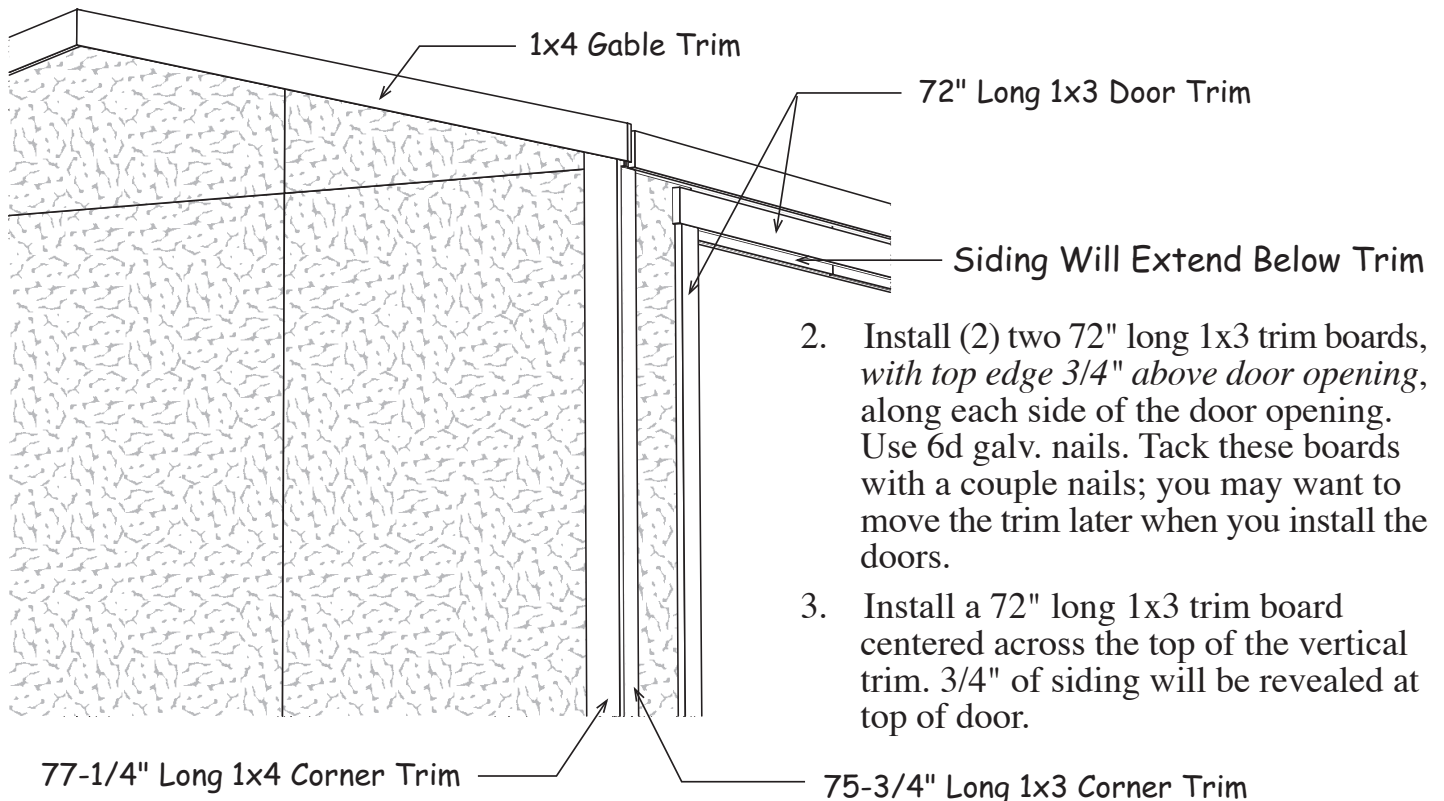

2. Install (2) two 72" long 1x3 trim boards, with top edge 3/4" above door opening, along each side of the door opening. Use 6d galv. nails. Tack these boards with a couple nails; you may want to move the trim later when you install the doors.
3. Install a 72" long 1x3 trim board centered across the top of the vertical trim. 3/4" of siding will be revealed at top of door.

4. Install 75-3/4" long 1x3 corner trim, on the front wall, flush with the face of the siding on the end walls. Repeat for back wall.
5. Install 77-1/4" long 1x4 corner trim on the end wall, flush with the face of the front wall trim. Repeat for back wall.
6. Repeat to install trim on opposite end wall.

Step 17 Install Doors & Hardware

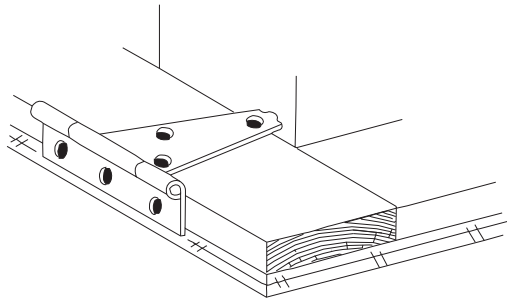

1. Lay the left door with the trim facing up. The siding on the left door extends past the door trim. See detail below.
2. Install 5" hinges to the left side of the door frame. To position the hinge properly, hold the rectangular plate against the frame. Use 1-1/4" black screws.
3. Install hinges to the right side of the other door.

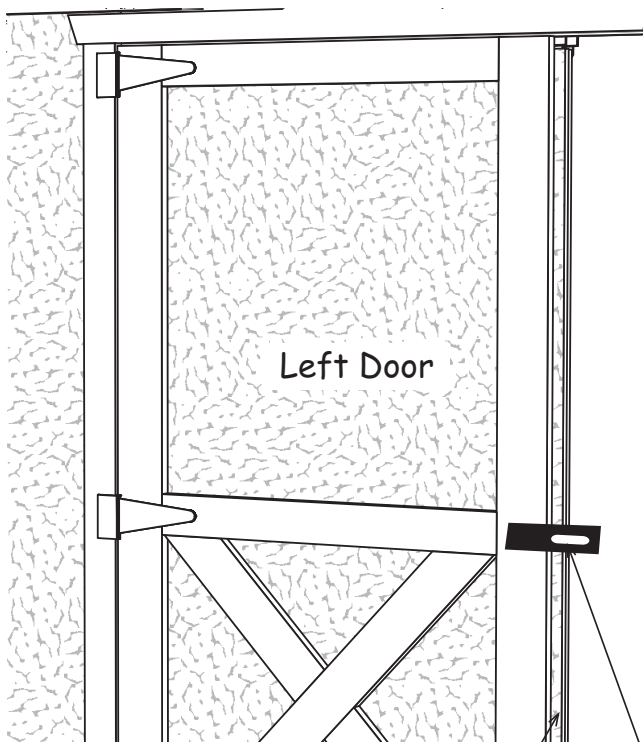

4. Before fastening the hinges to the side trim, temporarily prop the doors in the opening. Leave a space at the top and bottom of the doors and between the doors and the side trim to allow room for the doors to expand due to humidity.

If your door opening is out of square, the space around the doors will not be even. You can remove and re-position the side trim to make allowances for this. The side trim does not have to be flush with the frame of the door opening. You can move the trim in or out to make the door spacing equal.

5. Determine position of hinges and install to side trim with 2" screws.
6. Install door hasp on double doors. When properly installed the hasp will fold in half to receive locking latch and the screw heads will be covered.

Siding Extends Past Trim

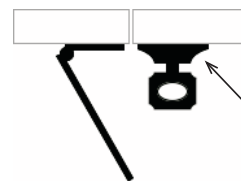

Fold Hasp to Cover Screws

Barrel Bolt on the back of left door

7. Install a barrel bolt on the lower back of the door to secure this door in place when closed. You will need to drill a hole for the round shaft to drop into.
8. Install another barrel bolt at the top of the door.

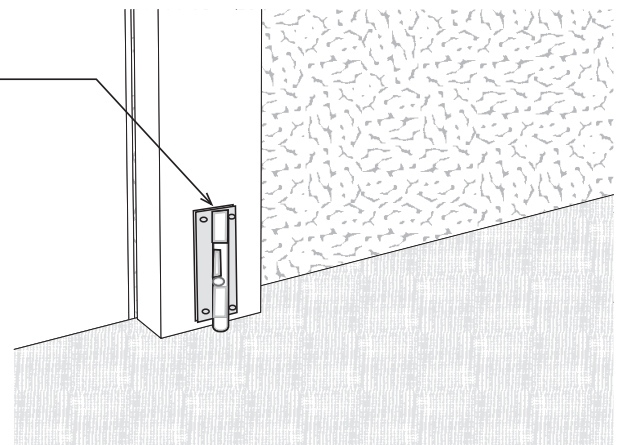

10'x12' Packing List

Qty.	Description		
14	2x4	62"	Truss Rafters
41	2x4	72"	Studs & Plate Boards
8	2x4	68-1/2"	Plate Boards
10	2x4	60"	Plate Boards
6	2x4	10"-12"	Blocks for Truss Jig
2	2x4	67-1/2"	Door Header
4	1x4	64-3/8"	Gable Trim
4	1x4	77-1/4"	Corner Trim
4	1x3	75-3/4"	Corner Trim
3	1x3	72"	Door Trim
2	1x4	74"	Fascia Trim
2	1x4	72"	Fascia Trim
2			Pre-built Barn Doors
7	48"x75-3/4"		Primed Wall Siding
2	36"x75-3/4"		Primed Wall Siding
2	16"x75-3/4"		Primed Wall Siding
2	12-1/2"x75-3/4"		Primed Wall Siding
2	4-3/4"x32-1/4"		Primed Wall Siding
2	48"x19-3/4"		Primed Gable Siding
4	38"x14-1/4"		Primed Gable Siding
4	48"x48"		OSB Roof Sheathing
4	24"x48"		OSB Roof Sheathing
6	15"x48"		OSB Roof Sheathing
1	3-1/2"x67-1/4"		Header Filler
12	8"x24"		OSB Wood Gussets

Qty.	Hardware Description		
3	lbs.	10d	Coated Sinkers
3	lbs.	6d	Galvanized Nails
3	lbs.	6d	Common Nails
6		5"	Hinges
1		4"	Door Hasp
2		6"	Barrel Bolts
25		1-1/4"	Hinge Screws
25		2"	Hinge Screws
50		2-1/2"	Deck Screws
18		7/16"	Ply-clips
16		3/4"	Pan Head Screws
4		60"	'Z' Flashing

Roofing Material Purchased By Owner

5 bdl. Roof Shingles 6 pcs. Roof 'drip' edge