

Obtaining a permit for your Best Barns shed or garage kits

*Do-it-Yourself kits from Best Barns are designed for use as storage buildings or garages only. Use for any other purposes is neither implied nor inferred.**

Building code offices and HOA's may require additional documents to obtain a permit. The homeowner's first step is to contact their local code office and ask what is needed for the size of building to be purchased.

Typically, the necessary documentation may include some or all of the following.

- o Elevations showing at least two sides of structure.
- o Site plan showing existing structures and proposed build site.
- o Engineered drawings for truss system indicating snow and wind load ratings.**
- o Cross sections of wall framing and foundation.
- o Tie down locations for high wind load areas.***

Permit requirements vary based on location. Some areas may not require a permit at all. The documents provided by Best Barns are intended to help the homeowner with the permit process but do not guarantee a permit will be issued. It is the homeowner's responsibility to determine if a permit is required and submit the necessary documentation.

*Any alteration to the construction of Best Barns sheds or garages may require the services of a civil engineer to meet local building codes. Best Barns cannot provide these additional services.

** Engineered truss drawings stamped for your individual state can be obtained upon request. Some models do not have wind and snow load ratings. A deposit will be required if the shed or garage kit has not yet been purchased. Contact us directly at 800-245-1577 for further details.

*** Certain states such as Florida and California have stringent requirements for obtaining a permit. Depending on your location, a civil engineer's services may be required to provide necessary documents. These services are the homeowner's responsibility to obtain and are not included in the purchase of a shed or garage kit.



Before you order our kit or begin construction, obtain a building permit. If additional documents are required contact questions@barnkits.com.

Dover Elevations

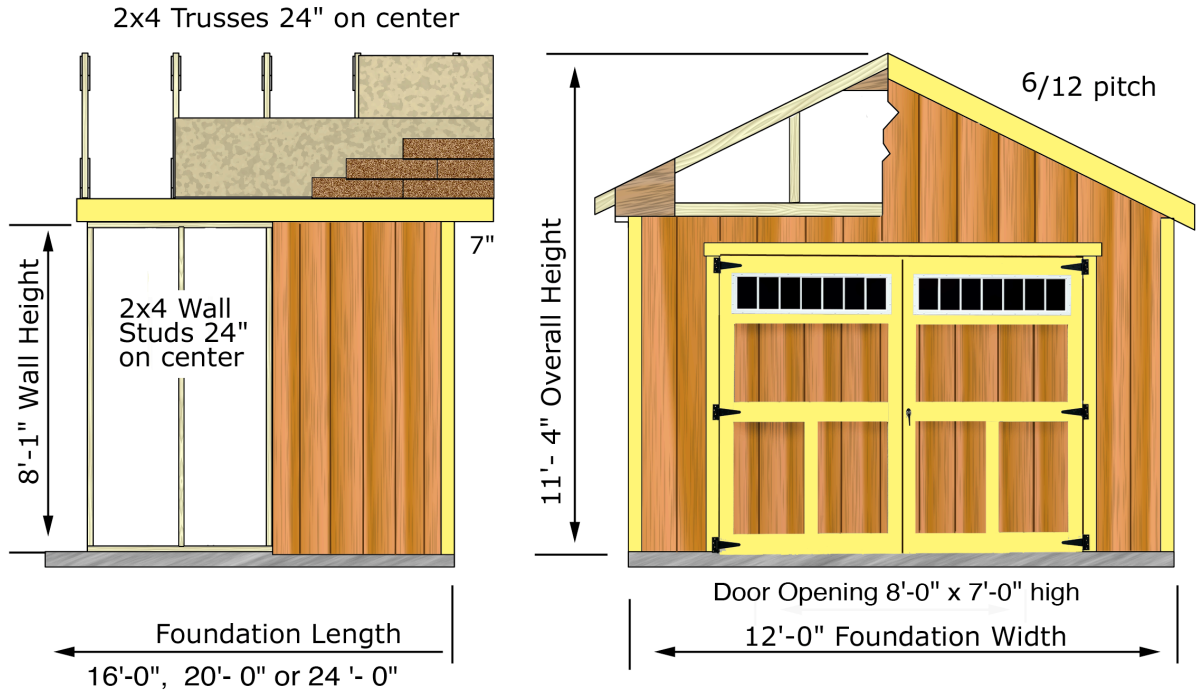

Floor: Sold optionally

Wall Framing: 2x4 Construction with 24" on center stud spacing, with top wall plate and tie plates and single treated bottom plate.

Siding: Louisiana-Pacific 8" o.c. groove 'Smart Panel' primed with 50 year warranty, 5 year labor replacement.

Roof System: 2x4 trusses spaced 24" on center, (see engineered truss drawing for load ratings). 7/16" OSB roof sheathing. *Shingles by owner.*

Primed Trim: White pine trim for gables, perimeter of door opening, exterior corners and side wall fascia.

Pre-Built Doors: Pre-built doors with a 2x4 frame covered with LP 'Smart Panel' siding. Primed white pine trim installed over siding. Two transom windows. Lockable door handle with key, heavy duty 6" door hinges and barrel bolts to secure doors when closed.

Hardware: Nails for wall framing and trim, metal hurricane hangers for trusses included.

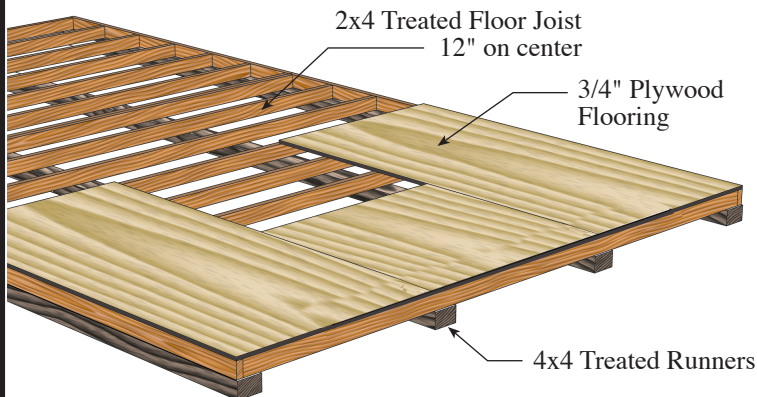

Optional Sturdy-built Floor System:

2x4 treated floor joist spaced 12" on center covered with 3/4" plywood, *not treated*, installed over 4x4 treated runners.

12'x16' Foundation Size	12'-0" x 16'-0"
12'x20' Foundation Size	12'-0" x 20'-0"
12'x24' Foundation Size	12'-0" x 24'-0"

Best Barns model: _____
____ ft. wide x ____ ft. long

Manufactured by:
Reynolds Building Systems, Inc.
205 Arlington Drive
Greenville, PA 16125
phone: 800-245-1577
fax: 724-646-0772

Common Foundation Cross Sections

This document illustrates common foundation types which can be used for construction of Best Barns 12 ft. wide structures. Alteration may be necessary to conform to homeowners intended use and or permitting requirements.

Drawings not to scale.

Instructions:

Check appropriate foundation cross section and provide specifications as necessary.

Homeowner may also design and draw in space provided for custom foundation type.

Concrete Slab

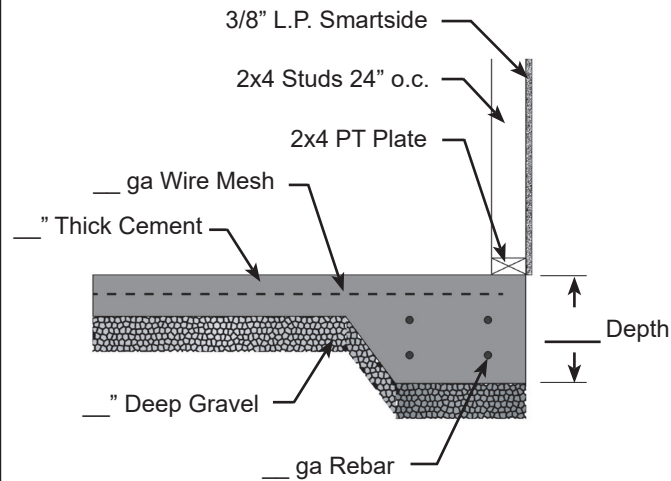

Wood Floor

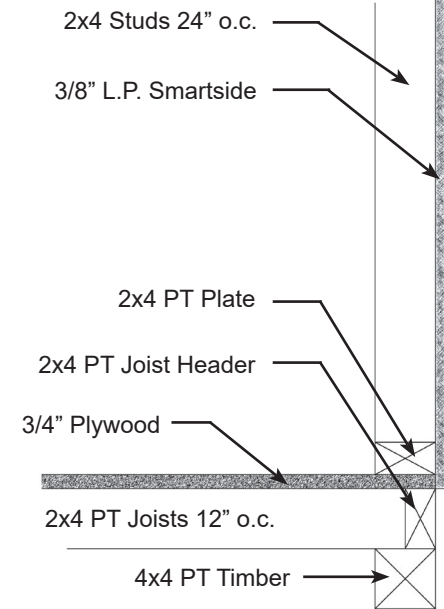

Homeowner Design

Best Barns model: _____
____ ft. wide x ____ ft. long

Manufactured by:
Reynolds Building Systems, Inc.
205 Arlington Drive
Greenville, PA 16125
phone: 800-245-1577
fax: 724-646-0772

Truss & Wall Cross Section

Top of wall inclusive of wall
framing and truss cross sections.

Drawing not to scale.

Instructions:

Homeowner may provide
additional information as
appropriate.

Notes:

Refer to installation manual for
further detail.

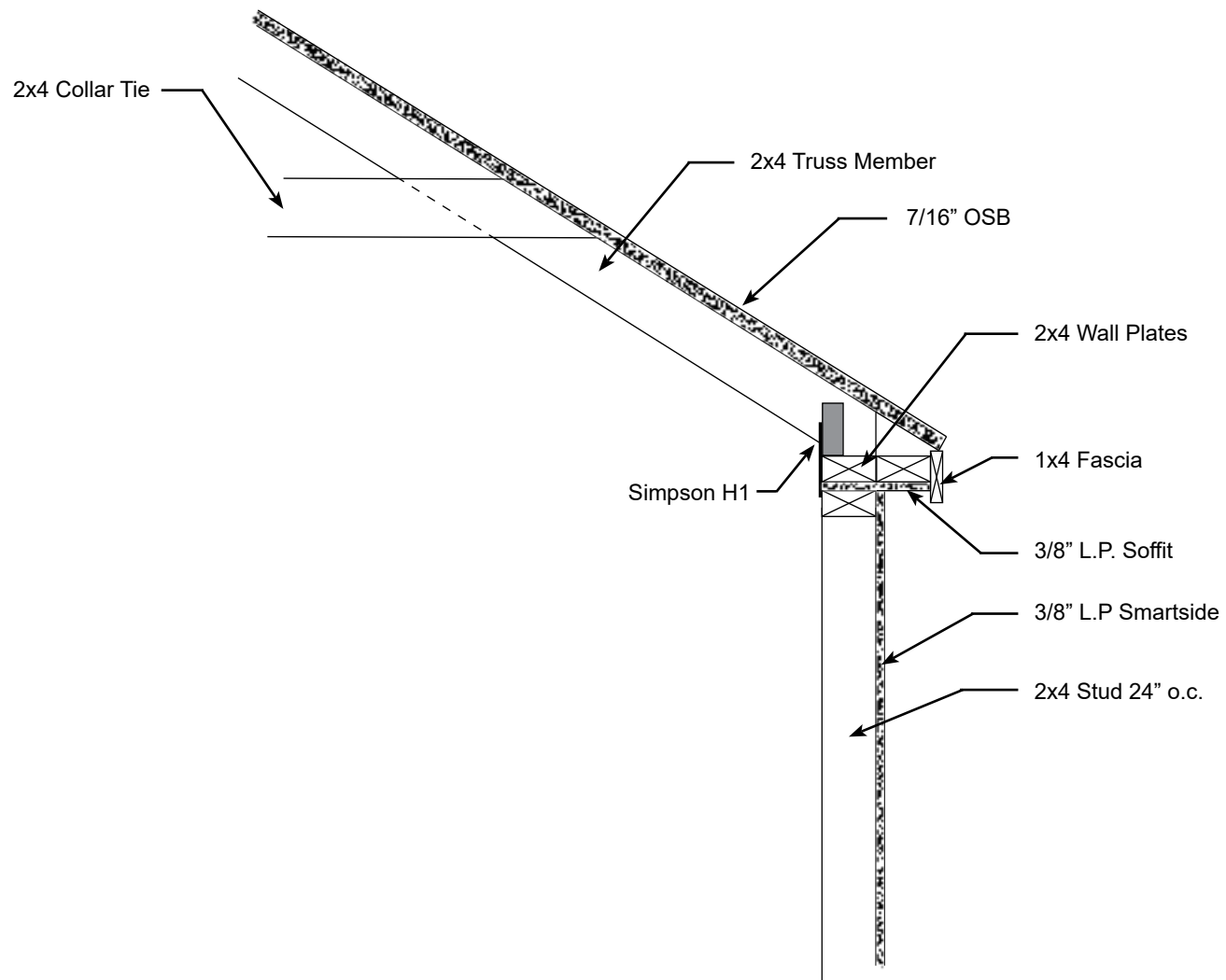

Site Plan for:

Manufactured by:
Reynolds Building Systems, Inc.
205 Arlington Drive
Greenville, PA 16125
phone: 800-245-1577
fax: 724-646-0772

Instructions:

Draw property line, existing structures and proposed placement of building.

Homeowner may also be required to show trees and shrubs. Check with HOA or permit office for requirements.

A large, empty rectangular box with a black border, intended for the site plan drawing. It occupies the right two-thirds of the page.