



Assembly Book

Revised on April 19, 2018



Northwood Deluxe 10'x10'

Manufactured by Reynolds Building Systems, Inc.

205 Arlington Drive Greenville PA, 16125

This manual is copyrighted. Under the copyright laws, this manual may not be copied, in whole or in part, without consent from Reynolds Building Systems, Inc. © Copyright 2011

IMPORTANT INFORMATION ABOUT YOUR SHED KIT

Thank you for purchasing our shed kit. These instructions will construct a 10'x10' building. **If you received two books, use the one with the latest revision date.**

Read the instructions before starting the assembly of the building. If you have any questions about assembling the kit, call 800-245-1577. Business hours (8:00-5:00 ET) Monday thru Friday. After business hours call 724-866-HELP (4357) or email to help@barnkits.com.

The material that is included in our kit is listed on the back page. The optional floor package, if purchased, will be supplied by a local lumber supplier.

Our kit does not include the shingles, the quantity needed is listed on the next page. The siding is primed. You will need to apply a finish coat using latex acrylic paint.

Some of the framing lumber was used in the shipping pallet. Unpack the material from the pallets, then unscrew the bottom runners from the 2x4s. The bit for the screws is packed in the hardware bag. This material will be used for wall bracing and tie plates.

Most buildings are installed on a wood floor and the siding was designed to extend over the wood flooring. If you are installing the building on a concrete slab cut the siding flush with the bottom wall plate. Install sill sealer between the bottom plate and the concrete slab. This material will protect the 2x4 bottom plate from moisture and chemicals in the concrete.

Stacking the boards, according to size, will make them easier to find when needed. Some boards have colored ends. All the wall studs have black ends, stack these boards together. **Do Not** discard any material until your building is complete.

Before you begin construction, be sure to study this assembly manual. Also, obtain a building permit and check all pertinent building code regulations.

Thank you for your purchase.

Bill & Linda Rinella, owners

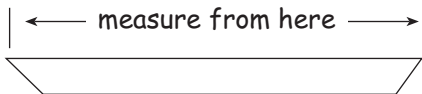

When measurements are given for a board length, it is along the longest side.

Tool List

- | | |
|--|---|
| <input type="checkbox"/> Hammer & Phillips Screwdriver | <input type="checkbox"/> Electric Drill/Screwdriver |
| <input type="checkbox"/> Framing Square & Level | <input type="checkbox"/> Measuring Tape |
| <input type="checkbox"/> Hand Saw/circular saw | <input type="checkbox"/> 2-8' Step Ladders |

Always wear safety glasses when cutting or nailing!

Material Purchased Locally				
10'x10' Building	6 bdl.	Roof Shingles	6 pcs.	Roof 'drip' edge
14'x10' Building	8 bdl.	Roof Shingles	7 pcs.	Roof 'drip' edge

General Construction Guidelines

Siding is made in sheets with grooves cut into the face, the long edge is beveled so that the siding overlays where they butt. This serves to hide where the panels join together and gives the appearance of one continuous piece of siding.

To identify which edge we want you to use, we will refer to the edge as either the 'LAP' Edge or the Tongue Edge.

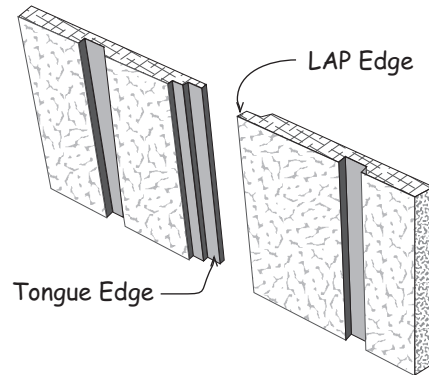

Be sure the wall frame is square. Measure the wall diagonally (corner to corner). Then measure the opposite corner. The measurements will be the same, if the wall is square.

Position all the siding panels on wall frame, tacking siding in place. When the siding panels are adjusted to fit properly, nail siding in position using 8d galv. nails. Space nails 9" apart.

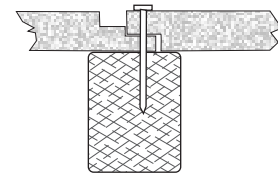

Paint the bottom edges of the siding around the perimeter of the building. Keep dirt, grass, mulch and snow away from the lower part of the siding. The siding manufacturer recommends 8" or more of clear space.

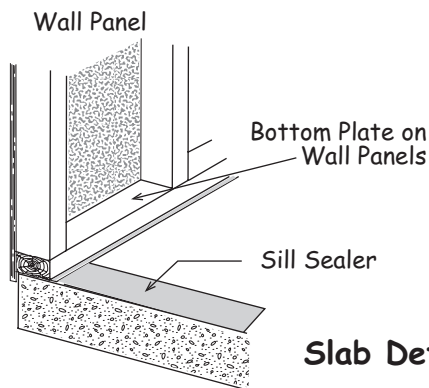

Slab Detail

Foundation Information

When using a concrete slab for a floor, install foam sill sealer as a moisture barrier between the concrete and the bottom wall plate.

Constructing Details for Deluxe Floor System

Deluxe floors include 4x4 runners, standard floors do not

Check local building codes in your area, the construction may have to change. For a concrete slab, install sill sealer as a moisture barrier between the concrete and the wall plates. Foam sill sealer can be purchased at home centers in rolls 3-1/2" or wider.

1. Cut joist headers to floor length. See Below.
Layout for 16" on center joist spacing. 'X' marks where floor joist will be placed.

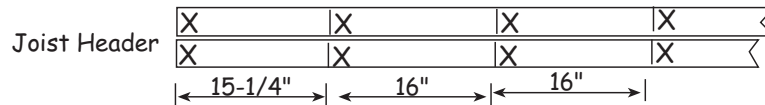

2. Cut 2x4-10' floor joists to 9'-9". *Treated lumber may be thicker than 1-1/2". Take this into account when cutting the length of floor joists. Shorten joist measurements if necessary to obtain 10'-0" building width.*

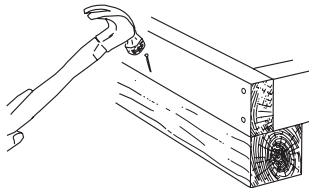
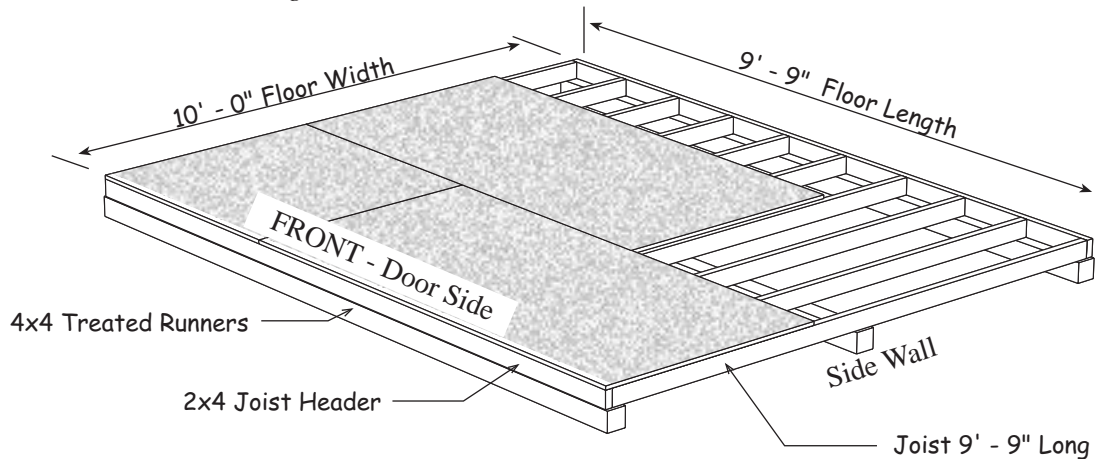

Nail 2x4 joist headers and floor joist to 4x4.

It is important that the floor be level and square. Before nailing the flooring, measure the floor diagonally (corner to corner). Then measure the opposite corners. These measurements will be the same if the floor is square.

If installing building on a concrete slab, install sill sealer between concrete and bottom wall plate.

Material Description	10' x 10' shed
2x4 Joist Headers	2 pcs. 10'
2x4 Floor Joist	9 pcs. 10'
4x4 Treated Runners	3 pcs. 10'
Flooring 5/8" or 3/4"	4 pcs. 4x8
Screw Floor Nails	1 lb. 8d
Galv. Box Nails	1 lb. 16d

Step 1 Assemble Trusses

 **Building Tip:** To aid in the assembly of the trusses, temporarily tack 2x4 blocks to the floor. There are short 2x4s, *that may have an angle on one end*, supplied in the kit for this purpose. This will trap the truss parts and insure that all the trusses will be assembled the same.

1. Position a 138" long 2x4 and (2) two 79-5/8" long 2x4s diagonally across the floor. The shorter 2x4s will rest on a flat spot on the bottom 2x4. *See Detail 'A' below.*
2. Affix 2x4 blocks around the truss members to hold them in place. Tack a 3" wide gauge block, *in hardware bag*, at both ends of the bottom 2x4 to maintain the correct overhang.
3. Secure the tops together with a wood gusset. Apply wood glue between the 2x4 boards and the gusset. Nail the gusset to the 2x4s with 6d common nails. Use 14 nails per gusset.
4. Install 12"x12" wood gussets to the ends of the trusses, flush with the end of the bottom 2x4. Glue and nail the gusset. Use 8 nails per gusset.
5. Turn this truss over and apply wood gussets to the opposite side.
6. Assemble (3) more trusses.

Do Not remove blocks from floor until completing **Step 2**.

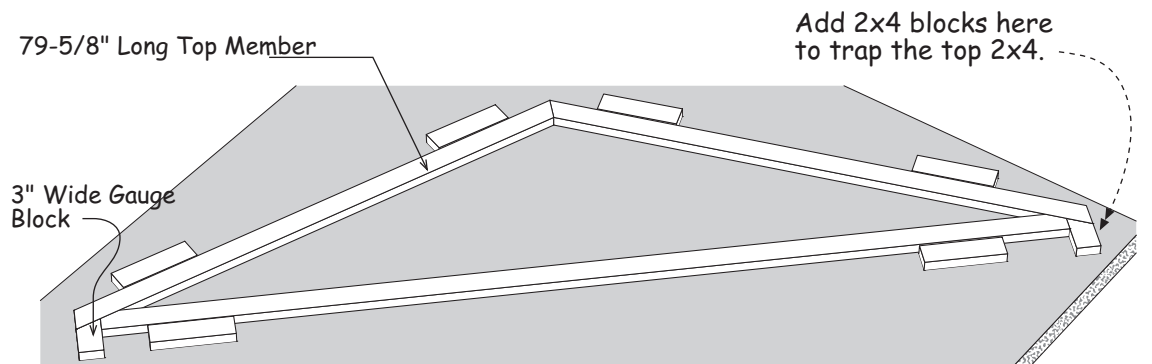

DETAIL 'A'

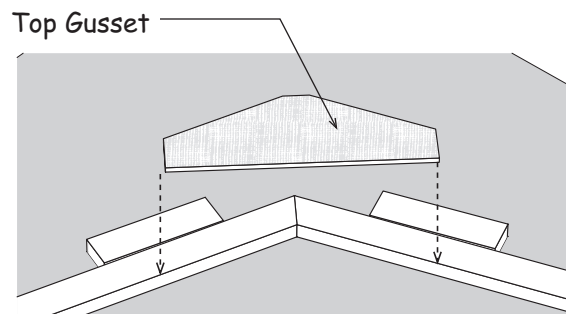
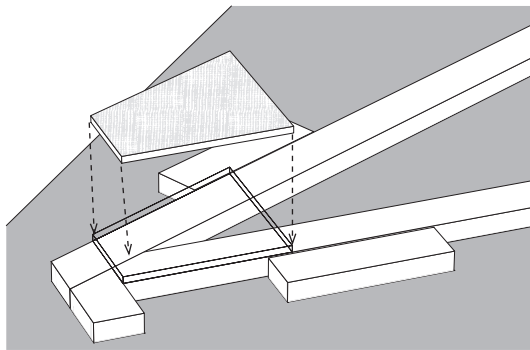

Step 2 Assemble Roof Gables

1. Use the remaining truss parts to assemble the roof gables. Position 2x4s between the blocks.
2. Place (2) two 20-3/4" long gable studs between the top and bottom 2x4s. The siding will secure them in place.

20-3/4" Gable Studs

138" Bottom Plate

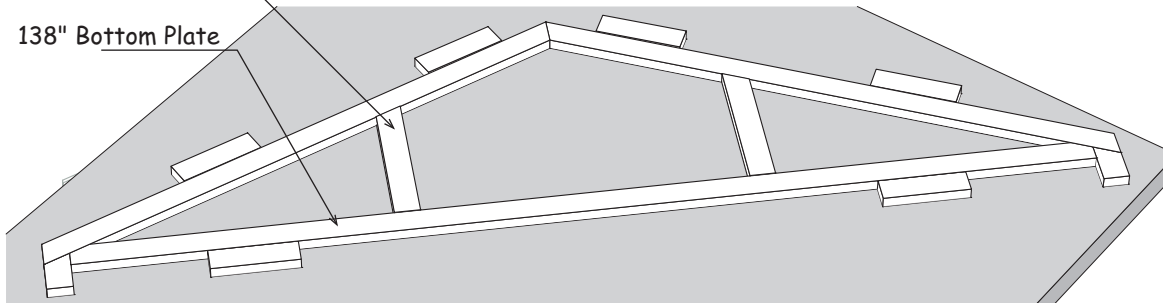

3. Lay gable siding over the gable frame. The siding should extend 3/4" below the lower 2x4.
4. Nail siding to the frame with 6d galv. nails.

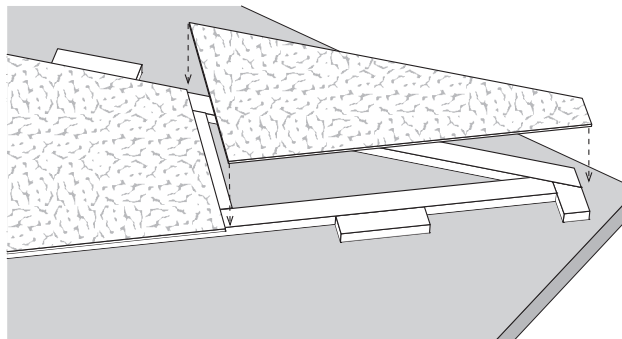

5. Turn gable frame over and install 18" long 2x4 blocks to the bottom of the gable frame. Install blocks 21" from each end and one in the center. Use 2-1/2" long screws.

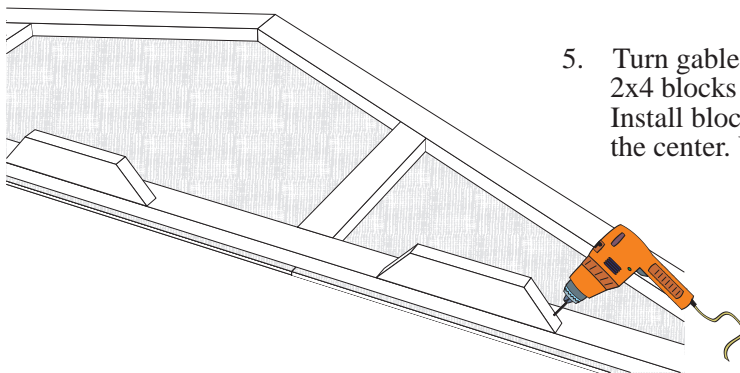

6. Repeat steps to assemble another roof gable.

Step 3 Assemble Back Wall

1. Locate (2) two 2x4 boards 68-1/2" long [**green ends**] and (2) two boards 41-1/2" in length. Position these boards together and indicate with 'X' marks, where the wall studs will be located.

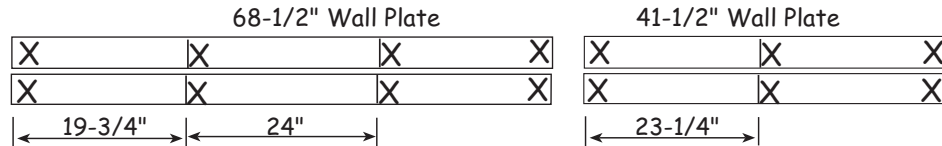

2. Install 72" wall studs [**black ends**] between the top and bottom plates. Assemble the frames with 10d sinkers, two nails per stud. Nail both wall frames together.
3. Install 45" and 72" long 2x4s as tie plates over the top plate. The 2x4 tie plates will extend 3-1/2" beyond the wall frame.

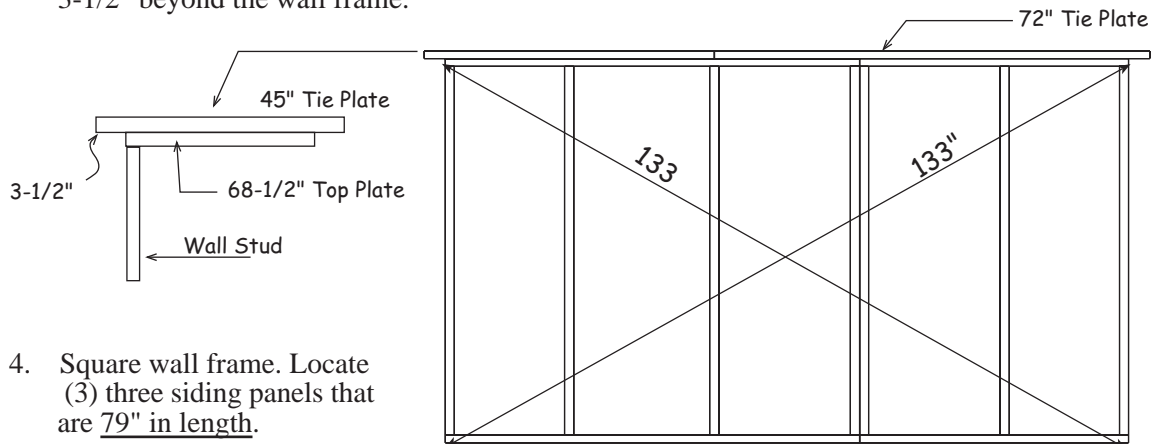

4. Square wall frame. Locate (3) three siding panels that are 79" in length.
5. Install the first panel with the 'LAP' edge flush with the end of the 2x4 tie plate. The siding should extend 3/4" below the bottom plate. The siding will extend above the top 2x4. Use 8d galv. nails. Space nails 12" apart.
6. Install another siding panel. Install a 20-3/4" wide siding panel flush with the end of the 2x4 tie plate. The siding will extend 3-1/2" beyond the wall frame.

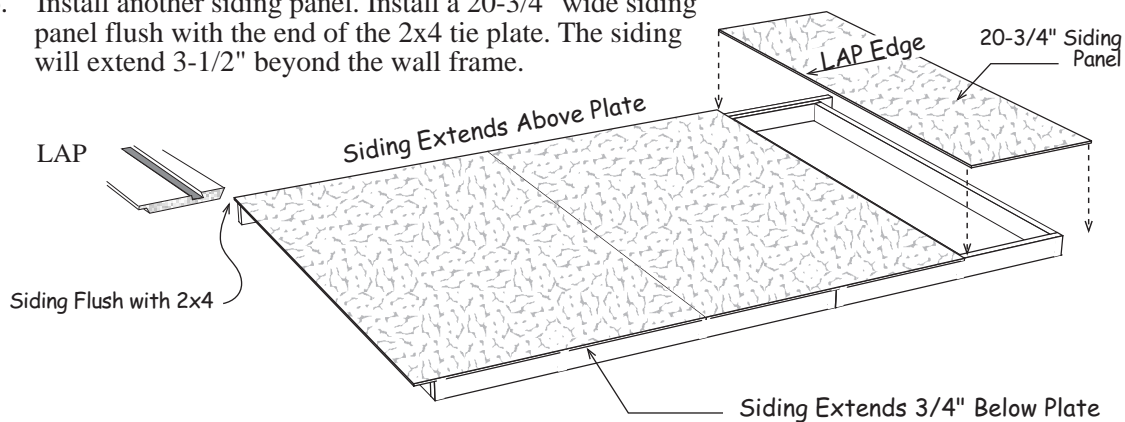

Step 4 Assemble Left Sidewall

1. Locate (2) two 2x4 boards 69" long and (2) two boards 51" in length. Position these boards together and indicate with 'X' marks where the wall studs will be located.

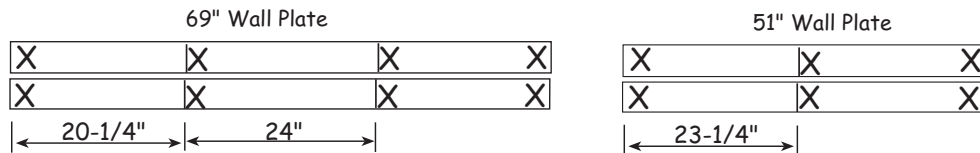

2. Install 72" wall studs between the top and bottom plates. Nail both wall frames together.
3. Locate the 2x4s removed from the shipping pallet. Cut (2) two of the 2x4s to a length of 74". Select another 2x4 and cut (2) two 39" long 2x4s. Save the other 2x4 for wall bracing.
4. Install 39" and 74" long 2x4s as tie plates over the top plate. The 2x4 tie plates will set back 3-1/2" from the end of the wall frame.

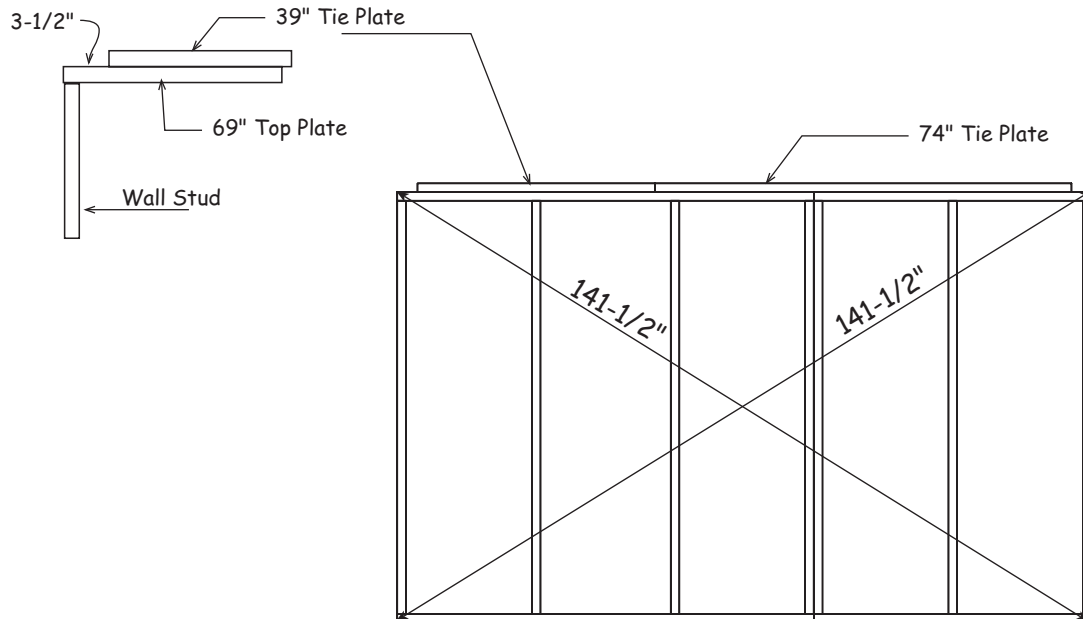

Step 4 Assemble Left Sidewall Continued

4. Square wall frame. Install a 45-3/4" siding panel, *with cut edge*, at the end of the wall and extending 3/4" below the bottom plate.
5. Install a full width siding panel.
6. Install a 27" wide siding panel last.

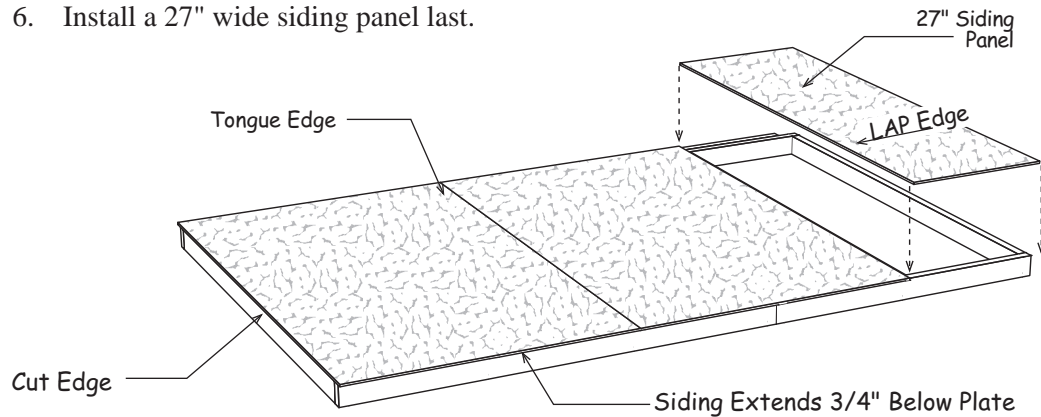

Step 5 Assemble Right Sidewall

1. Repeat **Step 4** to assemble the other sidewall. Before applying siding, turn the wall over so the 51" frame is on the left.
2. Install a 27-3/4" siding panel, *with tongue edge*, flush with the end of the wall and extending 3/4" below the bottom plate.
3. Install a full width siding panel.
4. Install a 45" wide siding panel last.

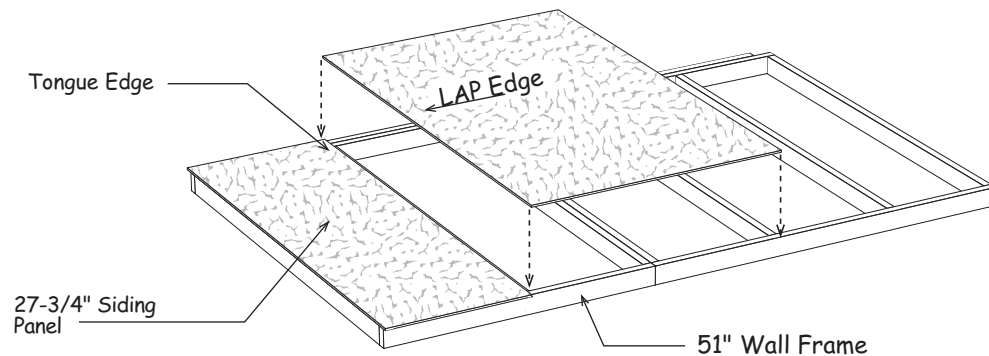

Step 6 Assemble Door Walls

1. Gather (5) five 72" wall studs, (2) two 31-3/4" and (2) two 10-3/4" long 2x4 wall plates [**coded A**]. Assemble these 2x4s using 10d sinkers.
2. Install 71-1/2" long 2x4s [**red ends**], as header supports, on each wall frame.

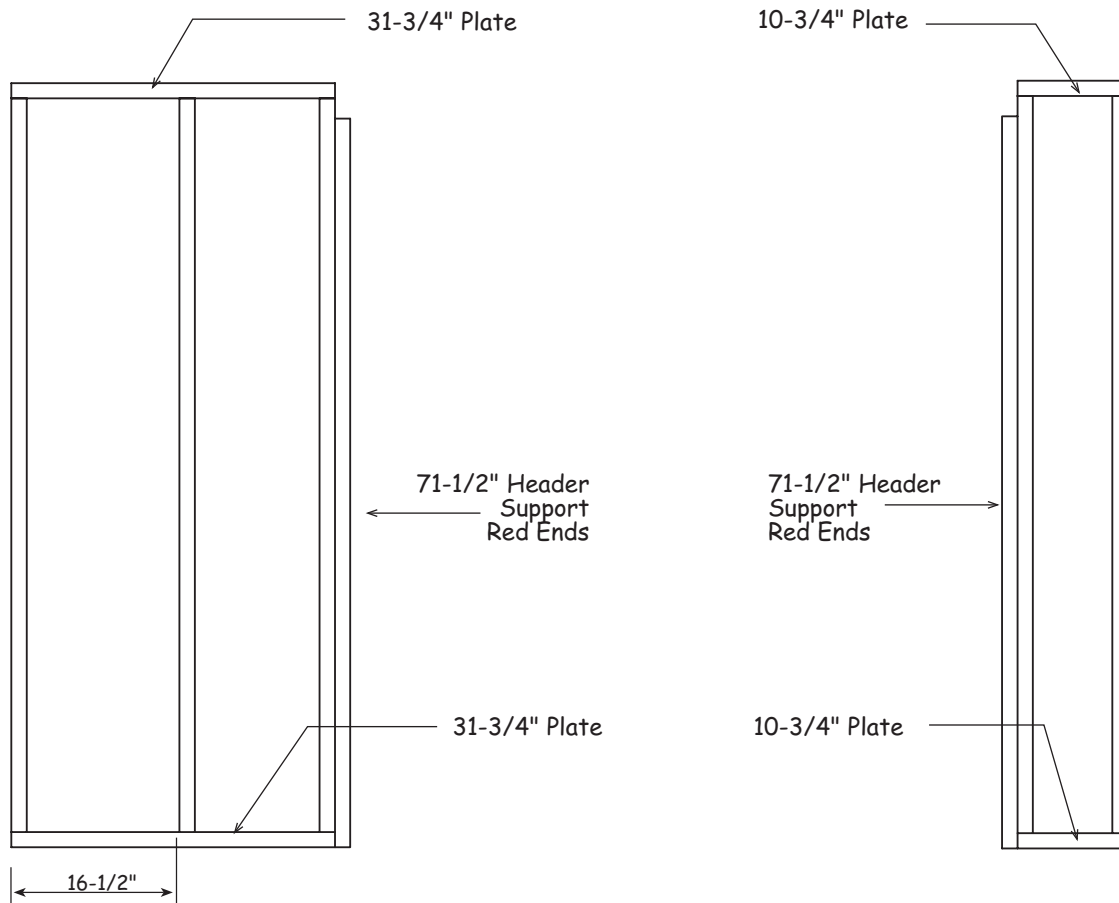

Step 7 Assemble Door Wall

 *If you want the door opening on the left, flip the walls and apply siding to the opposite side of the wall frames.*

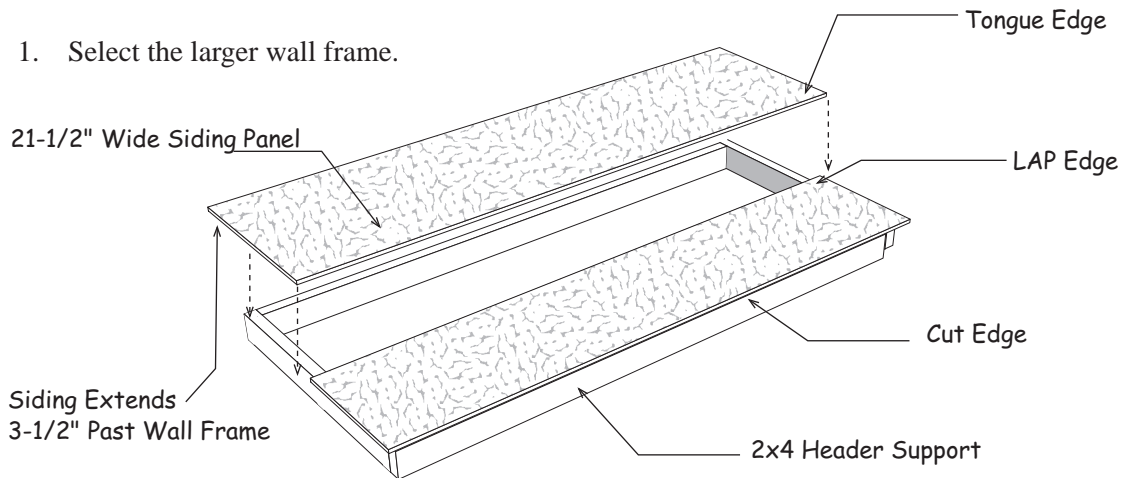

2. Locate a pre-cut 16" wide siding panel that has a 'LAP' edge. Position this panel with the 'cut' edge flush with the 2x4 header support and extending 3/4" below the bottom plate. Do not nail along the LAP edge until the other siding panel is installed.
3. Install a 21-1/2" wide siding panel. The siding will extend 3-1/2" beyond the wall frame.
4. Install a pre-cut 16" wide siding panel with the 'cut' edge flush with the 2x4 header support. The siding will extend 3-1/2" beyond the wall frame and 3/4" below the bottom plate.

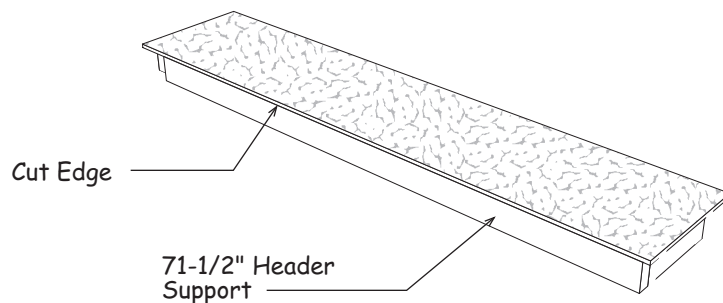

Step 8 Set Lower Walls

1. Secure wall panels together at the corners. Use (4) four 10d coated nails per corner. Nail wall panels to the floor. Nail through the bottom plate. Space 10d sinkers 24" apart.
2. Install the 2x4 door header between the front wall panels. The siding extends 1-1/2" above the top of the door header to receive 2x4 tie plate. Nail through the wall stud into the ends of the header. Toenail into the top wall plates. Wall trim, installed later, will hide where the siding butts the front wall panels.
3. Install a 2x4-7' board (from shipping pallet) at the door opening to hold the wall straight.

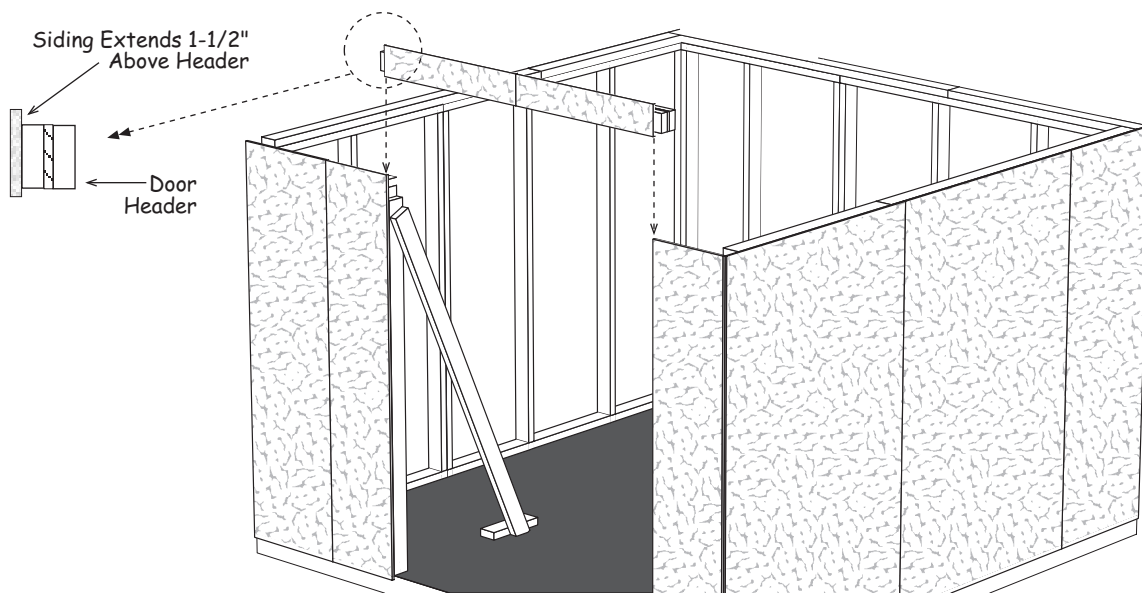

4. Install a 45" and 72" long 2x4s across the top of the front wall as tie plates. Use 10 d sinkers

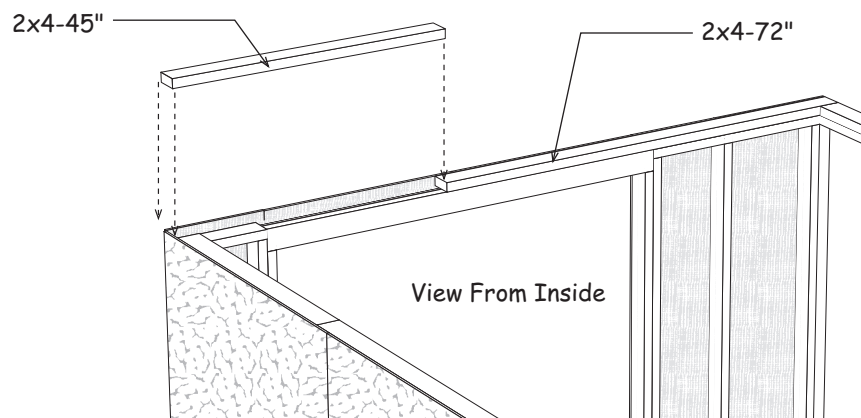

Step 9 Install Trim

 Use 8d galv. nails when installing trim.

1. Install 1x3x72" trim boards along each side of the door opening. Tack these boards with a couple nails; you may want to move the trim later when you install the doors.
2. Install a 1x3x71-3/4" board, *that has angle cuts on both ends*, over the door opening.
3. Install 1x4x77-1/4" trim boards at the front and rear corners of the sidewall. Install the trim flush with face of the siding on the front and back walls.
4. Install a 1x4x58-1/2" trim board flush with the top of the sidewall. Cut another 58-1/2" long trim board to fit.

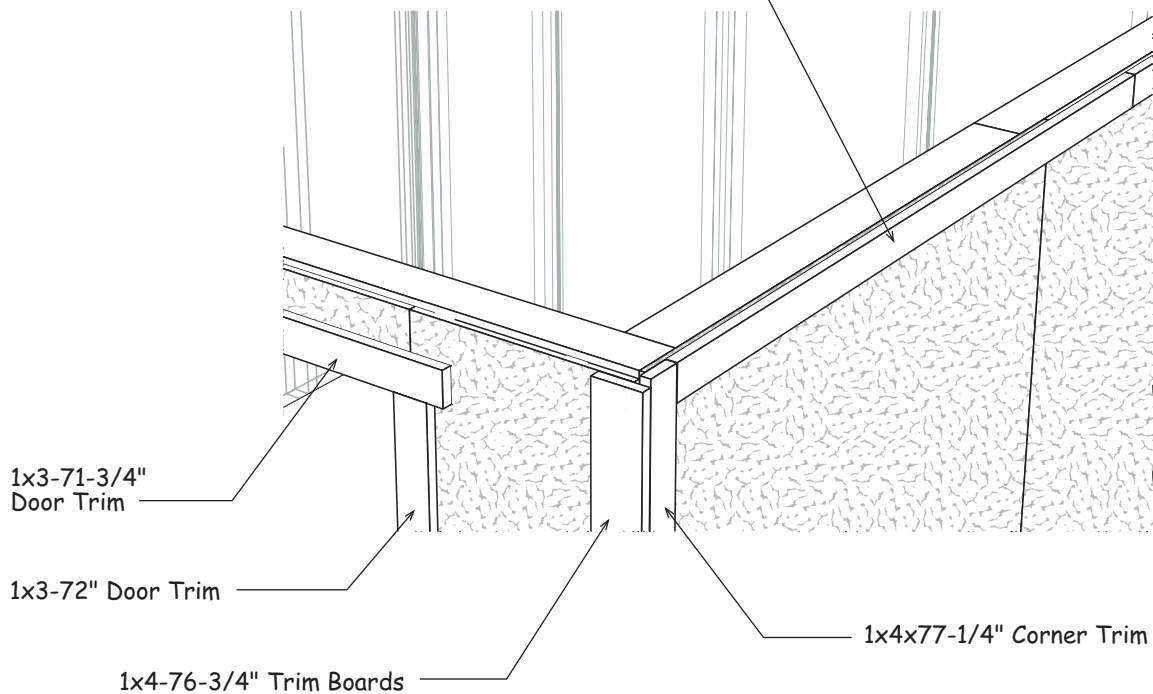

5. Install trim on the opposite sidewall.
6. Install 1x4x76-3/4" corner trim at the front corners. Install 1x4 flush with the bottom of the siding on the front wall.

Step 10 Install Gable on Right Sidewall

1. Install the gable on the right sidewall. The gable siding will extend over the 1x4 trim on the lower wall. Secure gable to wall by nailing through the gable blocks with 10d sinkers.
2. Nail siding along the 1x4 trim board with 6d galv. nails.
3. Install the left gable.

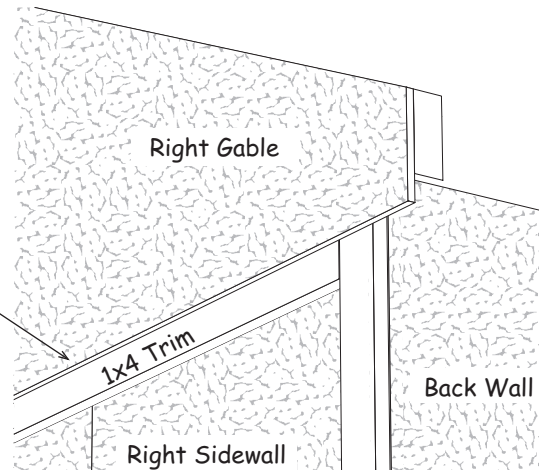

Step 11 Install Trusses

1. Layout the truss spacing by placing 'X' marks where the trusses will be located. Measure from the inside face of the gable when marking the location of the first truss. **Important:** When marking the back wall, place the 'X' mark on the same side of the line so your trusses are parallel when they are installed.

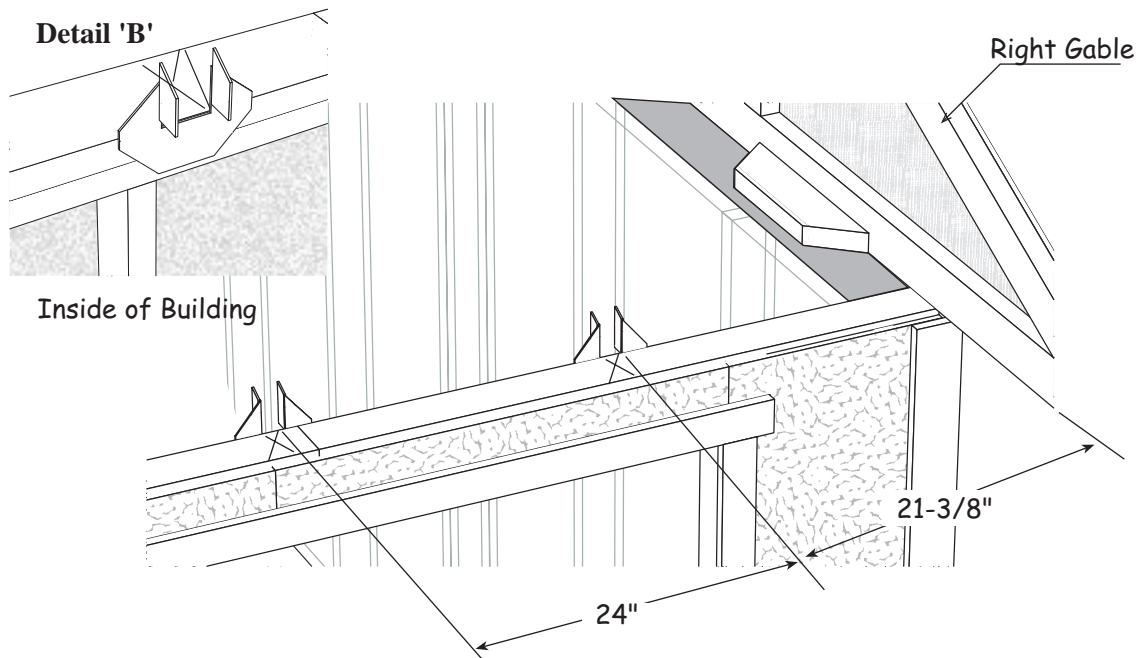

2. Using 1-1/2" hanger nails, install metal hangers to the 2x4 tie plate on the front wall. The opening should line up with the 'X' mark, the bottom of the opening, flush with the 2x4 tie plate. See **Detail 'B'**.

Step 11 Install Trusses Continued

3. Place a truss in the front hanger and over the 'X' mark on the back wall. **Important;** the 2x4, *not the wood gusset*, should cover the 'X' mark on the rear 2x4 plate. Check the truss spacing, front and back, to make sure the truss is parallel.
4. Secure the truss to the back wall by screwing through the rear siding into the end of the truss with a 2-1/2" wood screw. You can also toe nail the truss to the 2x4 tie plate with 10d sinkers.
5. Install the rest of the trusses.

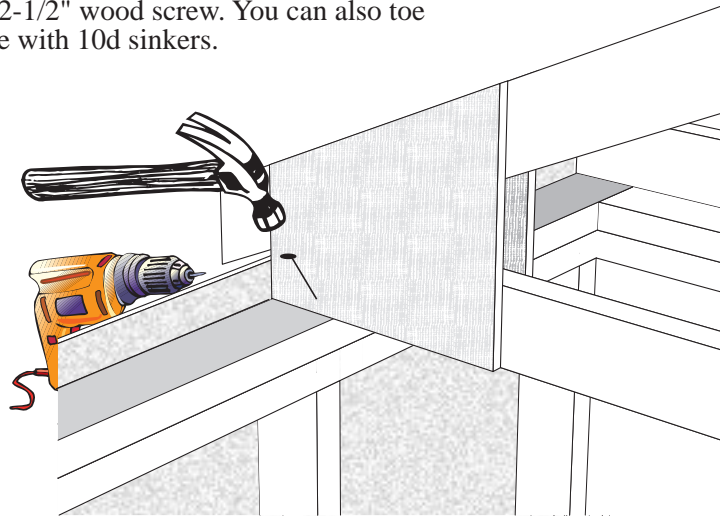

Step 12 Install Rear Soffit & Trim

1. Install pre-cut primed soffit panels under the truss overhang.
2. Install 1x4 trim boards on the rear corners.

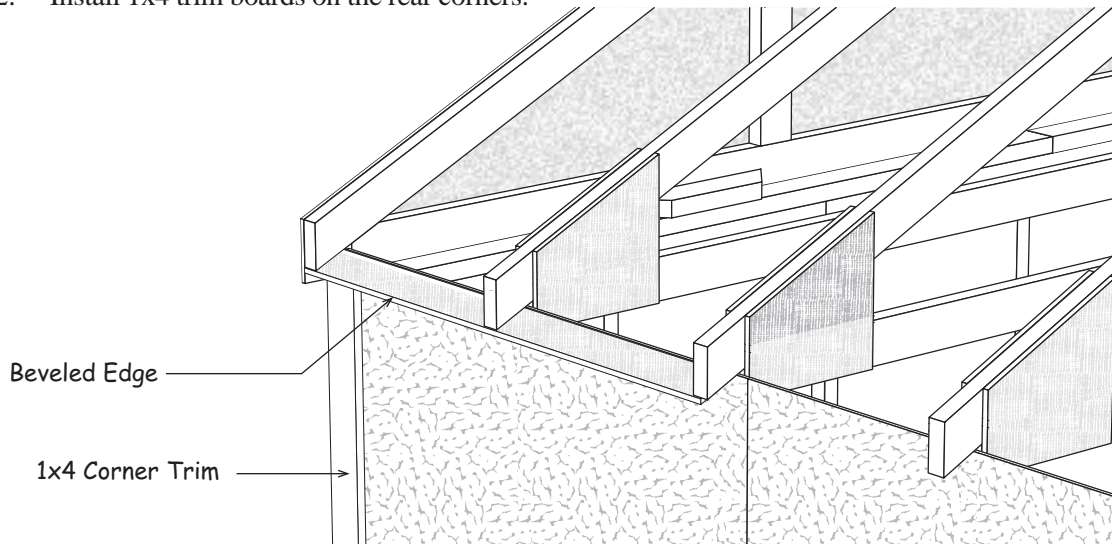

Step 13 Install Front Soffit

1. Secure the front of the trusses to the H1 hangers with 1-1/2" hanger nails.
2. Install 21" soffit panels under the front overhang. Cut the first soffit panel to meet the center of the truss. Fasten to the trusses with 6d galv. nails.
3. Install another 48" wide soffit panel. Cut the last panel to fit.

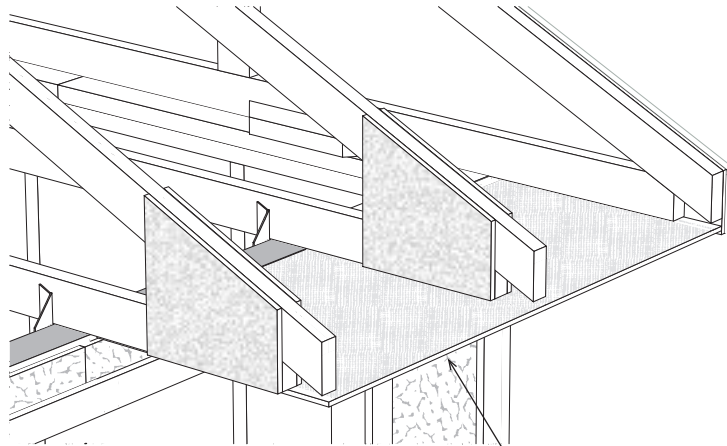

Siding/Soffit Panel

Step 14 Install Gable Trim

Install the 1x4 gable trim extending 1/2" above the siding on the gable. When installed later, the roof sheathing will be flush with the top of the trim.

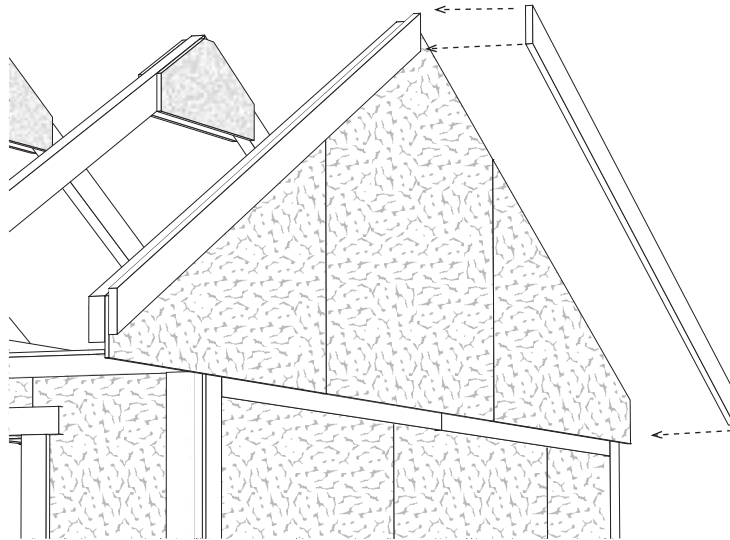

Step 15 Install Roof Sheathing

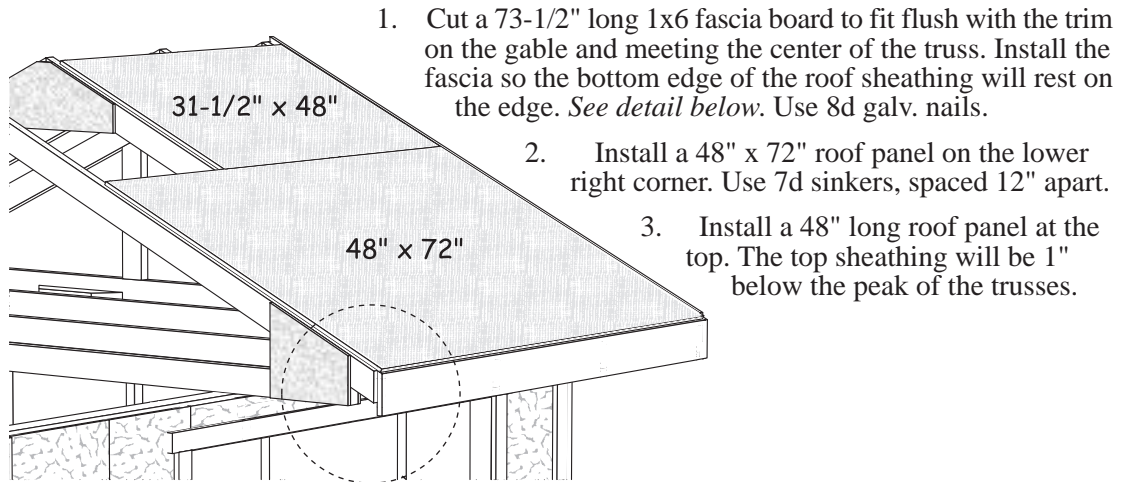

1. Cut a 73-1/2" long 1x6 fascia board to fit flush with the trim on the gable and meeting the center of the truss. Install the fascia so the bottom edge of the roof sheathing will rest on the edge. *See detail below.* Use 8d galv. nails.
2. Install a 48" x 72" roof panel on the lower right corner. Use 7d sinkers, spaced 12" apart.
3. Install a 48" long roof panel at the top. The top sheathing will be 1" below the peak of the trusses.

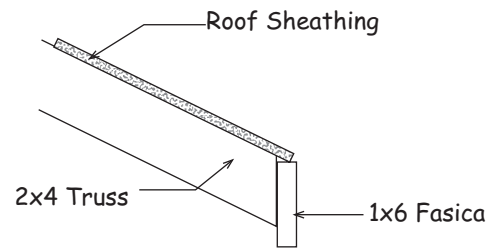

4. Cut and install a 50" long 1x6 trim board flush with the gable trim on the left gable.
5. Install the remaining roof sheathing.

6. Install 1x6 fascia and roof sheathing at the back of the building.

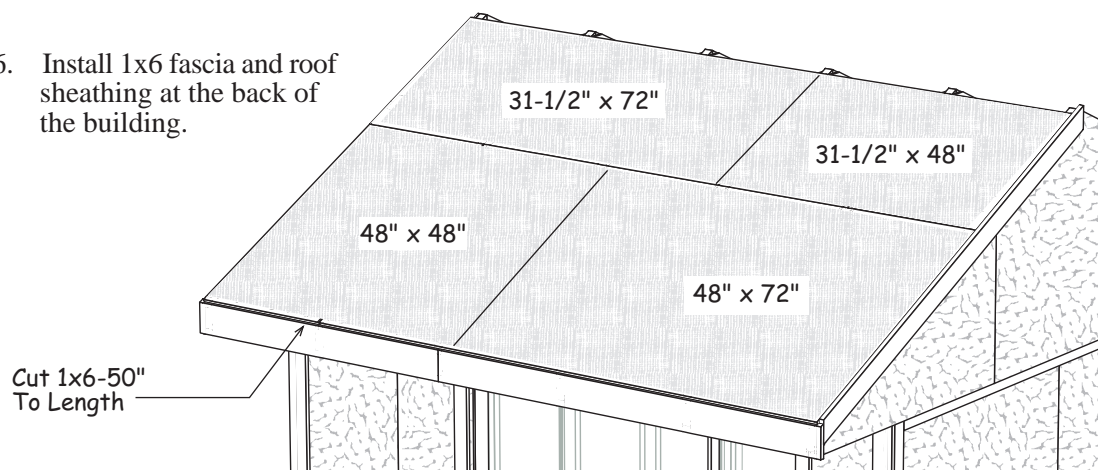

Cut 1x6-50"
To Length

Step 16 Install Loft flooring

1. Gather (2) two 24" x 48" and (2) two 16-1/2" x 48" pieces of OSB sheathing. Install these panels over the bottom 2x4 truss member. Secure with 7d sinkers.
2. Notch panels around gable studs.

3. Cut the first 24"x 48" panel to meet the center of the 2x4 truss.

16-1/2" x 48" Sheathing

4. Repeat to install loft flooring at the other end of the building.

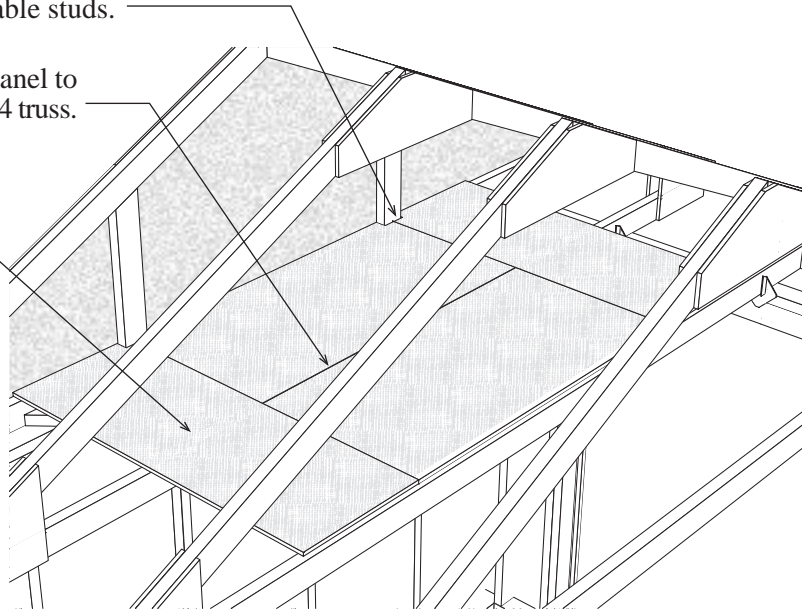

Install Roofing — Not Supplied in Kit

1. Install metal roof edging perimeter of the roof area. If you are not installing shingles at this time, you can purchase felt paper to protect the roof sheathing. Install the felt paper before you install the metal roof edge.
2. Install shingles according to the instructions on the wrapper. If you need more detailed instructions on installing shingles, there are good publications at book stores or newsstands.

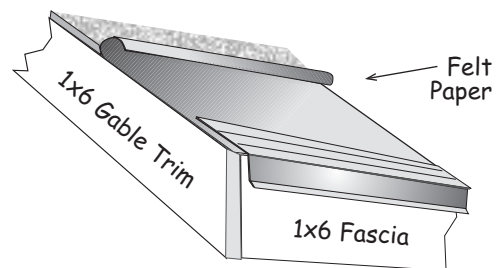

Building Tip: Install ridge vent in lieu of shingles caps. Ridge vent provides ideal ventilation, preventing heat and moisture from damaging your building or its contents.

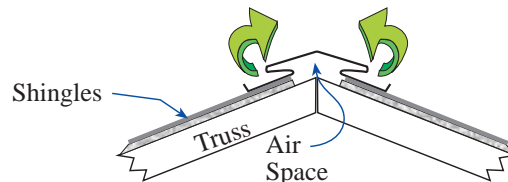

Step 17 Install Doors & Hardware

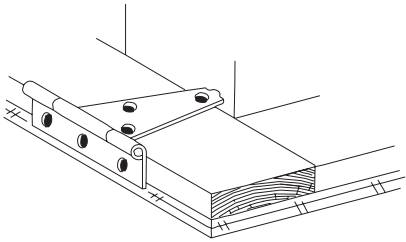

1. Lay the left door with the trim facing up. The siding on the left door extends past the door trim. See detail below.
2. Install 5" hinges to the left side of the door frame. To position the hinge properly, hold the rectangular plate against the frame. Use 1-3/4" black screws.
3. Install hinges to the right side of the other door.

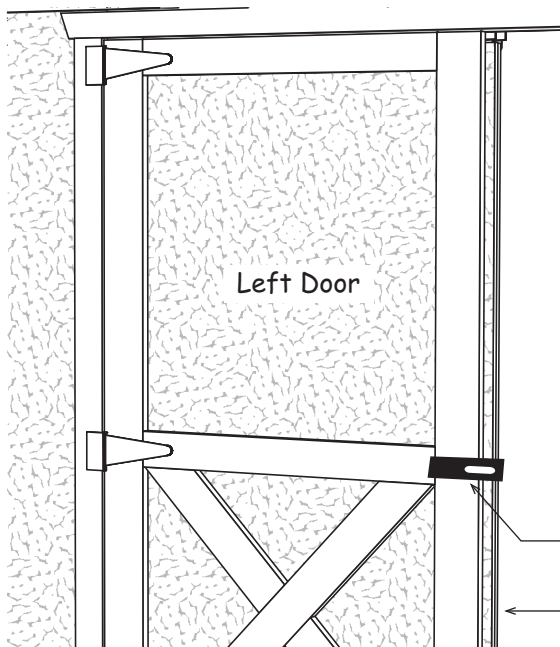

4. Before you fasten the hinges to the door trim, temporarily prop the doors in the opening. Leave a space at the top of the doors and between the doors and the side trim to allow room for the doors to expand when they absorb moisture.

If your door opening is out of square, the space around the doors will not be even. You can remove and reposition the side trim to make allowances for this. The side trim does not have to be flush with the frame of the door opening. You can move the trim in or out to make the door spacing equal.

5. Install hinges to trim with 2" screws.

Barrel Bolt on the back of left door

6. Install a barrel bolt on the lower back of the door to secure this door in place when closed. You will need to drill a hole for the round shaft to drop into.
7. Install another barrel bolt at the top of the door.

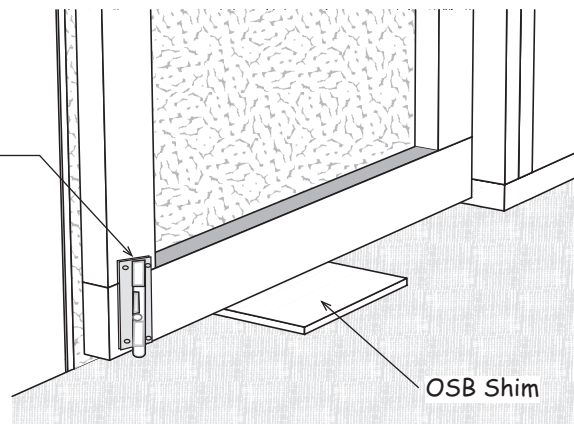

Northwood 10' x 10' Barn kit

Qty.	Description	Size
2x4 Framing		
6	Truss Material - bottom cords	138 "
12	Truss Material-top members	79 5/8"
28	Wall Studs/Plates - black ends	72 "
2	Header Supports - red ends	71 1/2"
2	Wall Plates - green ends	68 1/2"
4	Wall Plates	69 "
4	Wall Plates	51 "
2	Tie Plates	45 "
2	Wall Plates	41 1/2"
2	Wall Plates	31 3/4"
4	Gable Studs	20 7/8"
6	Gable Blocks - angle ends	18 "
2	Wall Plates Code A	10 3/4"
8	Blocks for truss jig	12 "
2	Gauge Blocks for trusses	3" x 7"
7/16" OSB Material		
2	48" x 72" Roof Sheathing	
2	48" x 48" Roof Sheathing	
2	31-1/2" x 72" Roof Sheathing	
2	31-1/2" x 48" Roof Sheathing	
4	24" x 48" Loft Flooring	
4	16" x 48" Loft Flooring	
Primed Soffit Material		
3	48-3/4" x 21" Front Soffit Panels	
3	48-3/4" x 3" Back Soffit Panels	
Wood Gussets		
8	8" x 34" Wood Gussets	
16	12" x 12" Wood Gussets	

Packing List

20-May-14

Qty.	Description	Size
1x6 White Pine Fascia		
2	1x6 Fascia	73 1/2"
2	1x6 Fascia	50 "
White Pine Trim		
4	1x4 Gable Trim	79 5/8"
2	1x4 Corner Trim	79 "
2	1x4 Corner Trim	76 3/4"
4	1x4 Corner Trim	77 1/4"
2	1x3 Door Trim	72 "
1	1x3 Door Trim	71 3/4"
4	1x4 Wall Trim	58 1/2"
Pre-built Components		
2	32" x 72" Barn Doors	
1	Pre-built 67-1/2" Door Header	
Hardware		
3	lb. 10d Sinkers	6 5" Door Hngles
3	lb. 8d Galv. Nails	2 Barrel Bolts
2	lb. 7d Sinkers	1 Door Latch
2	lb. 6d Common	1 Bottle Glue
1	lb. 6d Galv.	48 Hinge Screws
4	H1 Truss Hangers	1 Screw Bit
LP Wall Siding		
2	48-3/4" x 77-1/4"	2 48-3/4" x 79"
1	45-3/4" x 77-1/4"	1 20-3/4" x 79"
1	27-3/4" x 77-1/4"	1 45" x 77-1/4"
1	21-1/2" x 77-1/4"	1 27" x 77-1/4"
1	16" x 77-1/4"	1 16" x 77-1/4"
LP Gable Siding		
2	48-3/4" x 39-1/2" high	
4	48-3/4" x 28" high	