

EMERGENCY **S**ECURITY **P**REAREDNESS **SAFETY SHELTER**

ESP Shelter Consultation
800.222.8183
email: esp@swisherinc.com



BOLT TOGETHER MODULAR DESIGN FOR EASE OF CONSTRUCTION AND RELOCATION

BENCH, SHELF, GUN RACK AND ADDITIONAL INTERIOR ACCESSORIES AVAILABLE

EMERGENCY PANELS FOR RAPID SHELTER EXIT

QUICK MANIPULATING LOCKING MECHANISM WORKS IN CONJUNCTION WITH A LATCH/KEY LOCK

QUICK RELEASE "SLIDING DOOR DESIGN" ALLOWS OPENING WHEN BLOCKED BY DEBRIS AND REDUCES SPACE REQUIRED FOR OPERATION

SHIELDED AIR VENTS ALLOW UNINTERRUPTED AIR FLOW



AVAILABLE IN 5 SIZES
SR84X039G

- Internal 80"L x 35W x 76H
- External 87"L x 42"W x 78"H
- Up to 6 Person Capacity

SR84X054G

- Internal 80"L x 50"W x 76"H
- External 87"L x 57"W x 78"H
- Up to 9 Person Capacity

SR84X084G

- Internal 80"L x 80"W x 76"H
- External 87"L x 87"W x 78"H
- Up to 14 Person Capacity

SR84X114G

- Internal 80"L x 110"W x 76"H
- External 87"L x 117"W x 78"H
- Up to 20 Person Private / 12 Person Business

SR84X144G

- Internal 80"L x 140"W x 76"H
- External 87"L x 147"W x 78"H
- Up to 25 Person Private / 15 Person Business



**TESTED TO MEET OR EXCEED
FEMA 361 & ICC500 BY NWI DIF
AT TEXAS TECH UNIVERSITY**



SWISHER[®]
www.ESP.swisherinc.com



EMERGENCY SECURITY PREPAREDNESS SAFETY SHELTER

ESP Shelter Consultation
800.222.8183
email: esp@swisherinc.com

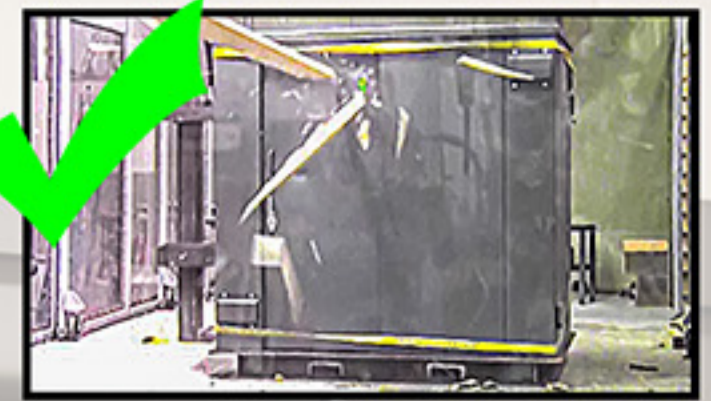

TESTED TO MEET OR EXCEED
FEMA 361 & ICC500 BY NWI DIF
AT TEXAS TECH UNIVERSITY

SR84X039G

- Internal 80"L x 35"W x 76"H
- External 87"L x 42"W x 78"H
- Up to 6 Person Capacity

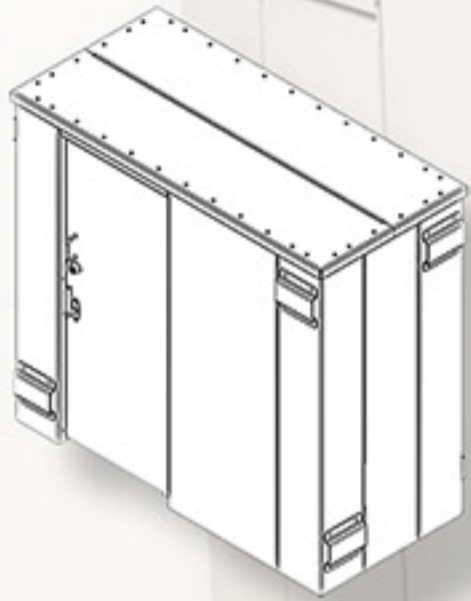

SR84X054G

- Internal 80"L x 50"W x 76"H
- External 87"L x 57"W x 78"H
- Up to 9 Person Capacity

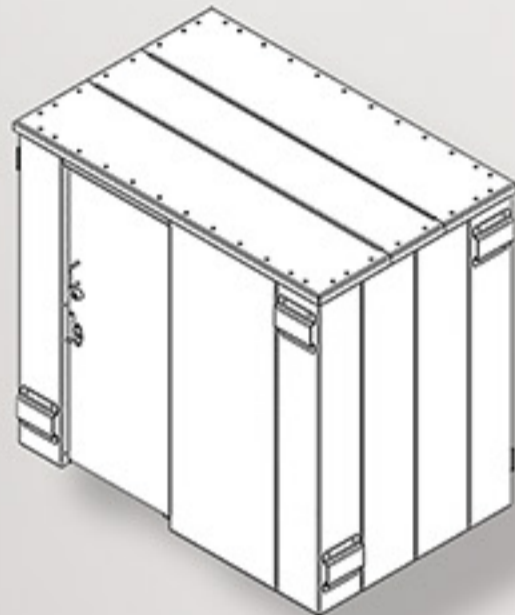

SR84X084G

- Internal 80"L x 80"W x 76"H
- External 87"L x 87"W x 78"H
- Up to 14 Person Capacity

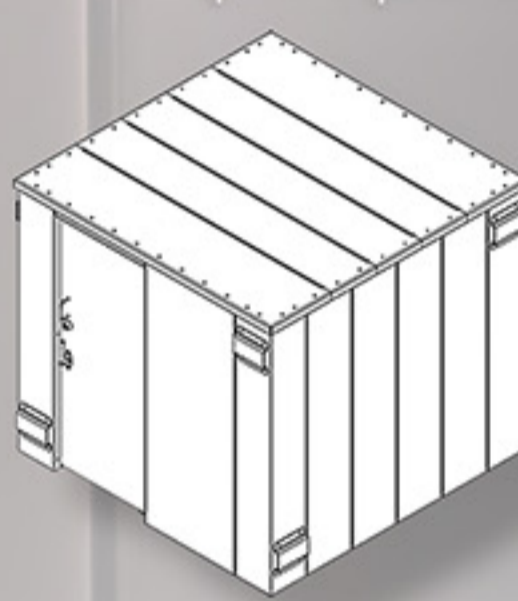

SR84X114G

- Internal 80"L x 110"W x 76"H
- External 87"L x 117"W x 78"H
- Up to 20 Person Private / 12 Person Business

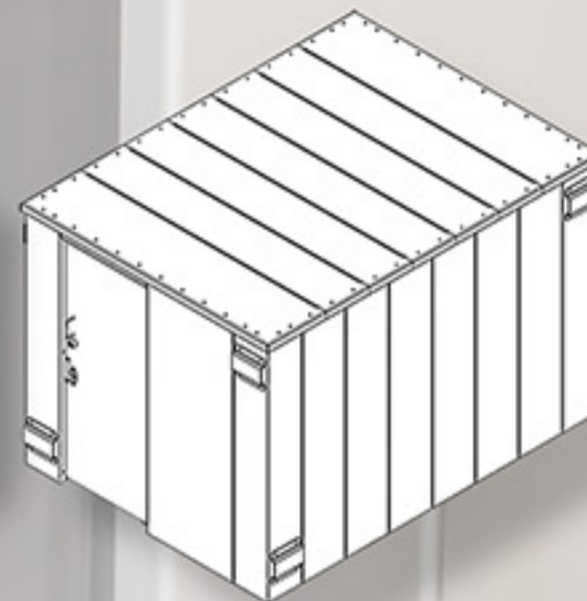

SR84X144G

- Internal 80"L x 140"W x 76"H
- External 87"L x 147"W x 78"H
- Up to 25 Person Private / 15 Person Business

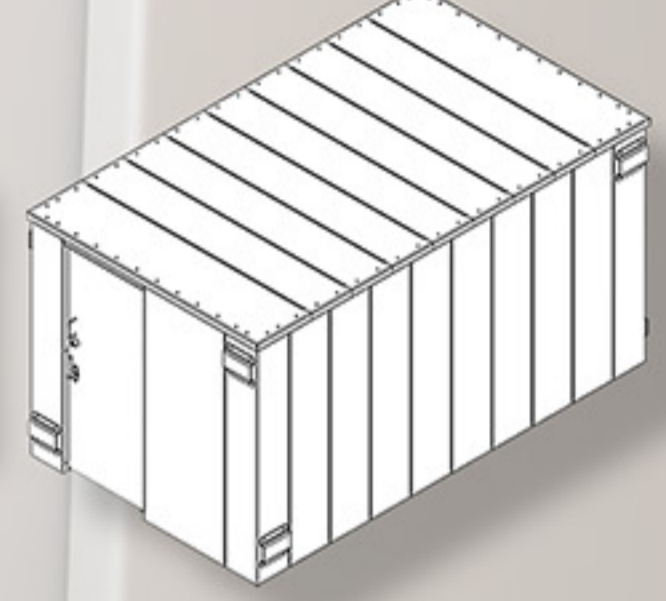

Shielded air vents
allow uninterrupted
air flow

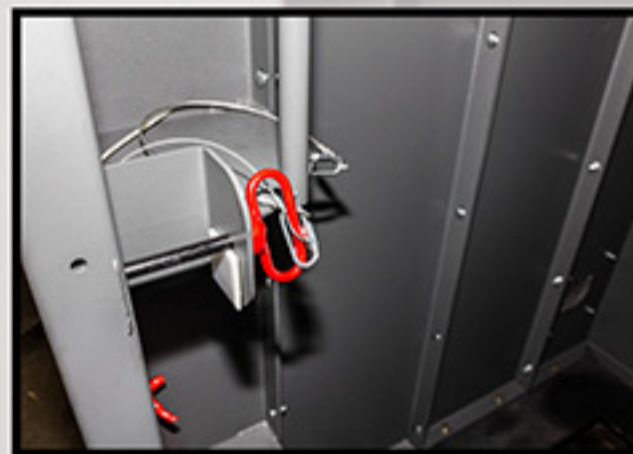

Quick release
"Sliding Door Design"
allows opening when
blocked by debris



Bolt together modular
design for ease of
construction and
relocation
*Excluding Concrete Foundation



Ample head space for
added comfort
and security



Patent pending
"Sliding Door Design"
offers multiple
performance advantages
vs. traditional doors



Removable emergency
panels for rapid
shelter exit



Quick manipulating
locking mechanism
works in conjunction
with security grade
deadbolt latching system

WARRANTY

5 YEARS AGAINST
MANUFACTURER DEFECTS

LIMITED LIFETIME AGAINST
TORNADO DAMAGE

Your investment is
quality assured and
backed by Swisher's
limited lifetime
warranty

SWISHER[®]
www.ESP.swisherinc.com



EMERGENCY SECURITY PREPAREDNESS SAFETY SHELTER

ESP Shelter Consultation
800.222.8183
email: esp@swisherinc.com

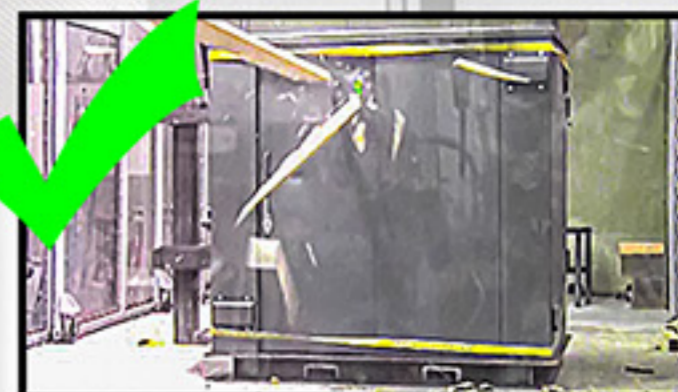

TESTED TO MEET OR EXCEED
FEMA 361 & ICC500 BY NWI DIF
AT TEXAS TECH UNIVERSITY

ACCESSORIES



SRAC20221
Single Panel Wide
Shelf



SRAC20226
Double Panel Wide
Shelf



SRAC20229
Bench



SRAC20282
Standard Gun Rack



SRAC20338
Deluxe Adjustable
Gun Rack



SRAC19840
Eva-Dry Reusable
Dehumidifier
Up to 500 cu-ft



SRAC20270
Striker FLEXiT
Flexible L.E.D.
Magnetic Light



SRAC20389
Dorcy
Motion Sensor L.E.D.
Magnetic Light



SRAC20390
Kaito Emergency
Radio with Built
In L.E.D. Light



SRAC20391
ESP Combo Pack 1
Motion Sensor L.E.D.
Emergency Radio
Eva-Dry Dehumidifier



SRAC20392
ESP Combo Pack 2
(2) Motion Sensor L.E.D.
Emergency Radio
(2) Eva-Dry Dehumidifier

SWISHER[®]
www.ESP.swisherinc.com

