

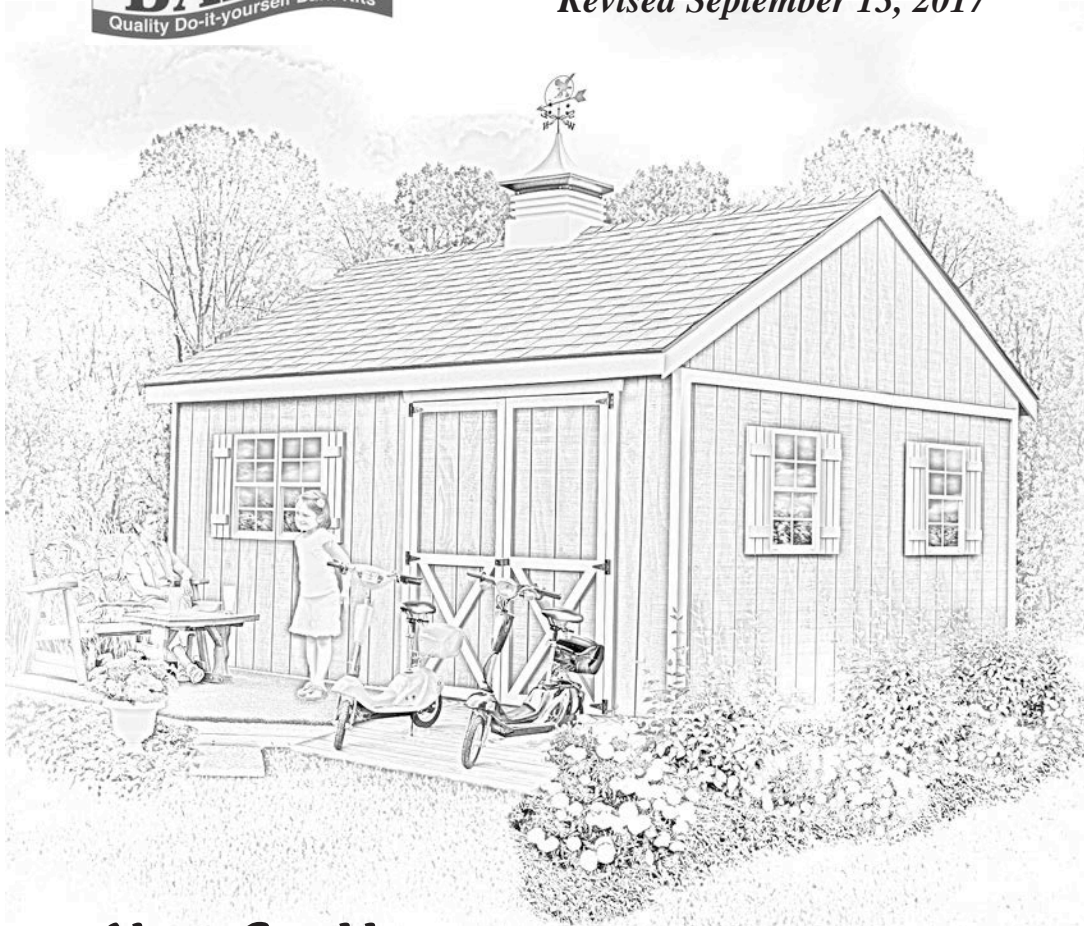

Best Barns USA Assembly Book

Revised September 13, 2017



New Castle

Building Size 12'x16'

Manufactured by Reynolds Building Systems, Inc.

205 Arlington Drive Greenville, PA 16125

This manual is copyrighted. Under the copyright laws, this manual may not be copied, in whole or in part, without consent from Reynolds Building Systems, Inc. © Copyright 2011

IMPORTANT INFORMATION ABOUT YOUR SHED KIT

Download the most current instruction book at www.barnkits.com; use the "manuals" link on the menu bar and then select your building kit and size.

The foundation size should measure 12'-0" wide by 15'-9" long. **Do Not** make the foundation larger than the building size. The siding should project beyond the foundation for water to expel properly from the sidewalls. The material has been pre-cut for easy assembly. However, this material will only fit together properly if your foundation is level and square.

Read the instructions before starting the assembly of the building. If you have any questions about assembling the kit, call 800-245-1577. Business hours (8:00-5:00 ET) Monday thru Friday. After business hours call 724-866-HELP (4357) or email to help@barnkits.com.

The material that is included in our kit is listed on the back page. The optional floor package, if purchased, will be supplied by a local lumber supplier.

Our kit does not include the shingles; the quantity needed is listed on the back page. The siding is primed. You will need to apply a finish coat using latex acrylic paint.

Some of the framing lumber was used in the shipping pallet. Unpack the material from the pallets, then unscrew the OSB sheathing, it will be used for roof sheathing. Unscrew the 2x4s from the shipping pallet. This material will be used for wall bracing. The bit for the screws is packed in the hardware bag.

Stacking the boards, according to size, will make them easier to find when needed. Some boards may have colored ends.

Before you begin construction, be sure to study this assembly manual. Also, obtain a building permit and check all pertinent building code regulations.

Thank you for your purchase.

Bill & Linda Rinella, owners

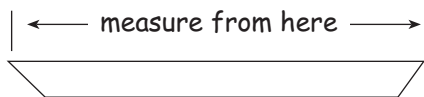

When measurements are given for a board length or width, it is from the longest side.

Tool List

- | | |
|---|--|
| <input type="checkbox"/> Hammer & Hand Saw | <input type="checkbox"/> Power Drill/screwdriver |
| <input type="checkbox"/> Framing Square & Level | <input type="checkbox"/> Measuring Tape |
| <input type="checkbox"/> Power Circular Saw | <input type="checkbox"/> 2-8' Step Ladders |

Always wear safety glasses when cutting or nailing!

Constructing Details for Deluxe Floor System

Deluxe floors include 4x4 runners, standard floors do not

Foundation size is 12'-0" x 15'-9". Check local building codes in your area, the construction may have to change. For a concrete slab, install sill sealer as a moisture barrier between the concrete and the wall plates. Foam sill sealer can be purchased at home centers in rolls 3-1/2" or wider.

1. Cut (2) two 2x4-8' boards into 2' long blocks. Butt the 4x4-8' timbers together to make 16' runners. Secure the 4x4s together with the 2' long 2x4 blocks and 16d galvanized nails.
2. Cut (2) two 2x4 joist headers to 15' - 9". Layout for 16" on center joist spacing. 'X' marks where floor joist will be placed.

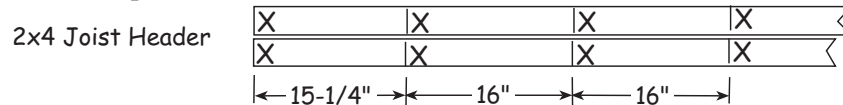

3. Cut 2x4-12' floor joist to 11'-9". *Treated lumber may be thicker than 1-1/2". Take this into account when cutting the length of floor joists. Shorten joist measurements if necessary to obtain 12'-0" building width.*

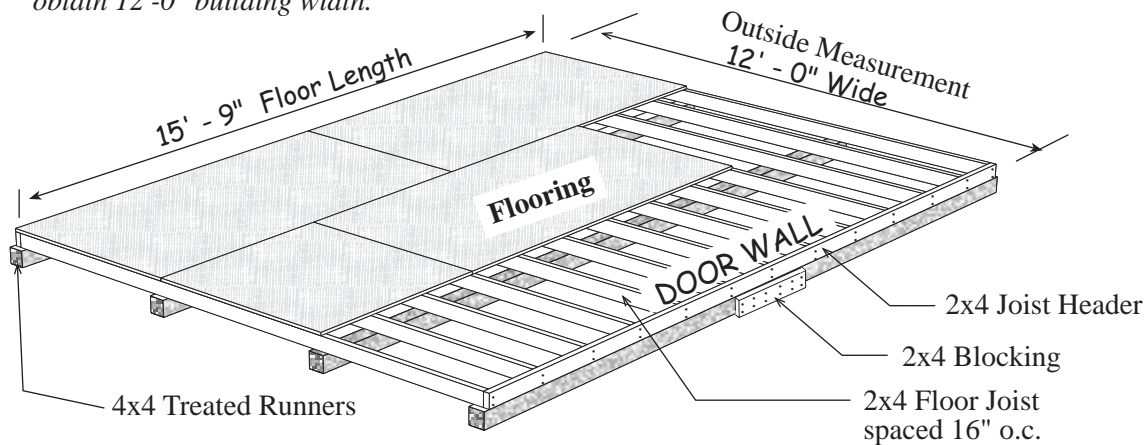

It is important that the floor be level and square. Square the floor as follows: before nailing the flooring, measure the floor diagonally (corner to corner). Then measure the opposite corners; these measurements will be the same when the floor is square. Toenail frame to the 4x4 runners.

Install the flooring with 8d galvanized nails spaced 8" apart.

Material Description	Qty. & Size
2x4 Treated Blocking	2 pcs. 8'
2x4 Treated Floor Joists	13 pcs. 12'
2x4 Treated Joist Headers	2 pcs. 16'
4x4 Treated Runners	8 pcs. 8'
Flooring: 5/8" or 3/4"	6 pcs. 4x8
Galv. Spiral Floor Nails	3 lbs. 8d
Galvanized Deck Nails	3 lbs. 16d

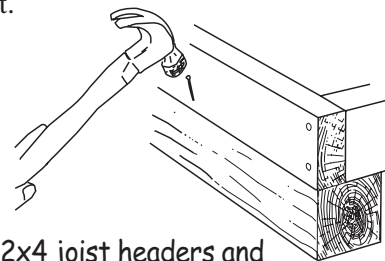

Nail 2x4 joist headers and floor joist to 4x4 runners.

Step 1 Assemble Trusses



Building Tip: To aid in the assembly of the trusses, temporarily screw 2x4 blocks to the floor. There are short 2x4s, *that may have an angle on one end*, supplied in kit. This will insure that all the trusses are assembled the same.

1. Screw (2) two 2x4 blocks to the 12' wide end of the floor at the corner, *see below*.
2. Place two truss legs together. Position the notch in the 2x4s (called a bird's mouth) into the 2x4 blocks. **Important:** You must have 12'-0" between the bird's mouth. Affix more 2x4 blocks above the truss legs to hold the truss members in place.
3. Secure the tops together with a wood gusset. Apply wood glue between the 2x4 boards and the gusset. Nail the gusset to the 2x4s with 6d common nails. Use 14 nails per gusset.
4. Install a 2x4-90° collar tie between the 2x4 boards. Hold in place with 2x4 blocks. Install 12"x24" gussets to the ends of the collar tie. Glue and nail using 14 nails per gusset.
5. Turn this truss over and apply wood gussets to the opposite side.
6. Repeat 2 through 5 to assemble (6) six more trusses.

Do Not remove blocks from floor until completing **Step 2**.

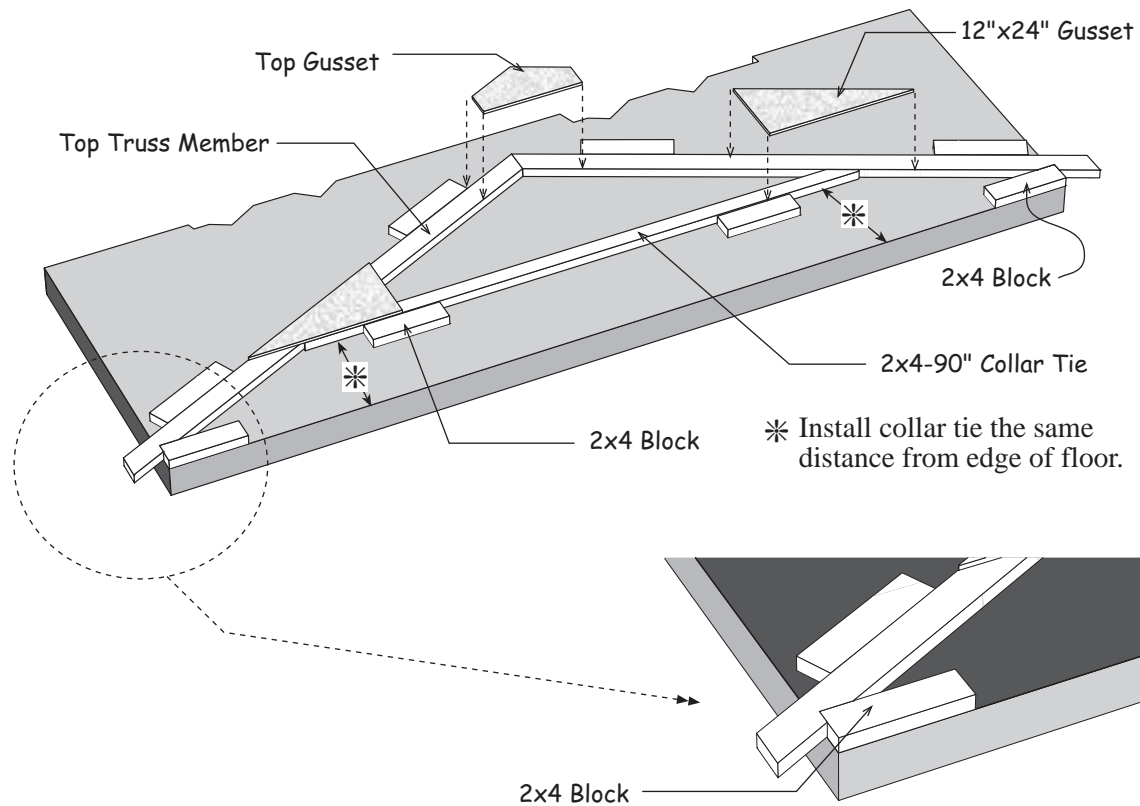

Step 2 Assemble Roof Gables

1. Butt (2) two 72" long 2x4s together and secure by nailing a 3-1/2" x 31-3/4" long plywood gusset across the top where they butt together. Use glue and 6d common nails.

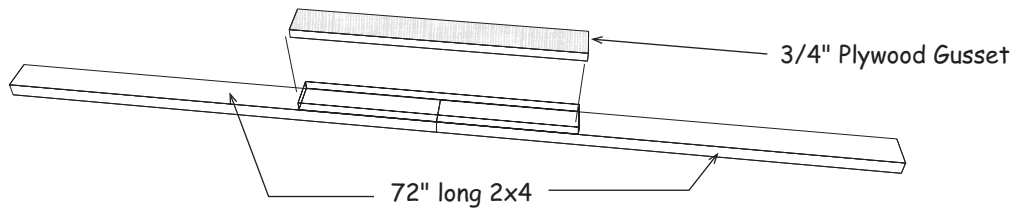

2. Place (2) two truss members in the jig. Secure the top together with a barbed metal plate.
3. Remove the 2x4 blocks at the corners of the floor and insert the gable plate assembled above into the bird's mouth. Make sure the 2x4 gable plate is straight. If necessary, tack 2x4 blocks to hold plate straight.

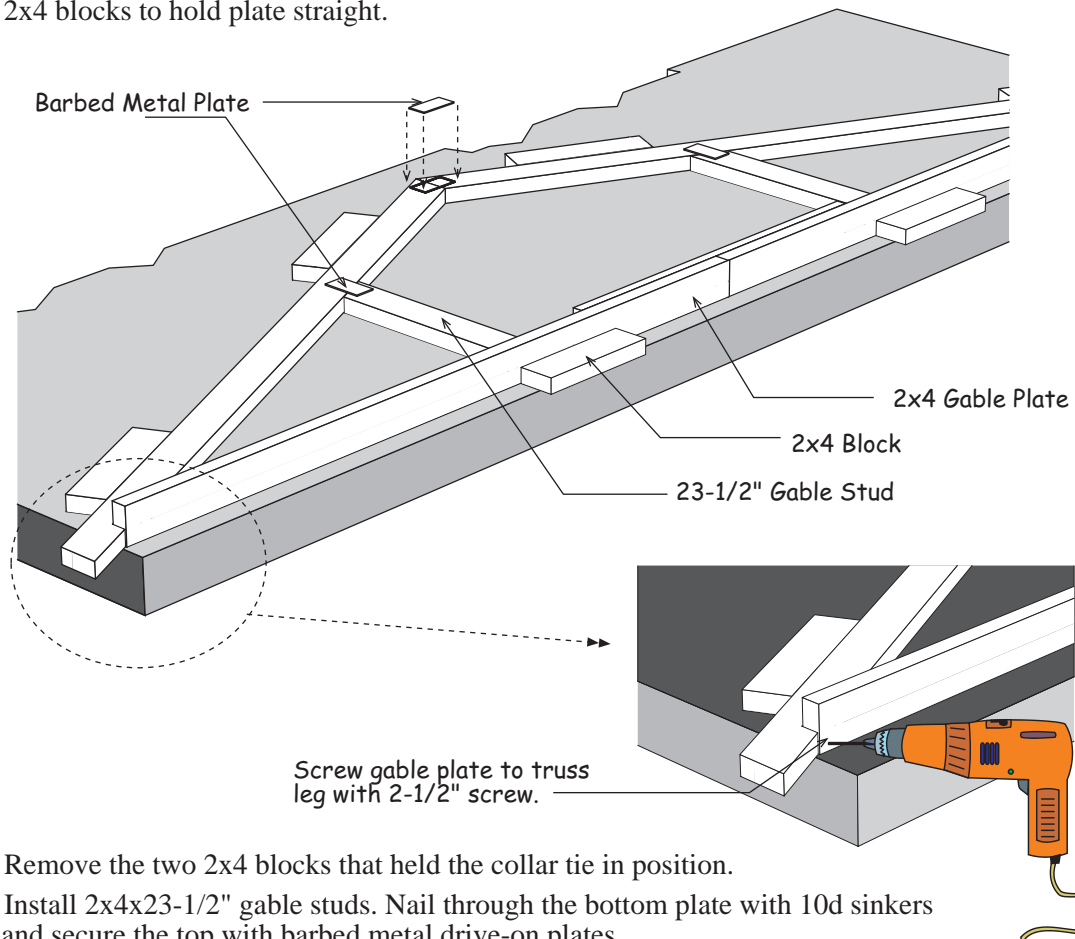

4. Remove the two 2x4 blocks that held the collar tie in position.
5. Install 2x4x23-1/2" gable studs. Nail through the bottom plate with 10d sinkers and secure the top with barbed metal drive-on plates.
7. Repeat to assemble another gable. Remove 2x4 blocks.

Step 3 Install Siding on Gables

Exterior Siding

The siding is made in 4x8 sheets with grooves cut into the face, the long edge is beveled so that the siding overlays where they butt.

To identify which edge we want you to use, we will refer to the edge as either the 'LAP' Edge or the Tongue Edge. Nail siding on walls with 8d galv. nails, spaced 12" apart. Use 6d galv. nails on gable siding only.

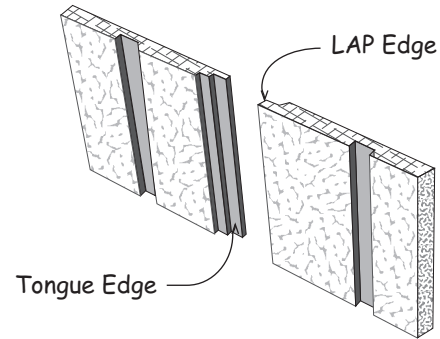

1. Select one of the gable frames, Turn the gable over letting the bottom plate overhang the floor so the gable lays flat.
2. Locate (2) two small siding pieces to cover gable ends. These may or may not have grooves and will be covered by trim in a later step. Install on the left flush with top and end of gable frame . Use (4) four 6d galv. nails.
3. Install next panel with tongue edge on right side. Siding will extend 3/4" below bottom plate and will not extend above top. Use 6d galv. nails spaced 12" apart.
4. Install remaining panels and end piece.

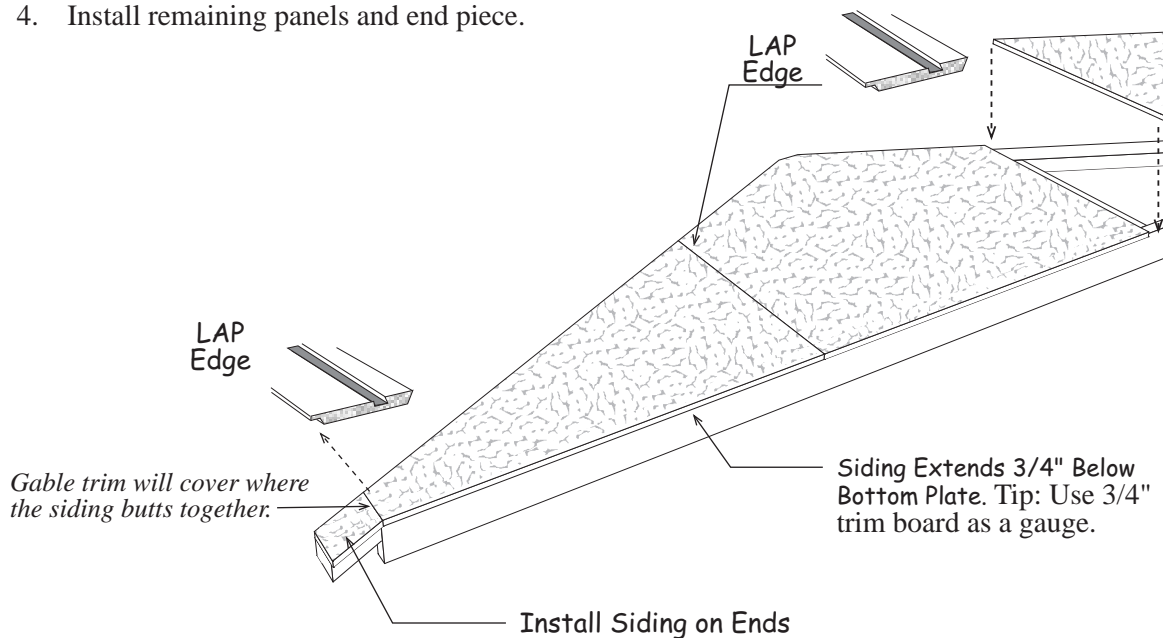

5. Repeat steps to install siding on the other gable frame.

Step 4 Assemble 12' Side Walls

1. Position 2x4-68-1/2" boards together and indicate with 'X' marks, where the wall studs will be located. Mark the ends that will butt together with the letters 'A' and 'B'.

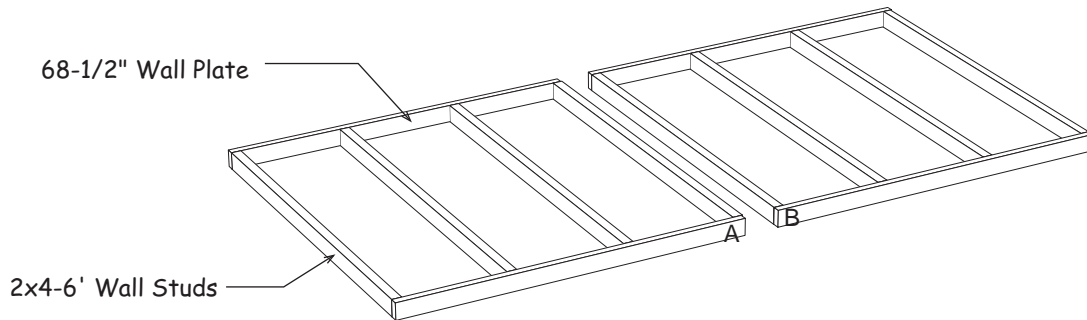
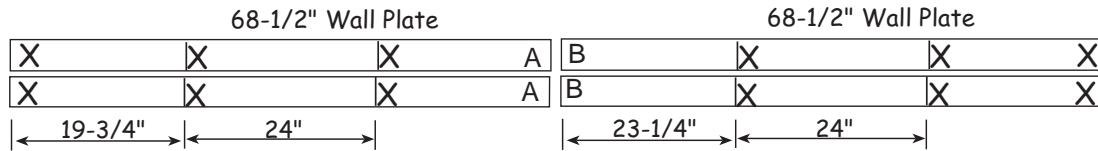

2. Install 72" wall studs between the top and bottom plates. Assemble wall frames with 10d sinkers, (2) two nails at each stud end. Nail both wall frames together.
3. Square wall frame. *Measure diagonally (corner to corner). The measurements will be the same when the wall is square.*
4. Install the 1st siding panel with the 'LAP' edge extending 3-1/2" past the wall frame. The bottom will extend 3/4" below the bottom plate. Use 8d galv. nails.
5. Install the other siding panels. Cut the last panel to extend 3-1/2" beyond the wall frame.

 **The siding will be 1/2" below the top of the wall frame on all walls.**

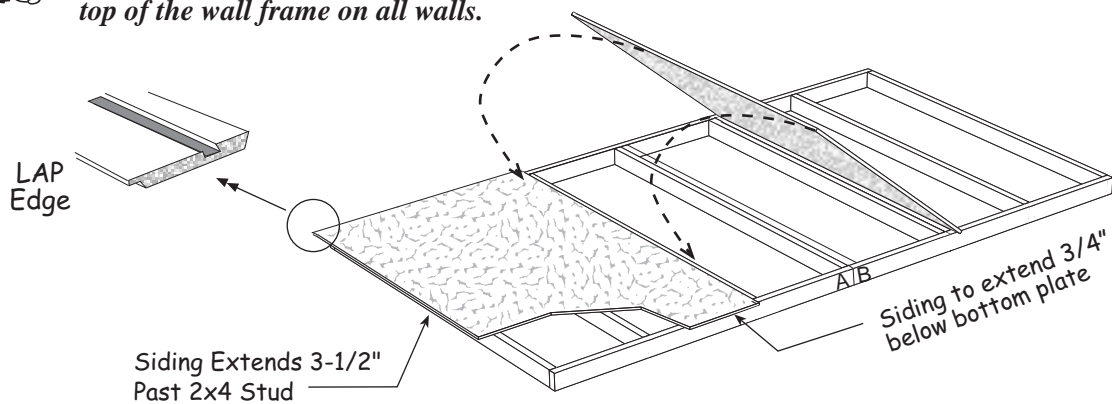

6. Repeat to assemble another sidewall.

Step 5 Assemble Back Wall

1. Position 2x4-72" boards together and indicate with 'X' marks, where the wall studs will be located.

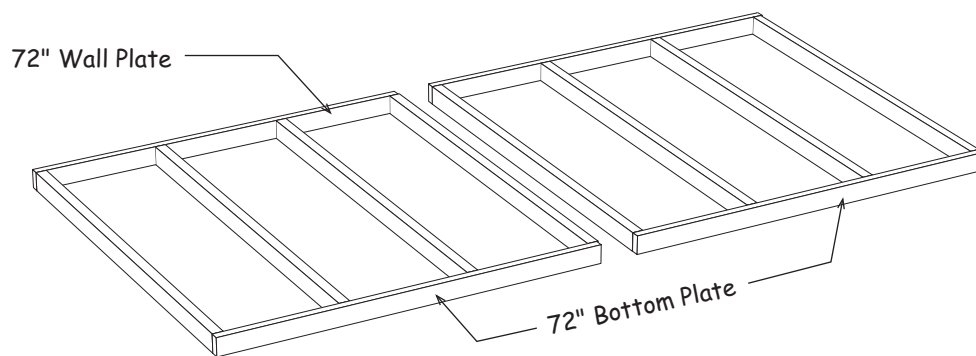
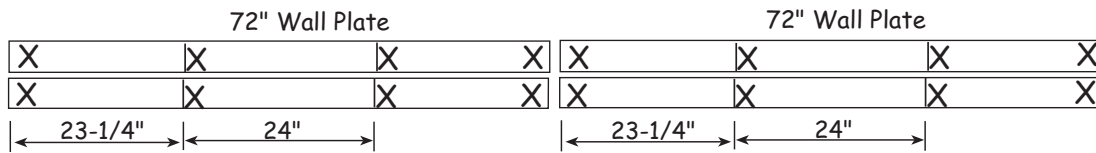

2. Install 72" wall studs between the top and bottom plates. Nail both wall frames together.
3. Square wall frame.
4. Install the first siding panel with the 'LAP edge' flush the end of the wall and extending 3/4" below the bottom plate.
5. Install (2) two more siding panels.

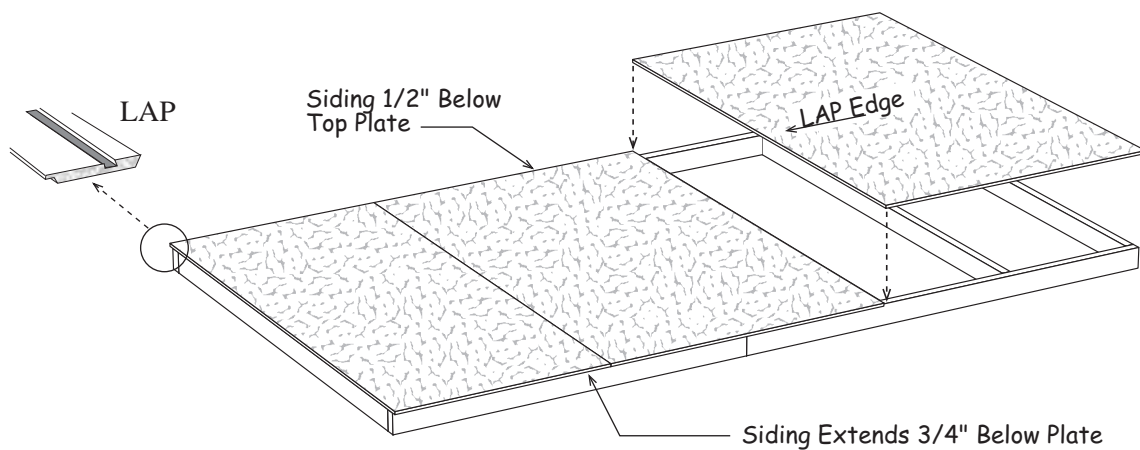

Step 6 Assemble Back Wall Continued

1. Locate (2) two 45" long 2x4s.
2. Install (3) three 2x4-72" wall studs between the boards.
Install the stud in the center of the wall frame.

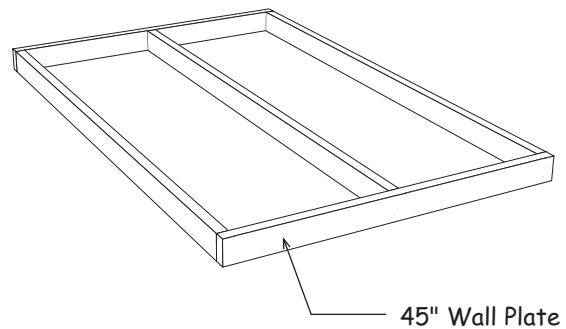

3. Select the 12' sidewalls assembled in **Step 5**. Butt the 45" wall frame against the wall with siding. **DO NOT** nail these frames together so they can be separated later.
4. Cut the last siding panel to be flush with the end of the wall frame. Do not nail along the long edge that overlaps the 12' wall frame. You can nail this edge after the wall panels are installed. This will enable you to separate the wall panels making them easier to handle.

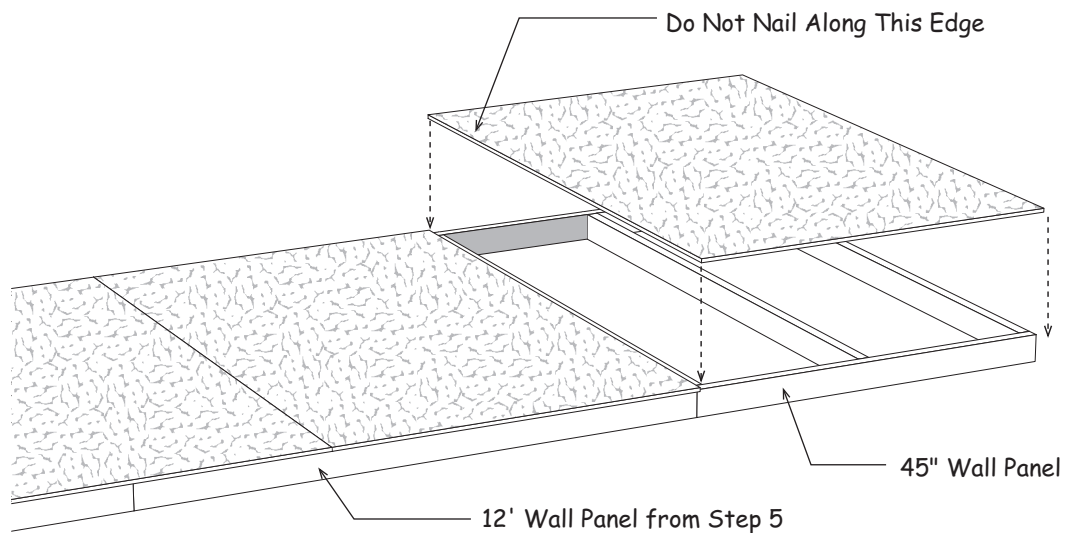

Step 7 Assemble Front Wall Frames

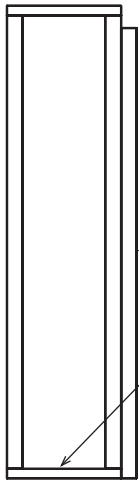

1. Cut (2) two 14-1/2" plates from (2) two 2x4-6' boards. Save the 57-1/2" long cutoffs, they will be used in **Step 12**. Assemble a wall frame using (2) two 72" wall studs and the (2) two 14-1/2" long 2x4 wall plates.

2. Cut a 72" long 2x4 to a length of 71-1/2" and install as a header support on the wall frame.

2x4-14-1/2" Wall Plate

3. Gather the material listed on right to assemble the larger wall frames.

Material Breakdown - Larger Wall Frame

2	2x4	45"	Wall Plates
2	2x4	62"	Wall Plates
7	2x4	72"	Wall Studs
1	2x4	71-1/2"	Header Support

4. Assemble a 62" long and 45" long wall frame.

5. Nail frames together using 10d sinkers.

6. Cut a 72" long 2x4 to a length of 71-1/2" and install as a header support on the wall frame.

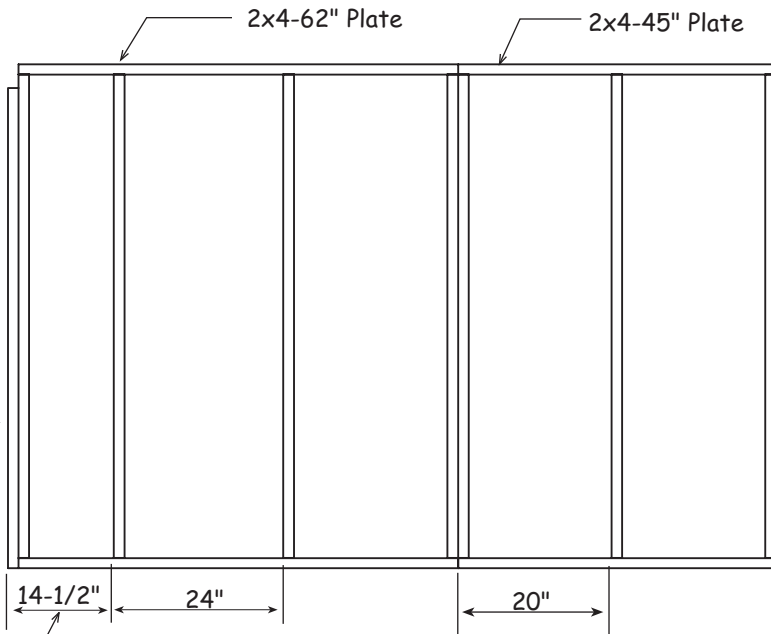

from header support

Step 8 Install Siding on Front Wall Frames

 *If you want the door opening on the right, flip the walls and apply siding to the opposite side of the wall frames.*

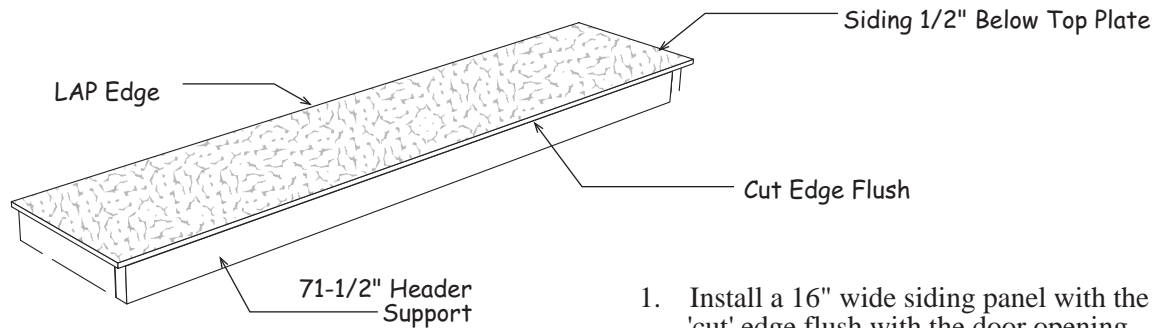

2. Install siding on the larger wall frame.
3. Install 16" siding panel with the 'cut' edge flush with the side of the door opening.
4. Install (2) two siding panels. Cut the last siding panel flush with the end of the wall frame.

 If installing the optional window you can cut the opening in the siding.

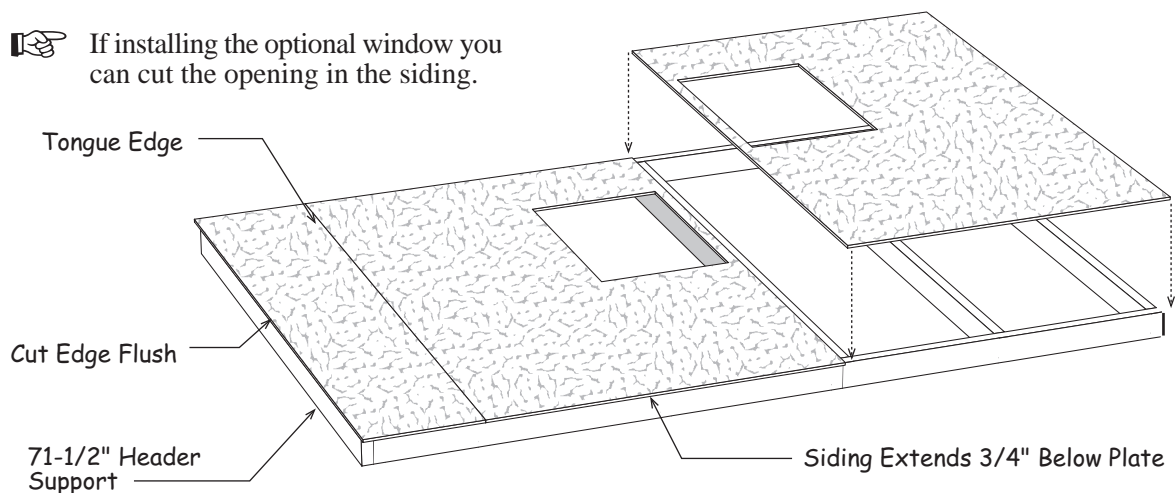

Step 9 Set Walls & Install Door Header

1. Assemble door header using (2) two 67-1/2" long 2x4 boards and OSB filler panel. Glue both sides of OSB. Nail header together with 10d sinkers.
2. Secure wall panels together at the corners. Use (4) four 10d sinkers per corner. Nail wall panels to the floor. Nail through the bottom plate. Space 10d sinkers 24" apart.
3. Install the 2x4 door header between the front wall panels. Nail through the wall stud into the ends of the header. Toenail into the top wall plates.
4. Install 2x4s, *from the pallet*, to hold the wall straight.
5. Nail along the siding edge where it overlaps the 15'-9" long back wall panel.

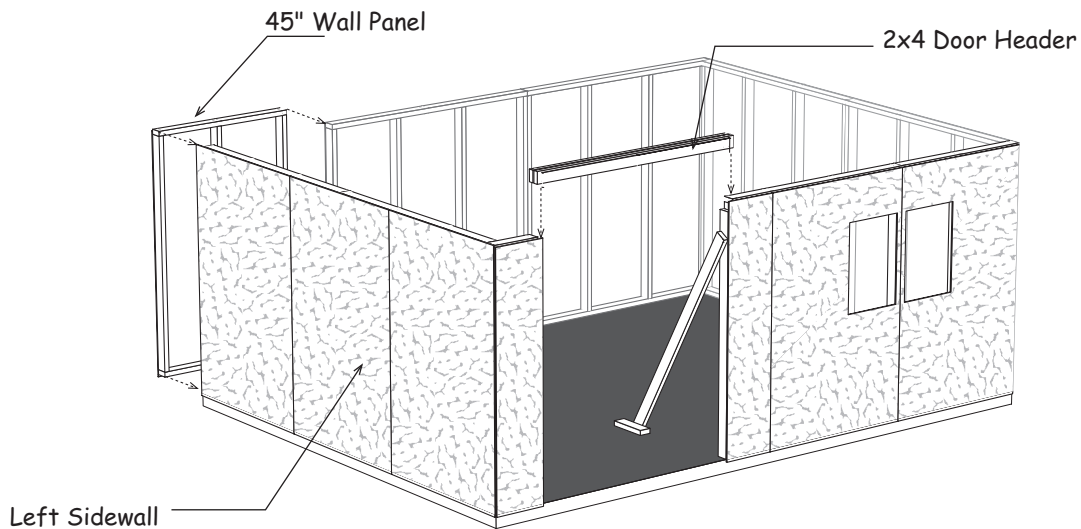
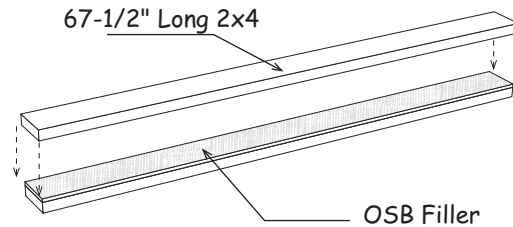

6. Install 3-3/4" x 32-1/2" siding panels over the door header. The siding should extend 3/4" below the door header. Wall trim, installed later, will hide where the siding butts the front wall panels.

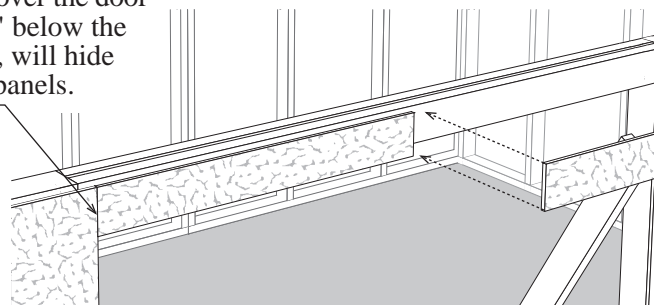

Step 10 Install Sidewall Trim

1. Install (2) two 1x3-75 3/4" corner trim boards to the sidewall. Install trim flush with the 2x4 top plate and flush with the siding on the front wall. Repeat for back wall. Use 8d galv. nails, spaced 12" apart.
2. Butt a 1x4-6' board against corner trim flush with top plate. Next cut to fit and install a 1x4-6' trim board to finish.

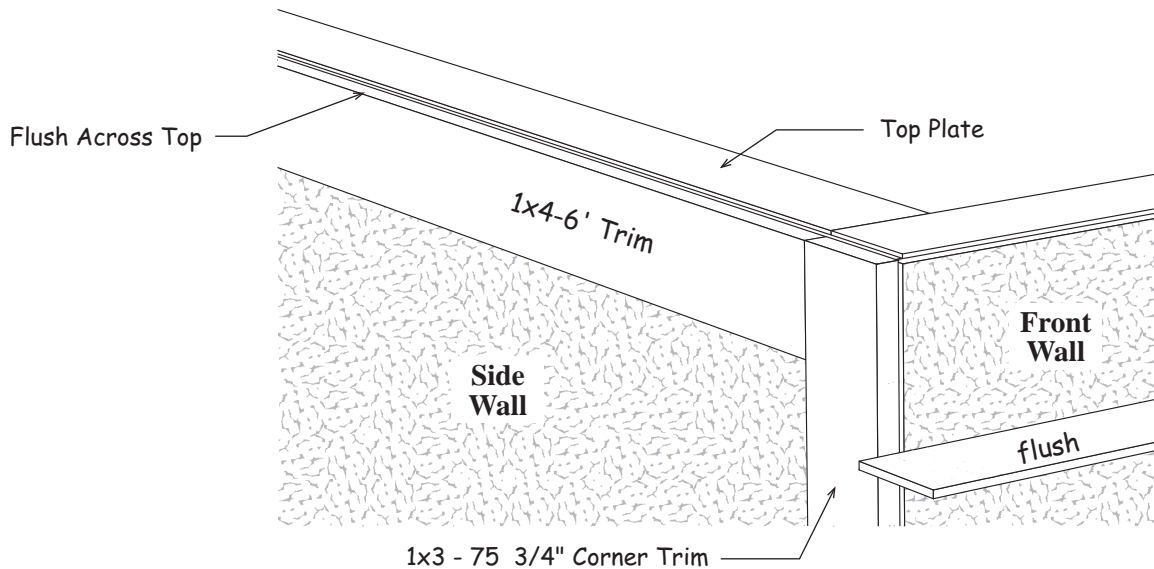

3. Install trim on the opposite sidewall of the building.

Step 11 Install Gable

1. Install a gable on the left sidewall. The gable siding will extend over the 1x4 trim on the lower wall. **NOT behind the trim!**

Secure gable to wall by nailing through the gable plate with 10d sinkers. Nail siding along the 1x4 trim board with 8d galv. nails.

2. Install gable on the opposite sidewall.

Important: Bottom edge of siding extends over 1x4 trim. Paint this edge.

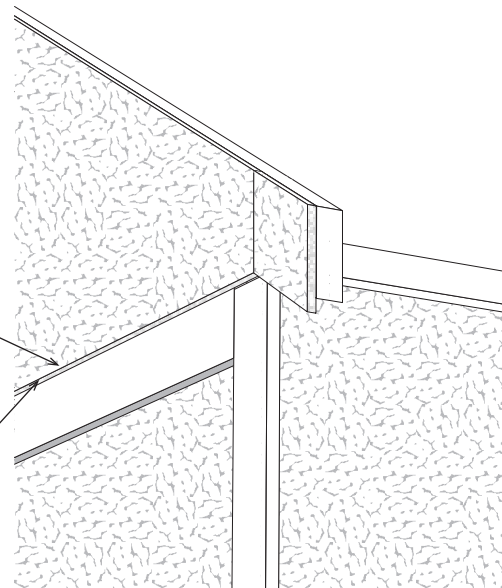

Step 12 Install 2x4 Tie Plates & Door Trim

1. Install 2x4 tie plates, *over the 2x4 wall plate*, on the back wall. Install (2) two 2x4-6' boards starting at the back left corner.
2. Cut a 57-1/2" long 2x4 (cutoff from **Step 7**) to finish.
3. Install (2) two 2x4-6' boards on the front wall starting at the front right corner.
4. Cut a 57-1/2" long 2x4 (cutoff from **Step 7**) to finish.

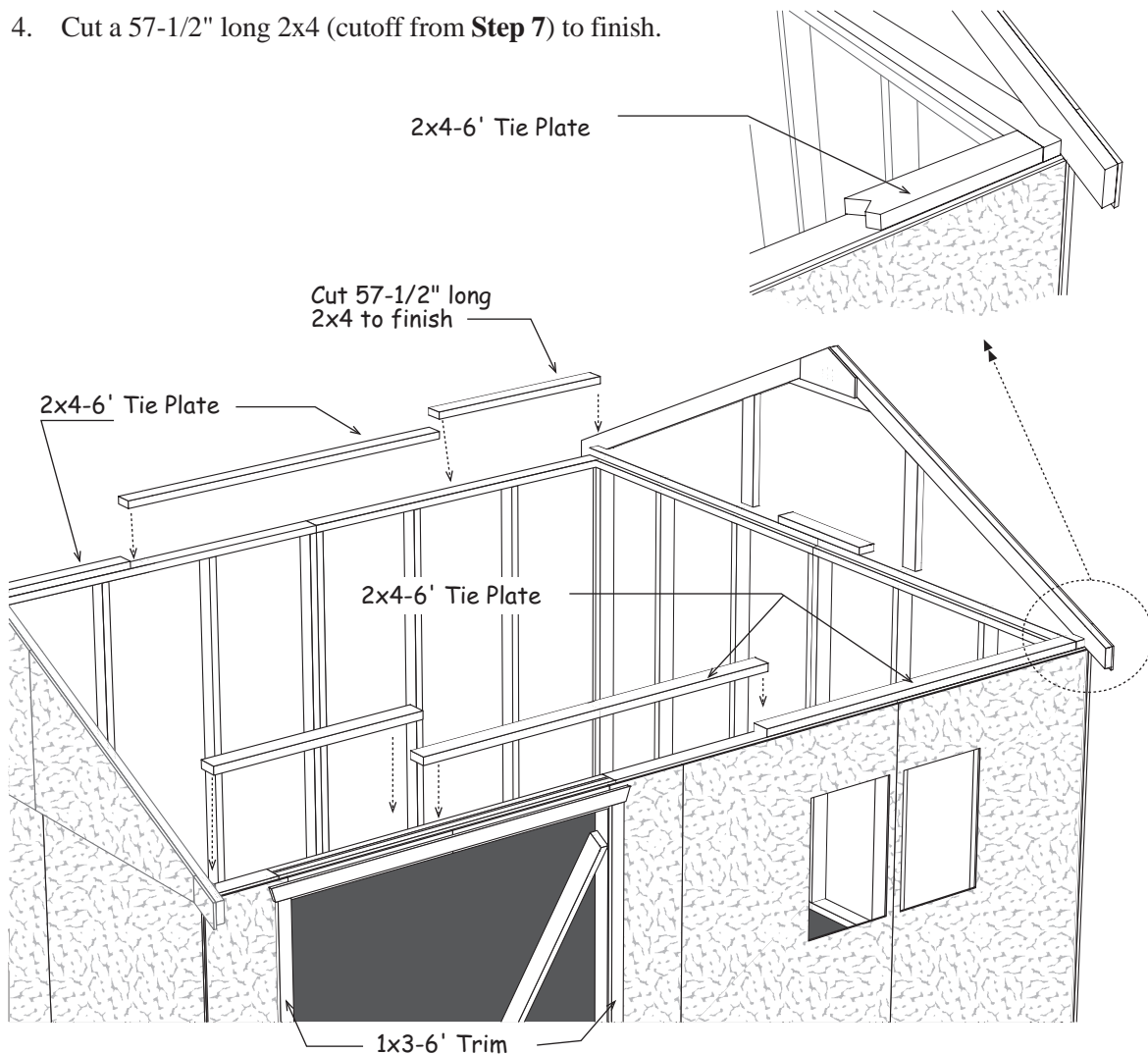

5. Install 1x3-6' boards along each side of the door opening, flush with the bottom edge of the siding. Tack these boards with a couple nails; you may want to move the trim later when you install the doors. Use 8d galv. nails.
6. Install a 1x3-6' board, across the top of the side trim.

Step 13 Layout Roof Trusses

1. Layout the truss spacing from the left sidewall of the building. Measure from the backside of the 2x4 gable frame when marking the location of the first truss. Continue 24" spacing to other gable. **Important:** When marking the opposite wall, place the 'X' mark on the same side of the line so your trusses are parallel when they are installed.
2. Install metal hangers to the tie plate with 6d common nails . The opening should line up with the 'X' mark, the bottom of the opening, flush with the 2x4 tie plate. **Detail 'D'**.

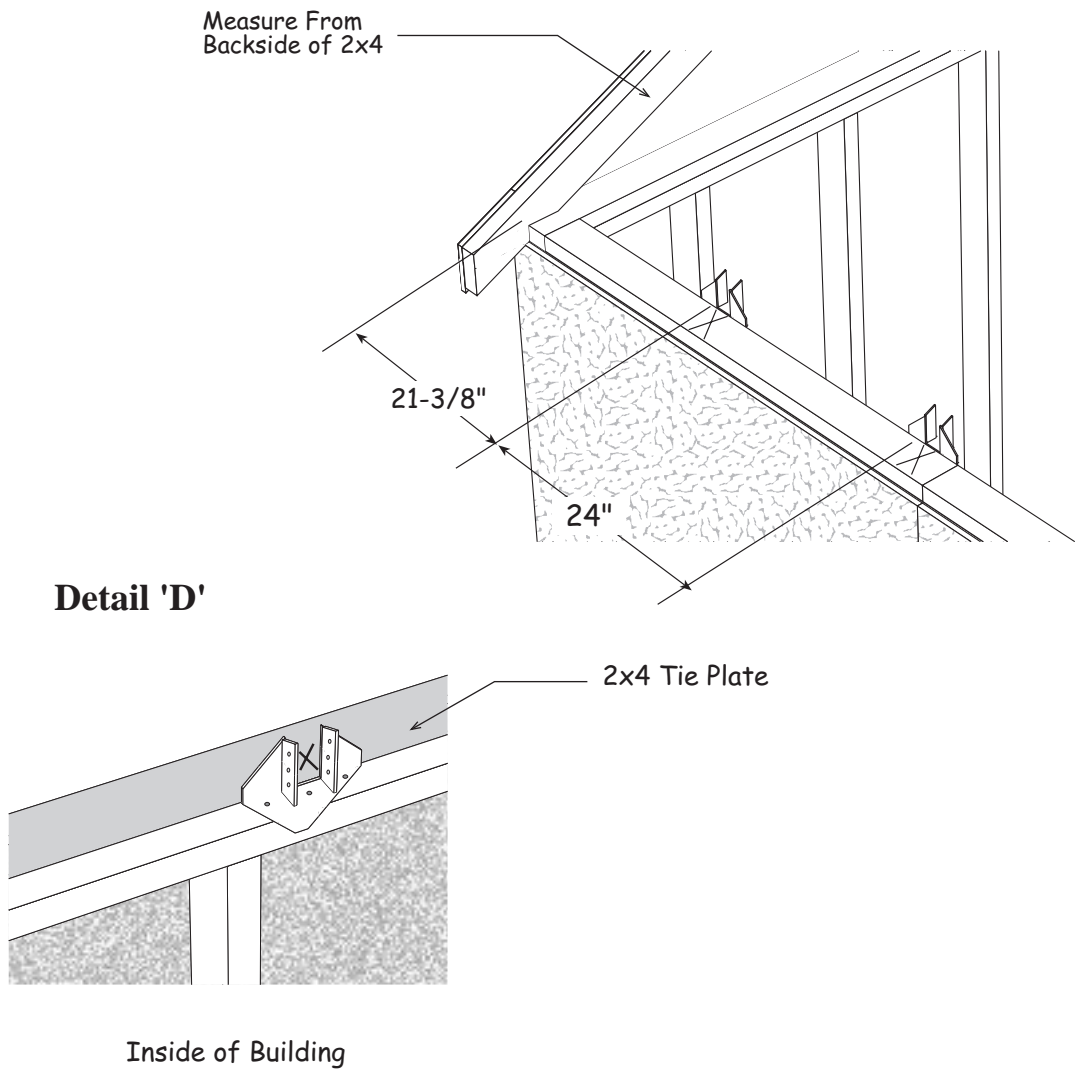

Step 14 Set Roof Trusses

Set roof trusses. Secure trusses to metal hangers with 6d common nails.

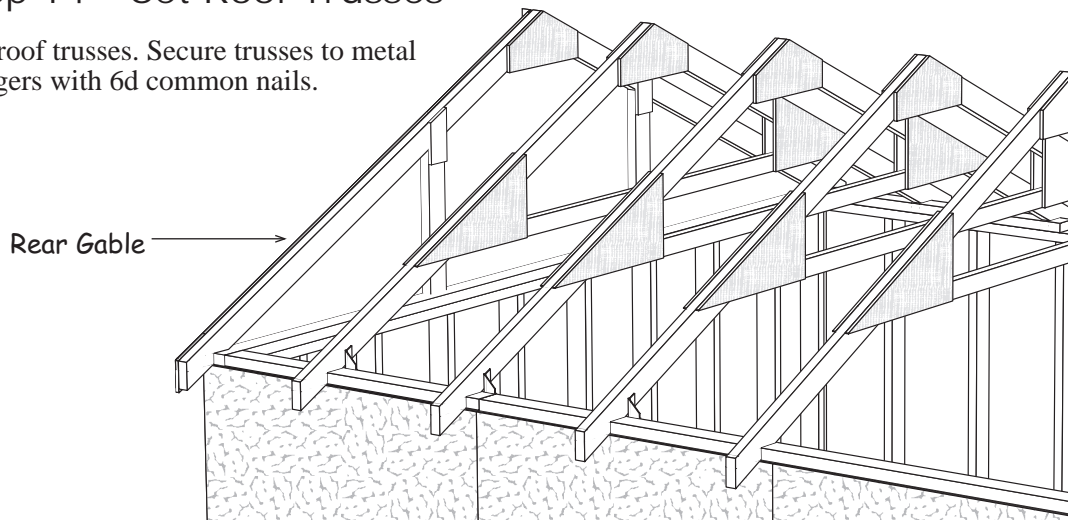

Step 15 Install Eave Soffit

1. Locate (4) four 5" x 48" primed siding pieces. Do not use 1x6 boards for this step. Starting from front left install soffit under the truss overhang. Install soffit with the beveled edge flush with the end of the trusses. Use 6d galv. nails.

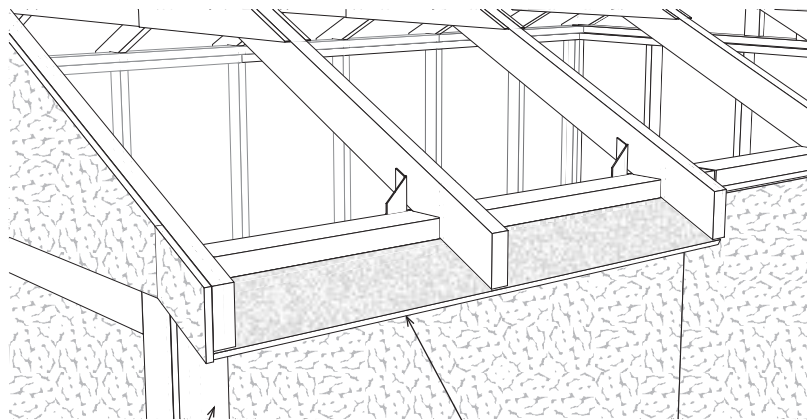

2. Cut 75-3/4' long 1x4 trim boards to length and install at the corners.
3. Repeat to install soffit and trim on back wall.

Soffit
Beveled Edge

Step 16 Install 1x6 Fascia & Roof Sheathing

1. Starting at the front left of the building, install 1x6-6' white pine fascia boards flush with the face of the siding on the end gable. Install the fascia so the bottom edge of the roof sheathing will rest on the beveled edge of the 1x6. Use a straight edge to align the 1x6 boards with the top of the trusses. Install fascia with 8d galv. nails.

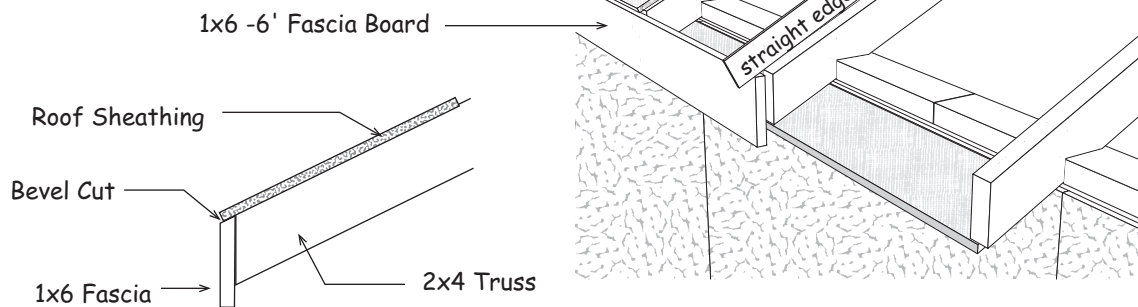

2. Install 1x6-6' fascia in the center of the building.
3. Cut to fit and install 1x6-4' fascia at the right end of the building.
4. Install roof sheathing per layout below. Make sure the trusses are plumb and the roof sheathing meets at the center of the truss. Use 7d sinkers spaced 12" apart. The top row of roof sheathing will be about 1" below the ridge to allow for ventilation.
5. Repeat on back of building to install fascia and roof sheathing.

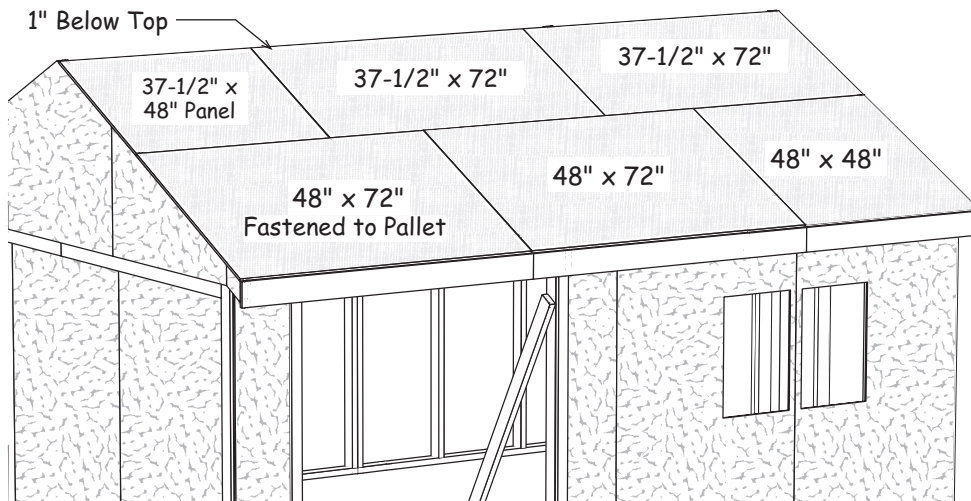

Step 17 Install Gable Trim

Install 1x6 gable trim flush with the top of the roof sheathing.

Use 8d galv. nails

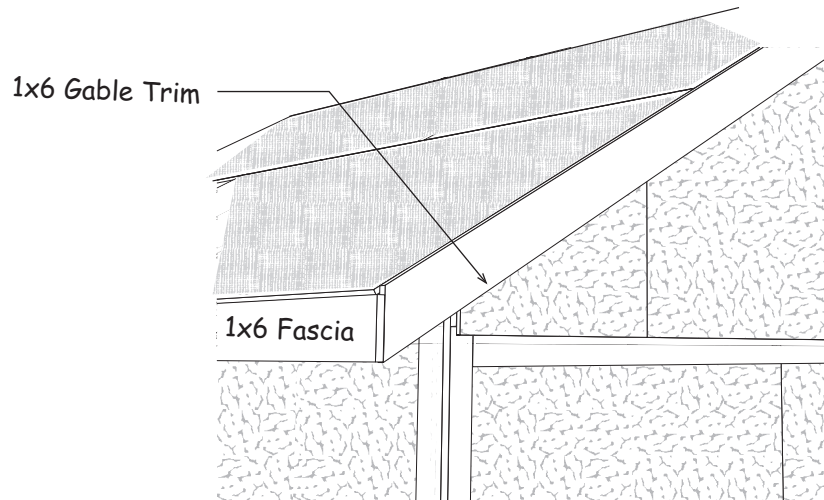

Step 18 Install Roofing — Not Supplied in Kit

1. Install metal roof edging perimeter of the roof area. If you are not installing shingles at this time, you can purchase felt paper to protect the roof sheathing. Install the felt paper before you install the metal roof edge.

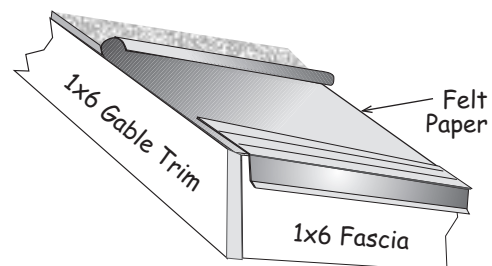

2. Install shingles according to the instructions on the wrapper. If you need more detailed instructions on installing shingles, there are good publications at book stores or newsstands.

Building Tip: Install ridge vent in lieu of shingles caps. Ridge vent provides ideal ventilation, preventing heat and moisture from damaging your building or its contents.

Optional ridge vent provides ideal ventilation.

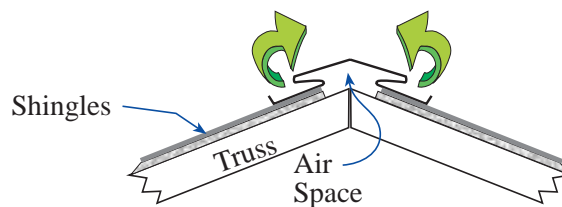

Step 18 Install Doors & Hardware

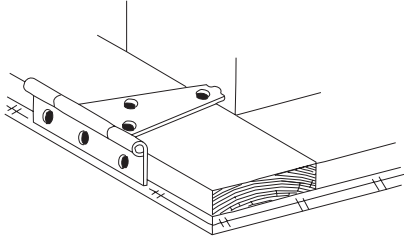

1. Lay the left door with the trim facing up. The siding on the left door extends past the door trim. See detail below.
2. Install 5" hinges to the left side of the door frame. To position the hinge properly, hold the rectangular plate against the frame. Use 1-3/4" black screws.
3. Install hinges to the right side of the other door.

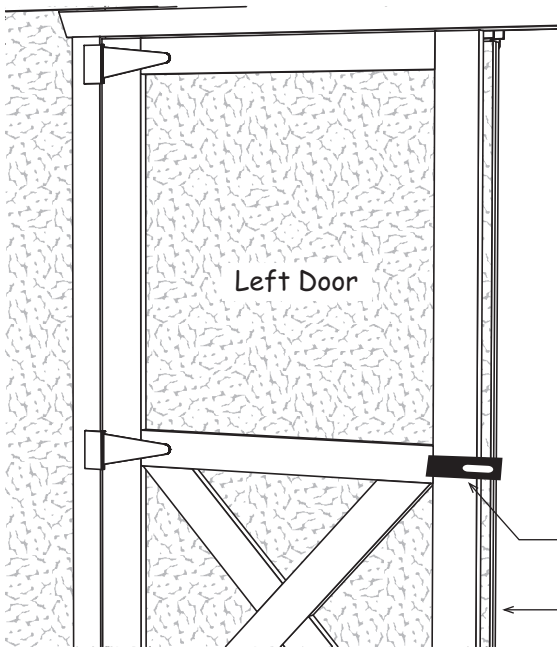

4. Before you fasten the hinges to the door trim, temporarily prop the doors in the opening. Leave a space at the top of the doors and between the doors and the side trim to allow room for the doors to expand when they absorb moisture.

If your door opening is out of square, the space around the doors will not be even. You can remove and reposition the side trim to make allowances for this. The side trim does not have to be flush with the frame of the door opening. You can move the trim in or out to make the door spacing equal.

5. Install hinges to trim with 2" screws.

Barrel Bolt on the back of left door

6. Install a barrel bolt on the lower back of the door to secure this door in place when closed. You will need to drill a hole for the round shaft to drop into.
7. Install another barrel bolt at the top of the door.

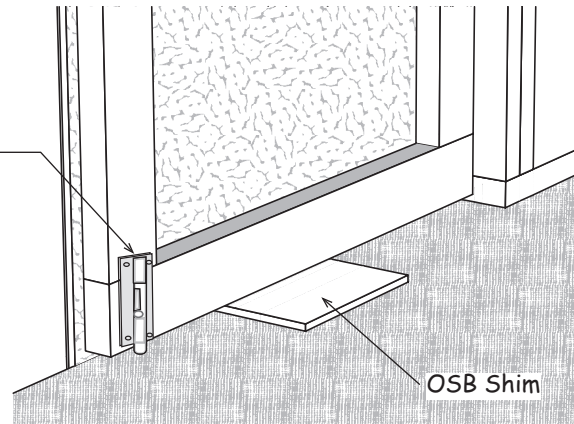

Material Packaged In Component Kit

7	2x4 for Collar Ties		90"	3	1 lb. box	10d	Sinkers
18	2x4 for Truss Rafters		86-1/4"	3	1 lb. box	8d	Galv.
4	2x4 (<i>on pallet</i>) for Wall Bracing		76"	2	1 lb. box	7d	Sinkers
52	2x4 for Wall Studs & Plates		72"	1	1 lb. box	6d	Galv.
8	2x4 for Wall Plates		68-1/2"	1	5 lb. box	6d	Common
2	2x4 for Door Header		67-1/2"	6	ea.	5"	Door Hinges
2	2x4 for Wall Plates		62"	1	ea.	4.5"	Door Latch
4	2x4 for Wall Plates		45"	2	ea.	6"	Barrel Bolts
4	2x4 for Gable Studs		23-1/2"	48	ea.	2"	Hinge Screws
8	2x4 for Truss Jig Blocks		10"	6	ea.	1x4	Metal Plates
14	Truss Gussets	7/16"	8" x 20"	2	ea.		Bottle Glue
28	Truss Gussets	7/16"	12" x 24"	4	ea.	1x6 Gable Trim	87"
8	Soffit Boards	3/8"	5" x 48"	4	ea.	1x6 Fascia Trim	72"
2	Plywood Gusset	3/4"	3.5" x 32"	2	ea.	1x6 Fascia Trim	48-1/2"
14	2x4 Metal Truss Hangers			4	ea.	1x4 Corner Trim	75-3/4"
2	ea	Pre-built Doors	32" x 71-3/4"	4	ea.	1x3 Corner Trim	75-3/4"
LP Primed Exterior Siding				4	ea.	1x4 Wall Trim	72"
12	ea	Siding Panels	48" x 75-1/4"	3	ea.	1x3 Door Trim	72"
2	ea	Siding Panels	16" x 75-1/4"	Roof Sheathing			
<i>Siding Angled Cut For Roof Gables</i>				4	ea.	Sheathing 7/16"	48' x 72'
2	ea	Siding Panels	48" x 40"	2	ea.	Sheathing 7/16"	48' x 48'
4	ea	Siding Panels	48" x 28"	4	ea.	Sheathing 7/16"	37-1/2' x 72"
				2	ea.	Sheathing 7/16"	37-1/2' x 48"

Roof Covering - not supplied in kit

9	bdl.	Roof Shingles	
8	pcs.	Roof 'drip' Edge	10'