

## Obtaining a permit for a Best Barns shed or garage kit

*Do-it-Yourself kits from Best Barns are designed for use as storage buildings or garages only. Use for any other purposes is neither implied nor inferred.\**

Building code offices and HOA's may require additional documents to obtain a permit. The homeowner's first step is to contact their local code office and ask what is needed for the size of building to be purchased.

Typically, the necessary documentation may include some or all of the following.

- o Elevations showing at least two sides of structure.
- o Site plan showing existing structures and proposed build site.
- o Engineered drawings for truss system indicating snow and wind load ratings.\*\*
- o Cross sections of wall framing and foundation.
- o Tie down locations for high wind load areas.\*\*\*

Permit requirements vary based on location. Some areas may not require a permit at all. The documents provided by Best Barns are intended to help the homeowner with the permit process but do not guarantee a permit will be issued. It is the homeowner's responsibility to determine if a permit is required and submit the necessary documentation.

\*Any alteration to the construction of Best Barns sheds or garages may require the services of a civil engineer to meet local building codes. Best Barns cannot provide these additional services.

\*\* Engineered truss drawings stamped for your individual state can be obtained upon request. Some models do not have wind and snow load ratings. A non refundable fee will be required to purchase stamped drawings. Contact us directly at 800-245-1577 for further details.

\*\*\* Certain states such as Florida and California have stringent requirements for obtaining a permit. Depending on your location, a civil engineer's services may be required to provide necessary documents. These services are the homeowner's responsibility to obtain from an engineer within the state of build location and are not included in the purchase of a shed or garage kit.

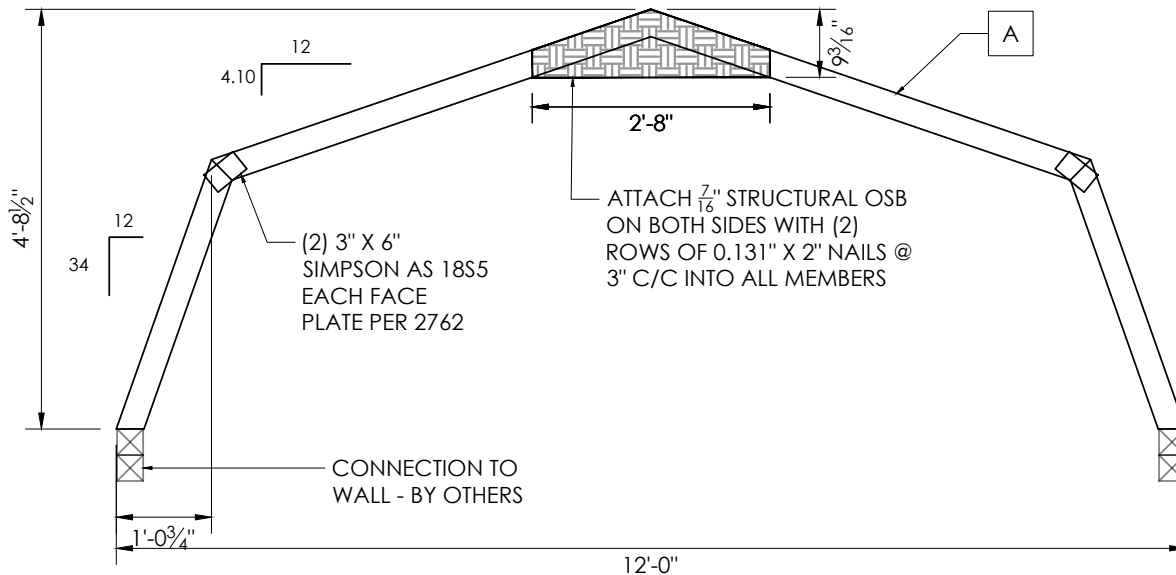

DESIGN BY / CHECKED BY:  
A.W. / O.A.

PROJECT NO.:  
476-23-0575

CUSTOMER:  
BEST BARN

TITLE:  
TIMBER TRUSS

STATE:  
XX - XXXXXXXXXXXX

DATE:  
01/24/2024

**DESIGN CRITERIA**

INTERNATIONAL BUILDING CODE  
IBC 2021, IBC 2018, IBC 2015 DESIGN CRITERIA :

DEAD LOAD (D):

ROOF COLLATERAL DEAD LOAD 2.5 PSF

LIVE LOAD (Lr):

ROOF LIVE LOAD 20 PSF

SNOW LOAD (S):

GROUND SNOW LOAD 40 PSF  
SNOW LOAD IMPORTANCE FACTOR (Is) 1.0  
EXPOSURE FACTOR (Ce) 1.0  
THERMAL FACTOR (Ct) 1.0  
GOVERNING ROOF SNOW LOAD 28 PSF

UNBALANCED SNOW LOAD 40 PSF

WIND (W):

ANALYSIS PROCEDURE: ASCE 7-10 / ASCE 7-16  
BASIC WIND SPEED: 115 MPH  
EXPOSURE CATEGORY: C

LOAD COMBINATIONS:

- 1.0 D
- 1.0 D + 1.0 L
- 1.0 D + 1.0 (Lr or S)
- 1.0 D + 0.75 L + 0.75 (Lr or S)
- 1.0 D + (0.6 W)
- 1.0 D + 0.75 (1.0 W) + 0.75 L + 0.75 (Lr or S)
- 0.6 D + 1.0 W

**DESIGN DETAILS**

A - TOP CHORD	2X4
B - BOTTOM CHORD	-
C - WEB	-
D - COLLAR-TIE	-
SPACING	24" C/C
WOOD MATERIAL	SPF NO. 2
MAX. UNBRACED LENGTH OF TOP CHORD	5'-11 7/8"
DEAD LOAD DEFLECTION	L / 180
LIVE LOAD DEFLECTION	L / 240
DEAD + LIVE LOAD DEFLECTION	L / 180
UPLIFT REACTION AT CONN. TO WALL (LBF)	44
LATERAL REACTION AT CONN. TO WALL (LBF)	208
BEARING REACTION AT CONN. TO WALL (LBF)	355

**WOOD DESIGN NOTES:**

C <sub>D</sub> - LOAD DURATION FACTOR FOR WIND	1.6
C <sub>D</sub> - LOAD DURATION FACTOR FOR SNOW	1.15
C <sub>M</sub> - MOISTURE CONTENT	1.0
C <sub>t</sub> - TEMPERATURE FACTOR	1.0

NOTES:

1. UNBALANCED SNOW LOADS HAVE BEEN CONSIDERED IN THE DESIGN.
2. WIND LOADING IS BASED ON 3-S GUST ULTIMATE WIND SPEED, EXPOSURE C, PER ASCE 7.
3. LOADS ARE BASED ON RISK CATEGORY II.
4. SEE ADDITIONAL SHEETS FOR MEMBER CHECKS.

**CERTIFICATION EXPIRY:** XX/XX/XXXX  
**STAMP DATE EXPIRES:** XX/XX/XXXX  
**DATE SIGNED:** XX/XX/XXXX



Before you order our kit or begin construction, obtain a building permit. If additional documents are required contact [questions@barnkits.com](mailto:questions@barnkits.com).

## ELEVATION

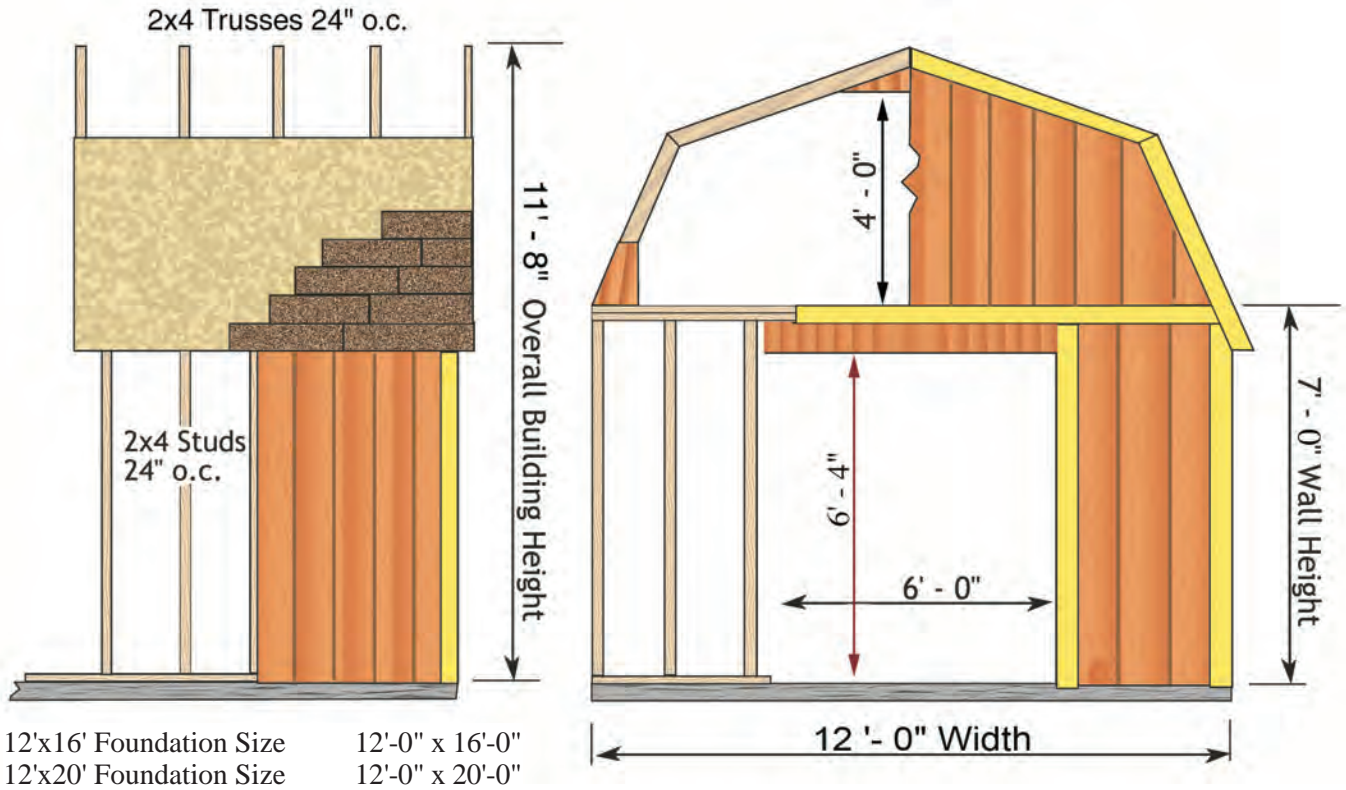

**Wall Framing:** 2x4 Construction with 24" on center stud spacing, single bottom plate and top plate with 2x4 tie plates.

**2nd Loft Floor:** Loft floor on each end with a 4' wide access opening between loft sections.

**Siding:** Louisiana-Pacific 'SmartPanel' 8" o.c. groove, primed ready to paint

**Floor:** Sold optionally

**Roof System:** 2x4 trusses spaced 24" on center, (see engineered truss drawing for load ratings). 7/16" OSB roof sheathing. *Shingles by owner.*

**Exterior Trim:** White pine trim for corners, door, gable trim and front and back fascia. Primed ready to paint.

**Hardware:** Nails for all framing, door hardware and metal hurricane hangers for trusses included.

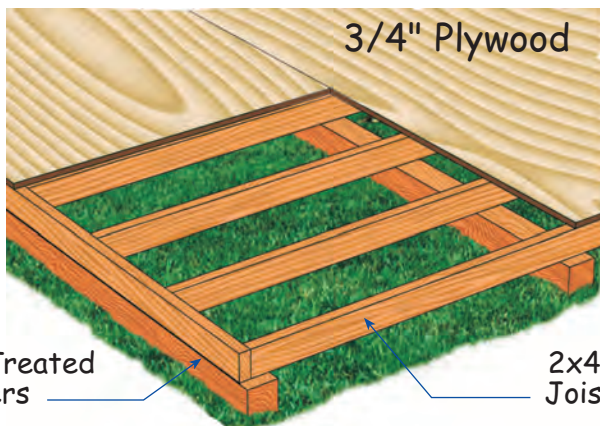

**Deluxe Floor (optional accessory):** 4x4 treated runners can be installed directly on the grass. The runners elevate the floor providing air flow eliminating moisture. 12' wide floor has four runners. Floor covering is 3/4" plywood.

12ft. wide x \_\_\_ft. long

Manufactured by:  
RBS Holdings, LLC.  
205 Arlington Drive  
Greenville, PA 16125  
phone: 800-245-1577  
fax: 724-646-0772

### Common Foundation Cross Sections

This document illustrates common foundation types which can be used for construction of Best Barns 12 ft. wide structures. Alteration may be necessary to conform to homeowners intended use and or permitting requirements.

Drawings not to scale.

#### Instructions:

Check appropriate foundation cross section and provide specifications as necessary.

Homeowner may also design and draw in space provided for custom foundation type.

#### Concrete Slab

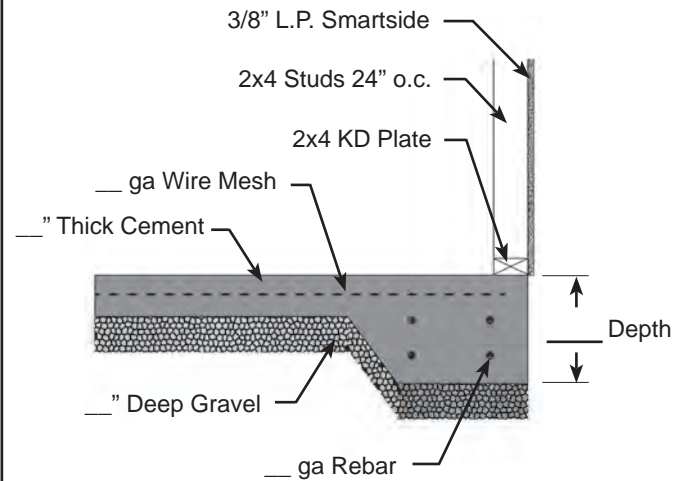

#### Wood Floor

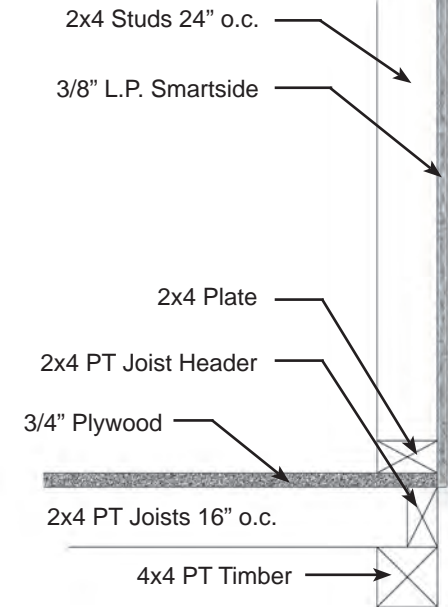

#### Homeowner Design

12ft. wide x \_\_\_ft. long

Manufactured by:  
RBS Holdings, LLC.  
205 Arlington Drive  
Greenville, PA 16125  
phone: 800-245-1577  
fax: 724-646-0772

### Truss & Wall Cross Section

Top of wall inclusive of wall framing, loft floor, floor joists, joist header and truss cross sections.

Drawing not to scale.

#### Instructions:

Homeowner may provide additional information as appropriate.

#### Notes:

Refer to installation manual for further detail.

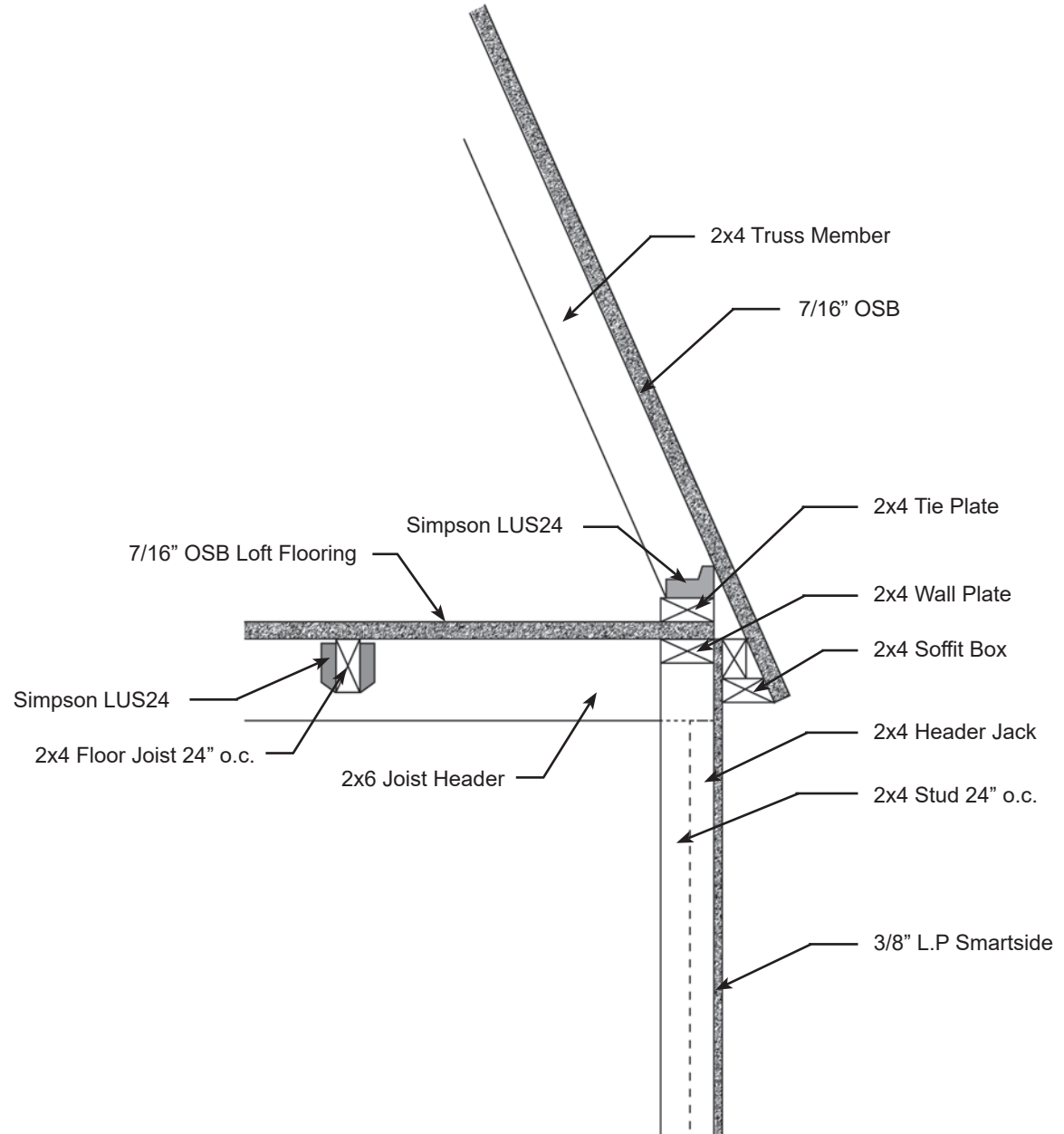

**Site Plan for:**

Manufactured by:

RBS Holdings, LLC.

205 Arlington Drive

Greenville, PA 16125

phone: 800-245-1577

fax: 724-646-0772

**Instructions:**

Draw property line, existing structures and proposed placement of building.

Homeowner may also be required to show trees and shrubs. Check with HOA or permit office for requirements.

A large, empty rectangular box with a black border, intended for the site plan drawing. It occupies the right two-thirds of the page.