

Obtaining a permit for your Best Barns shed or garage kits

*Do-it-Yourself kits from Best Barns are designed for use as storage buildings or garages only. Use for any other purposes is neither implied nor inferred.**

Building code offices and HOA's may require additional documents to obtain a permit. The homeowner's first step is to contact their local code office and ask what is needed for the size of building to be purchased.

Typically, the necessary documentation may include some or all of the following.

- o Elevations showing at least two sides of structure.
- o Site plan showing existing structures and proposed build site.
- o Engineered drawings for truss system indicating snow and wind load ratings.**
- o Cross sections of wall framing and foundation.
- o Tie down locations for high wind load areas.***

Permit requirements vary based on location. Some areas may not require a permit at all. The documents provided by Best Barns are intended to help the homeowner with the permit process but do not guarantee a permit will be issued. It is the homeowner's responsibility to determine if a permit is required and submit the necessary documentation.

*Any alteration to the construction of Best Barns sheds or garages may require the services of a civil engineer to meet local building codes. Best Barns cannot provide these additional services.

** Engineered truss drawings stamped for your individual state can be obtained upon request. Some models do not have wind and snow load ratings. A deposit will be required if the shed or garage kit has not yet been purchased. Contact us directly at 800-245-1577 for further details.

*** Certain states such as Florida and California have stringent requirements for obtaining a permit. Depending on your location, a civil engineer's services may be required to provide necessary documents. These services are the homeowner's responsibility to obtain and are not included in the purchase of a shed or garage kit.



Before you order our kit or begin construction, obtain a building permit. If additional documents are required contact questions@barnkits.com.

Cypress Elevation

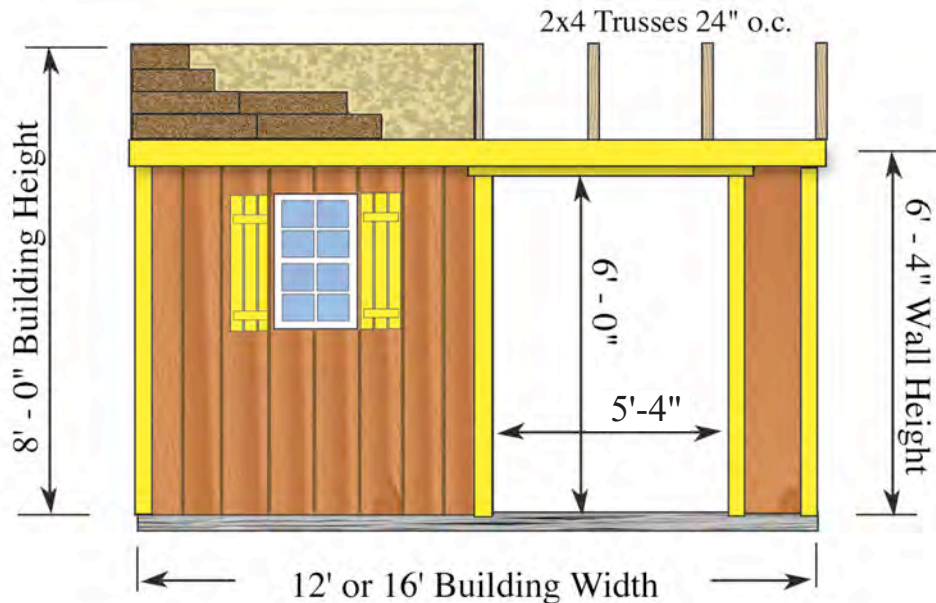

Foundation: By owner

Wall Framing: Constructed from 2x4 pre-cut wall studs spaced 24" on center between top and bottom plates.

Siding: Louisiana-Pacific 'Smart Panel' primed 8" o.c. groove with 50 year warranty, 5 year labor replacement. Siding is pre-cut for fast and accurate field assembly.

Roof System: 2x4 trusses spaced 24" on center, covered with pre-cut 7/16" OSB roof sheathing. *Shingles by owner.*

Exterior Trim: White pine trim for corners, door and gable trim. Doors are pre-built

Hardware: Nails for all framing and door hardware included. Windows are optional and extra.

Optional Floor: is constructed with treated 2x4 framing. Floor joists are spaced 16" on center and covered with 5/8" OSB (oriented strand board).

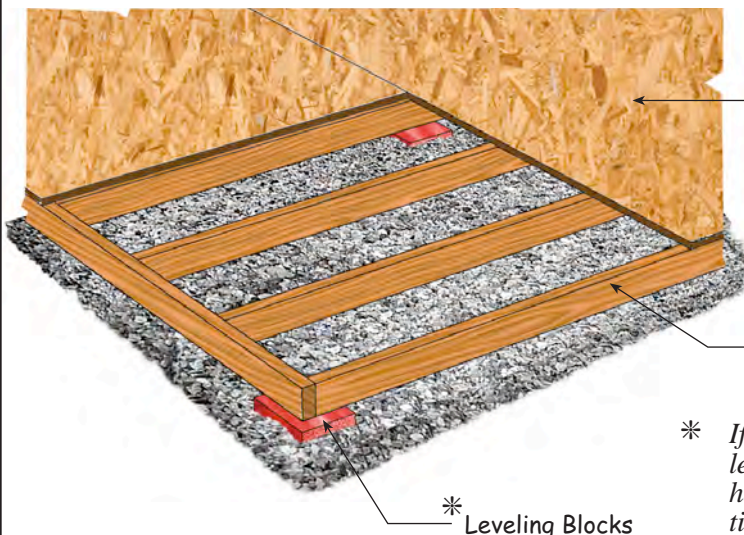

Foundation Size

12'x10'12'-0" long x 10'-0" deep

16'x10'16'-0" long x 10'-0" deep

2x4 Treated Joist 16" o.c.

* Leveling Blocks

* If necessary use bricks, patio stones or similar material to level or provide additional support to the floor. If your ground has low areas consider adding gravel and or 4x4 treated timbers to rest the floor on.

Best Barns model: _____
 ___ft. wide x ___ft. long

Manufactured by:
 Reynolds Building Systems, Inc.
 205 Arlington Drive
 Greenville, PA 16125
 phone: 800-245-1577
 fax: 724-646-0772

Common Foundation Cross Sections

This document illustrates common foundation types which can be used for construction of Best Barns 10 ft. wide structures. Alteration may be necessary to conform to homeowners intended use and or permitting requirements.
 Drawings not to scale.

Instructions:

Check appropriate foundation cross section and provide specifications as necessary.
 Homeowner may also design and draw in space provided for custom foundation type.

Concrete Slab

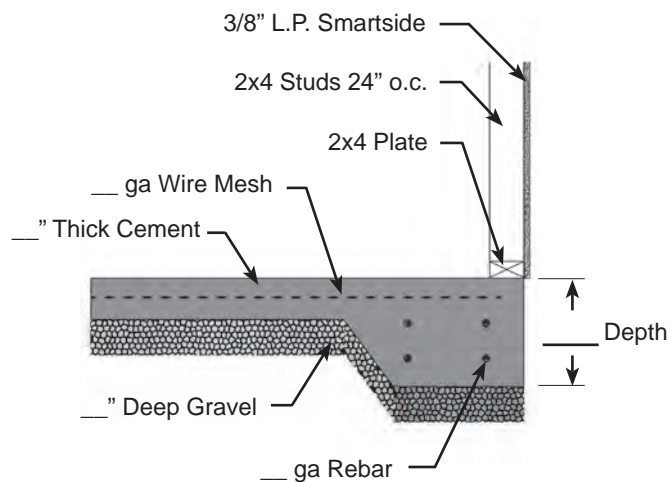

Homeowner Design

Wood Floor

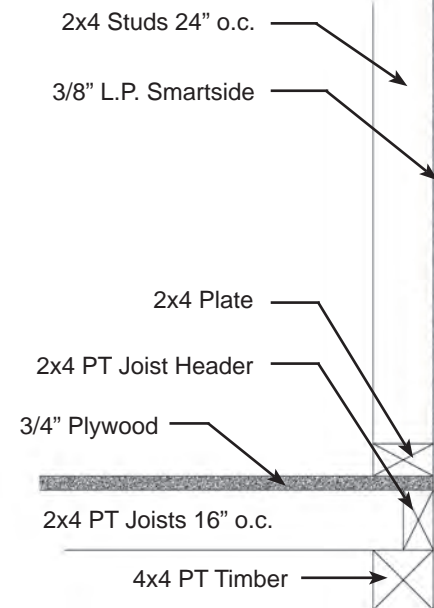

Site Plan for:

Manufactured by:
Reynolds Building Systems, Inc.
205 Arlington Drive
Greenville, PA 16125
phone: 800-245-1577
fax: 724-646-0772

Instructions:

Draw property line, existing structures and proposed placement of building.

Homeowner may also be required to show trees and shrubs. Check with HOA or permit office for requirements.

A large, empty rectangular box with a black border, intended for the site plan drawing. It occupies the right two-thirds of the page.