

Obtaining a permit for a Best Barns shed or garage kit

*Do-it-Yourself kits from Best Barns are designed for use as storage buildings or garages only. Use for any other purposes is neither implied nor inferred.**

Building code offices and HOA's may require additional documents to obtain a permit. The homeowner's first step is to contact their local code office and ask what is needed for the size of building to be purchased.

Typically, the necessary documentation may include some or all of the following.

- o Elevations showing at least two sides of structure.
- o Site plan showing existing structures and proposed build site.
- o Engineered drawings for truss system indicating snow and wind load ratings.**
- o Cross sections of wall framing and foundation.
- o Tie down locations for high wind load areas.***

Permit requirements vary based on location. Some areas may not require a permit at all. The documents provided by Best Barns are intended to help the homeowner with the permit process but do not guarantee a permit will be issued. It is the homeowner's responsibility to determine if a permit is required and submit the necessary documentation.

*Any alteration to the construction of Best Barns sheds or garages may require the services of a civil engineer to meet local building codes. Best Barns cannot provide these additional services.

** Engineered truss drawings stamped for your individual state can be obtained upon request. Some models do not have wind and snow load ratings. A non refundable fee will be required to purchase stamped drawings. Contact us directly at 800-245-1577 for further details.

*** Certain states such as Florida and California have stringent requirements for obtaining a permit. Depending on your location, a civil engineer's services may be required to provide necessary documents. These services are the homeowner's responsibility to obtain from an engineer within the state of build location and are not included in the purchase of a shed or garage kit.

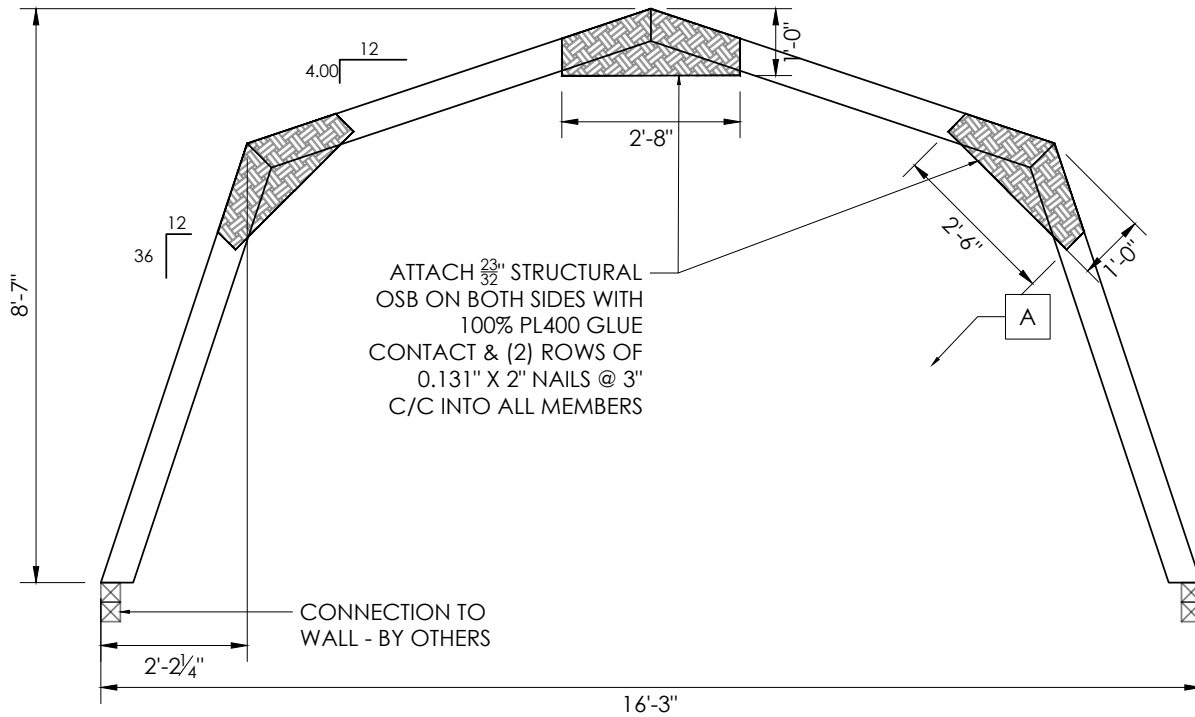

DESIGN CRITERIA

INTERNATIONAL BUILDING CODE
IBC 2021, IBC 2018, IBC 2015 DESIGN CRITERIA

DEAD LOAD (D):

ROOF COLLATERAL DEAD LOAD 2.5 PSF

LIVE LOAD (Lr):

ROOF LIVE LOAD 20 PSF

SNOW LOAD (S):

GROUND SNOW LOAD 45 PSF
SNOW LOAD IMPORTANCE FACTOR (Is) 1.0
EXPOSURE FACTOR (Ce) 1.0
THERMAL FACTOR (Ct) 1.1
GOVERNING ROOF SNOW LOAD 34.65 PSF

UNBALANCED SNOW LOAD 45 PSF

WIND (W):

ANALYSIS PROCEDURE: ASCE 7-10 / ASCE 7-16
BASIC WIND SPEED: 130 MPH
EXPOSURE CATEGORY: C

LOAD COMBINATIONS:

1.0 D
1.0 D + 1.0 L
1.0 D + 1.0 (Lr or S)
1.0 D + 0.75 L + 0.75 (Lr or S)
1.0 D + (0.6 W)
1.0 D + 0.75 (1.0 W) + 0.75 L + 0.75 (Lr or S)
0.6 D + 1.0 W

NOTES:

- UNBALANCED SNOW LOADS HAVE BEEN CONSIDERED IN THE DESIGN.
- WIND LOADING IS BASED ON 3-S GUST ULTIMATE WIND SPEED, EXPOSURE C, PER ASCE 7.
- LOADS ARE BASED ON RISK CATEGORY II.
- SEE ADDITIONAL SHEETS FOR MEMBER CHECKS.

DESIGN DETAILS

A - TOP CHORD	2X6
B - BOTTOM CHORD	-
C - WEB	2X4
D - COLLAR-TIE	-
SPACING	24" C/C
WOOD MATERIAL	SPF NO. 2
MAX. UNBRACED LENGTH OF TOP CHORD	3'-3 $\frac{3}{16}$ "
DEAD LOAD DEFLECTION	L / 180
LIVE LOAD DEFLECTION	L / 240
DEAD + LIVE LOAD DEFLECTION	L / 180
UPLIFT REACTION AT CONN. TO WALL (LBF)	135
LATERAL REACTION AT CONN. TO WALL (LBF)	285
BEARING REACTION AT CONN. TO WALL (LBF)	598

WOOD DESIGN NOTES:

C _D - LOAD DURATION FACTOR FOR WIND	1.6
C _D - LOAD DURATION FACTOR FOR SNOW	1.15
C _M - MOISTURE CONTENT	1.0
C _t - TEMPERATURE FACTOR	1.0

CERTIFICATION EXPIRY: XX/XX/XXXX
STAMP DATE EXPIRES: XX/XX/XXXX
DATE SIGNED: XX/XX/XXXX

DESIGN BY / CHECKED BY: A.W. / O.A.
PROJECT NO.: 476-23-0575
CLIENT: BEST BARNS
TITLE: TIMBER TRUSS
STATE: XX - XXXXXXXXXXXX
DATE: 01/24/2024

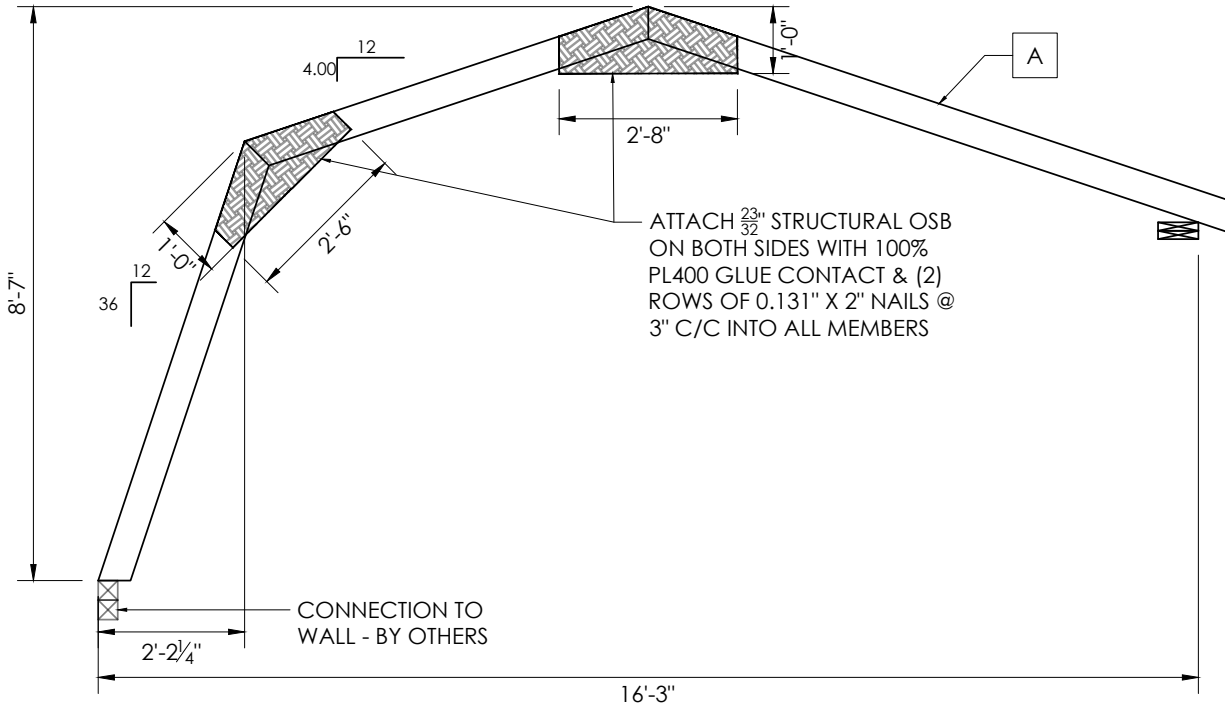

DESIGN BY / CHECKED BY:
A.W. / O.A.

PROJECT NO.:
476-23-0575

CLIENT:
BEST BARNS

TITLE:
TIMBER TRUSS

STATE:
XX - XXXXXXXXXXXX

DATE:
01/24/2024

DESIGN CRITERIA

INTERNATIONAL BUILDING CODE
IBC 2021, IBC 2018, IBC 2015 DESIGN CRITERIA

DEAD LOAD (D):

ROOF COLLATERAL DEAD LOAD 2.5 PSF

LIVE LOAD (Lr):

ROOF LIVE LOAD 20 PSF

SNOW LOAD (S):

GROUND SNOW LOAD 45 PSF
SNOW LOAD IMPORTANCE FACTOR (Is) 1.0
EXPOSURE FACTOR (Ce) 1.0
THERMAL FACTOR (Ct) 1.1
GOVERNING ROOF SNOW LOAD 34.65 PSF

UNBALANCED SNOW LOAD 45 PSF

WIND (W):

ANALYSIS PROCEDURE: ASCE 7-10 / ASCE 7-16
BASIC WIND SPEED: 130 MPH
EXPOSURE CATEGORY: C

LOAD COMBINATIONS:

- 1.0 D
- 1.0 D + 1.0 L
- 1.0 D + 1.0 (Lr or S)
- 1.0 D + 0.75 L + 0.75 (Lr or S)
- 1.0 D + (0.6 W)
- 1.0 D + 0.75 (1.0 W) + 0.75 L + 0.75 (Lr or S)
- 0.6 D + 1.0 W

NOTES:

1. UNBALANCED SNOW LOADS HAVE BEEN CONSIDERED IN THE DESIGN.
2. WIND LOADING IS BASED ON 3-S GUST ULTIMATE WIND SPEED, EXPOSURE C, PER ASCE 7.
3. LOADS ARE BASED ON RISK CATEGORY II.
4. SEE ADDITIONAL SHEETS FOR MEMBER CHECKS.

DESIGN DETAILS

A - TOP CHORD	2X6
B - BOTTOM CHORD	-
C - WEB	-
D - COLLAR-TIE	-
SPACING	24" C/C
WOOD MATERIAL	SPF NO. 2
MAX. UNBRACED LENGTH OF TOP CHORD	4'-10 7/8"
DEAD LOAD DEFLECTION	L / 180
LIVE LOAD DEFLECTION	L / 240
DEAD + LIVE LOAD DEFLECTION	L / 180
UPLIFT REACTION AT CONN. TO WALL (LBF)	332
LATERAL REACTION AT CONN. TO WALL (LBF)	264
BEARING REACTION AT CONN. TO WALL (LBF)	566

WOOD DESIGN NOTES:

C _D - LOAD DURATION FACTOR FOR WIND	1.6
C _D - LOAD DURATION FACTOR FOR SNOW	1.15
C _M - MOISTURE CONTENT	1.0
C _t - TEMPERATURE FACTOR	1.0

CERTIFICATION EXPIRY: XX/XX/XXXX
STAMP DATE EXPIRES: XX/XX/XXXX
DATE SIGNED: XX/XX/XXXX

$\frac{23}{32}$ " T&G OSB SUBFLOOR
 CONNECT OSB SUBFLOOR MIN. 4'-0"
 WIDTH TO FLOOR JOIST WITH 1 ROW OF
 #10 X 3" NAILS @ 4" C/C @ BLOCKING
 LOCATIONS & 6" C/C ELSEWHERE

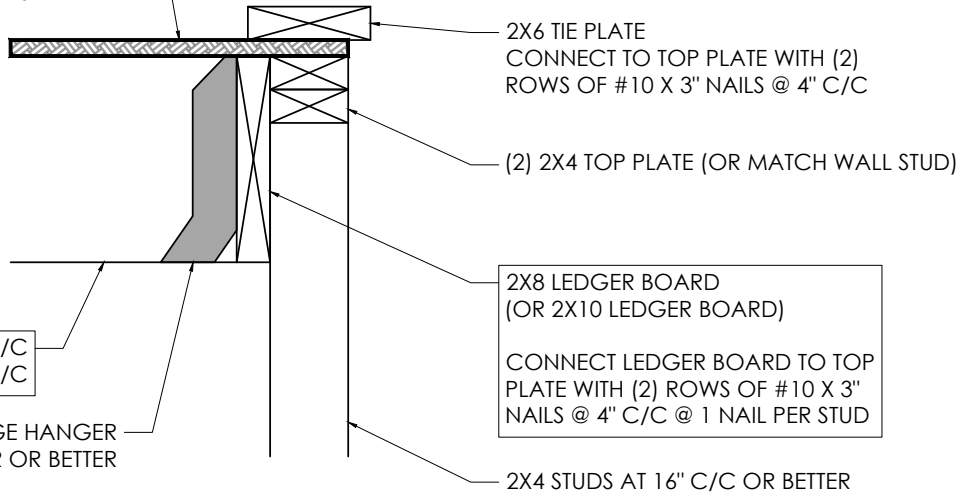

2X8 DF-LAR. NO. 1 @ 12" C/C
 2X10 DF-LAR. NO. 1 @ 16" C/C

2X8 TOP FLANGE HANGER
 OR SIMPSON LU24 HANGER OR BETTER

2X6 TIE PLATE
 CONNECT TO TOP PLATE WITH (2)
 ROWS OF #10 X 3" NAILS @ 4" C/C

(2) 2X4 TOP PLATE (OR MATCH WALL STUD)

2X8 LEDGER BOARD
 (OR 2X10 LEDGER BOARD)
 CONNECT LEDGER BOARD TO TOP
 PLATE WITH (2) ROWS OF #10 X 3"
 NAILS @ 4" C/C @ 1 NAIL PER STUD

2X4 STUDS AT 16" C/C OR BETTER

DESIGN BY / CHECKED BY:
 A.W. / O.A.

PROJECT NO.:
 476-23-0575

CLIENT:
 BEST BARN

TITLE:
 TIMBER FLOOR

STATE:
 XX - XXXXXXXXXXXX

DATE:
 01/24/2024

DESIGN CRITERIA

INTERNATIONAL BUILDING CODE
 IBC 2021, IBC 2018, IBC 2015 DESIGN CRITERIA

DEAD LOAD (D):

FLOOR COLLATERAL DEAD LOAD 10 PSF

ATTIC FLOOR LIVE LOAD (L):

FLOOR LIVE LOAD - 2X8 30 PSF
 FLOOR LIVE LOAD - 2X10 40 PSF

LOAD COMBINATIONS:

1.0 D
 1.0 D + 1.0 L

DESIGN DETAILS

MAX. UNBRACED LENGTH OF TOP CHORD	16'-0"
DEAD LOAD DEFLECTION	L / 180
LIVE LOAD DEFLECTION	L / 240
DEAD + LIVE LOAD DEFLECTION	L / 180

WOOD DESIGN NOTES:

C _D - LOAD DURATION FACTOR FOR WIND	1.6
C _D - LOAD DURATION FACTOR FOR SNOW	1.15
C _M - MOISTURE CONTENT	1.0
C _t - TEMPERTATURE FACTOR	1.0

NOTES:

- BLOCKING TO BE PROVIDED EVERY 4'-0" C/C MAX.
- MAX. FLOOR JOIST SPAN IS 16'-0".

CERTIFICATION EXPIRY: XX/XX/XXXX
 STAMP DATE EXPIRES: XX/XX/XXXX
 DATE SIGNED: XX/XX/XXXX

Cross Section 16' Wide Buildings

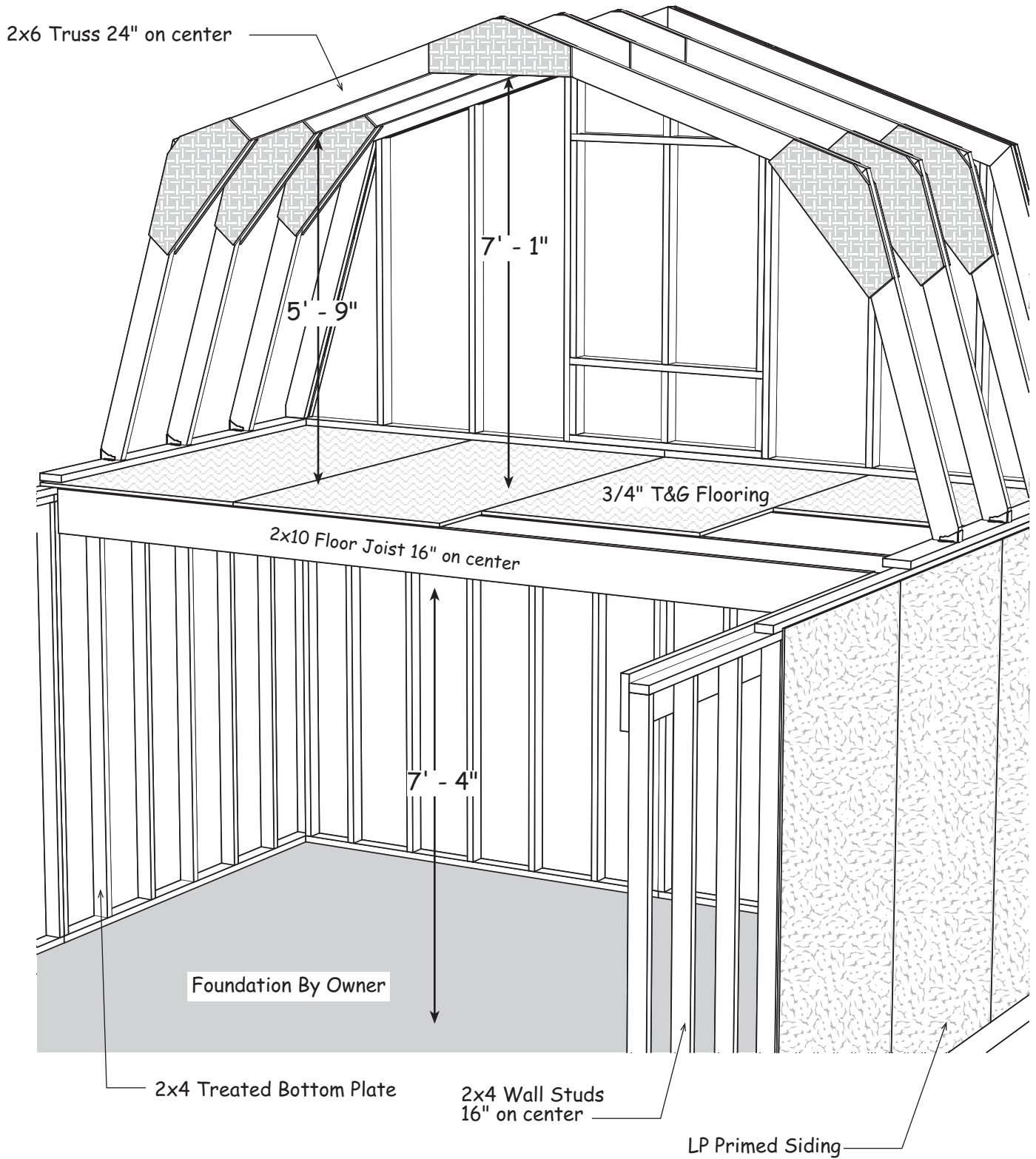

16ft. wide x ___ft. long
2 Story Gambrel Building

Manufactured by:
RBS Holdings, LLC.
205 Arlington Drive
Greenville, PA 16125
phone: 800-245-1577
fax: 724-646-0772

Truss & Wall Cross Section

Top of wall inclusive of loft floor joists, Subfloor, wall framing and truss cross sections.

Drawing not to scale.

Instructions:

Homeowner may provide additional information as appropriate.

Notes:

Refer to installation manual for further detail.

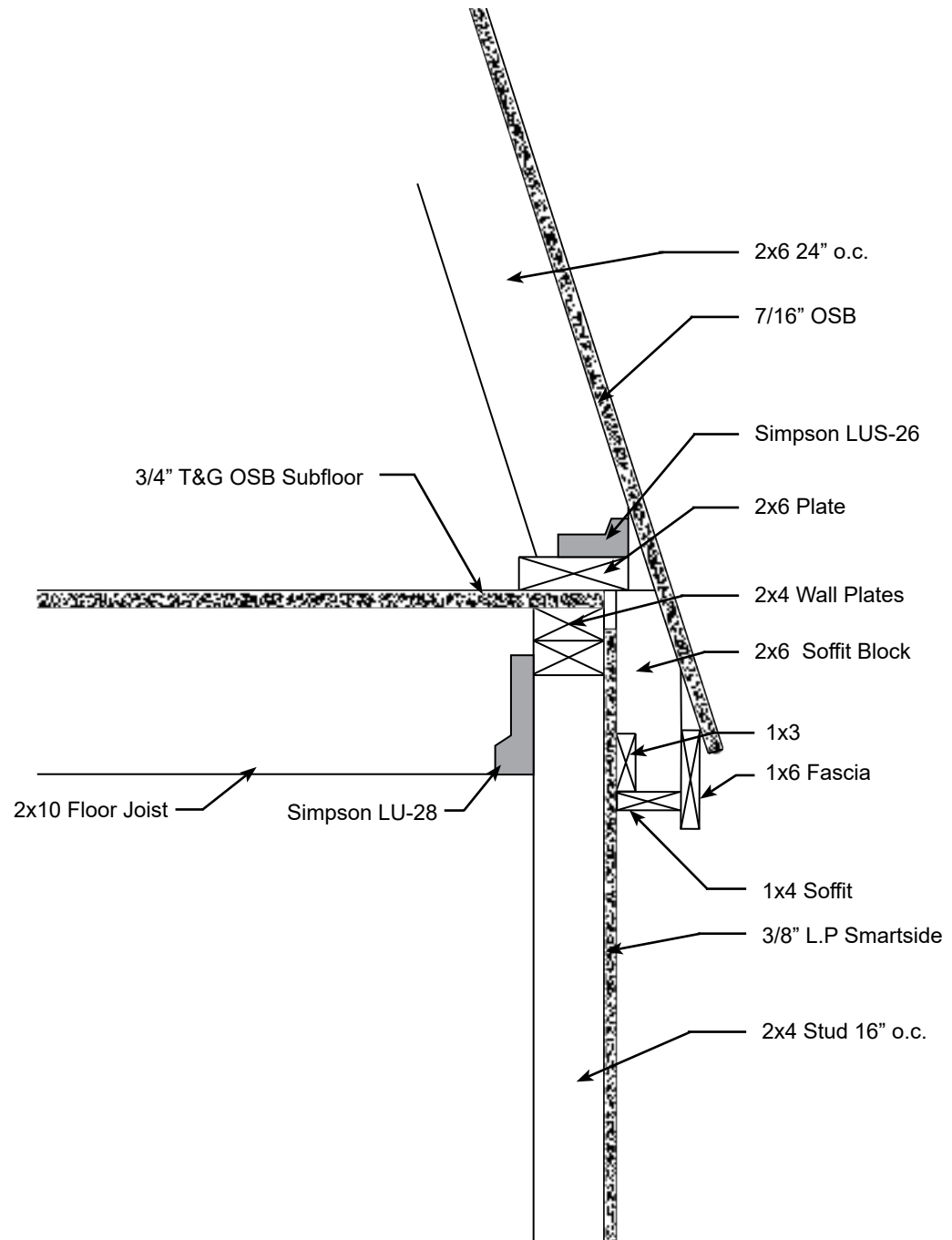

16ft. wide x ___ ft. long
2 Story Gambrel Building

Manufactured by:
RBS Holdings, LLC.
205 Arlington Drive
Greenville, PA 16125
phone: 800-245-1577
fax: 724-646-0772

Common Foundation Cross Sections

This document illustrates common foundation types which can be used for construction of the Ravenna model. Alteration may be necessary to conform to homeowners intended use and or permitting requirements.

Drawings not to scale.

Instructions:

Check appropriate foundation cross section and provide specifications as necessary.

Homeowner may also design and draw in space provided for custom foundation type.

Concrete Slab

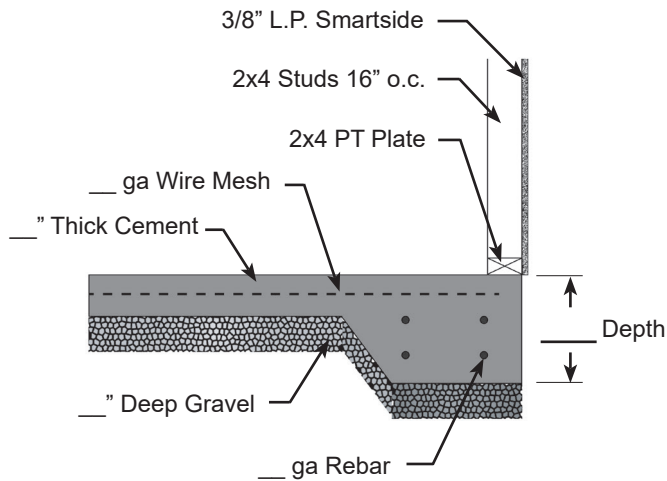

Crawl space or Basement

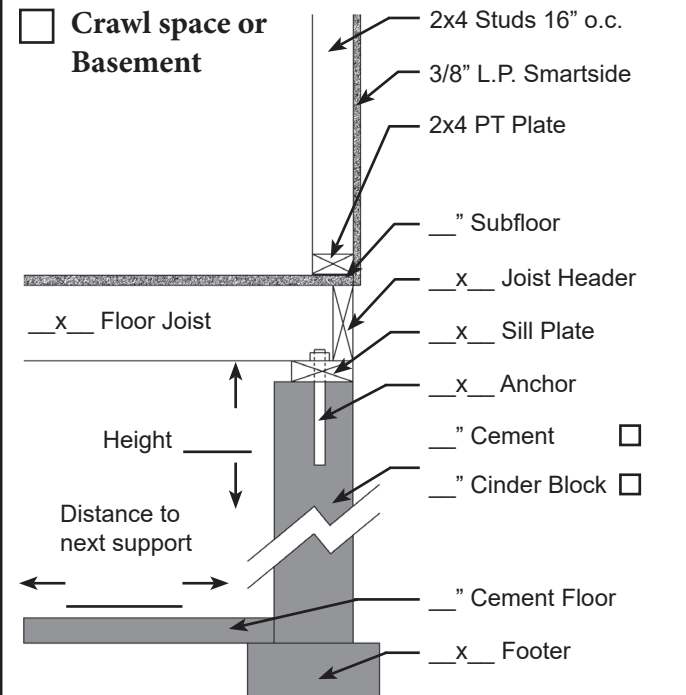

Homeowner Design

Post & Beam

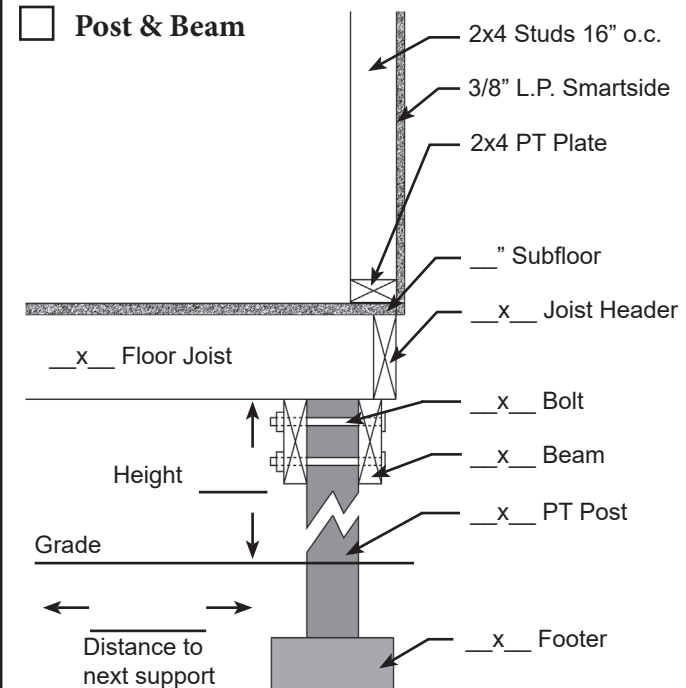

Site Plan for:

Manufactured by:
RBS Holdings, LLC.
205 Arlington Drive
Greenville, PA 16125
phone: 800-245-1577
fax: 724-646-0772

Instructions:

Draw property line, existing structures and proposed placement of building.

Homeowner may also be required to show trees and shrubs. Check with HOA or permit office for requirements.

