

Owner's Manual & Assembly Instructions

E01

Model No. ES109

697.68621

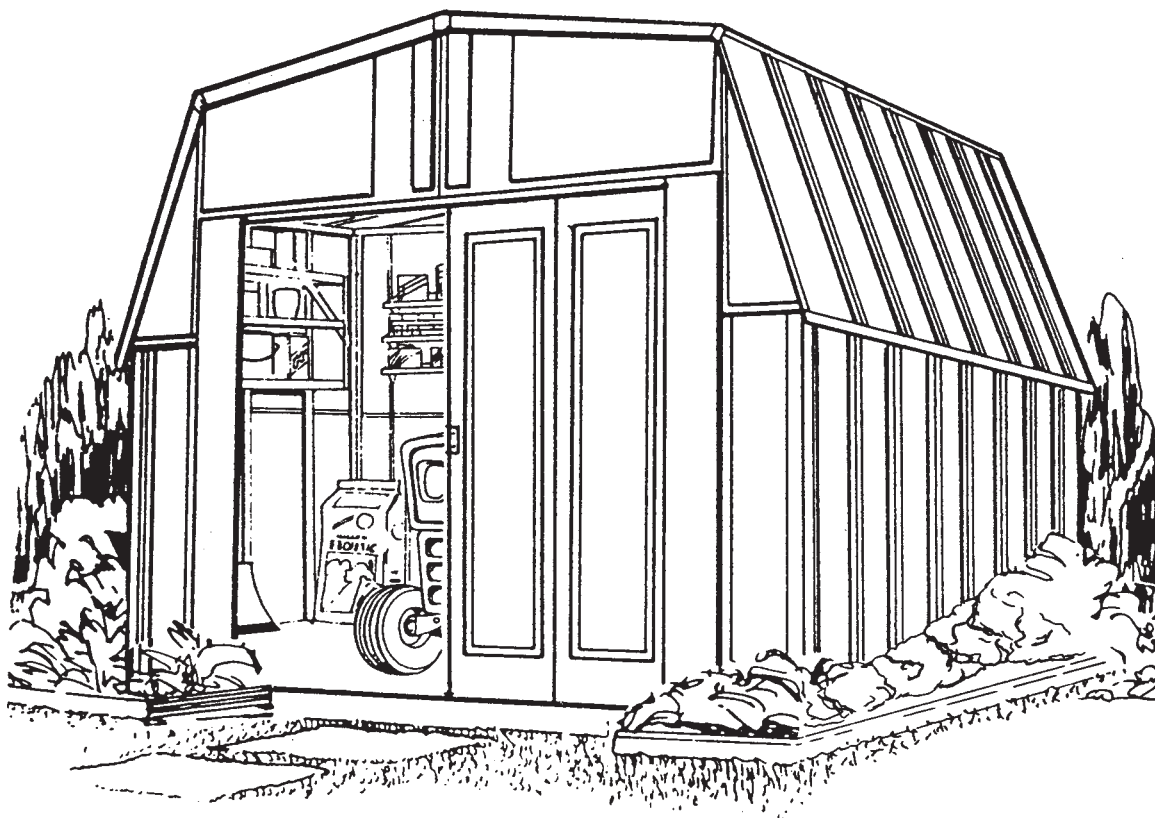

704711207

BUILDING DIMENSIONS * Size rounded off to the nearest foot



CAUTION: SOME PARTS HAVE SHARP EDGES. CARE MUST BE TAKEN WHEN HANDLING THE VARIOUS PIECES TO AVOID A MISHAP. FOR SAFETY SAKE, PLEASE READ SAFETY INFORMATION PROVIDED IN THIS MANUAL BEFORE BEGINNING CONSTRUCTION. WEAR GLOVES WHEN HANDLING METAL PARTS.

*Approx. Size	Foundation Size	Storage Area Sq. Ft. Cu. Ft.		Exterior Dimensions (Roof Edge to Roof Edge)			Interior Dimensions (Wall to Wall)			Door Opening	
				Width	Depth	Height	Width	Depth	Height	Width	Height
10' x 9'	121" x 105"	84	620	123 1/4"	107 1/2"	97 3/4"	118 1/4"	102 1/4"	96 1/2"	69"	68 1/4"
3,0m x 2,6m	307cm x 267cm	7,8m ²	17,6m ³	313cm	273cm	248cm	300cm	260cm	245cm	175cm	173cm

BEFORE YOU BEGIN...

A2

Owner's Manual

Before beginning construction, check local building codes regarding footings, location and other requirements. Study and understand this owner's manual.

Important information and helpful tips will make your construction easier and more enjoyable.

Assembly Instructions: Instructions are supplied in this manual and contain all appropriate information for your building model. Review all instructions before you begin, and during assembly, follow the step sequence carefully for correct results.

Foundation and Anchoring: Your storage building must be anchored to prevent wind damage. A foundation is also necessary as a base in order to construct a square and level building. Anchoring and foundation materials are not included with your building. We recommend the combined use of an **Arrow Floor Frame Kit** and an **Arrow Anchoring Kit** as an effective method of securing your building to the ground (Available by mail order or at your local dealer) or you may construct a foundation and anchoring system of your choice. Your assembly instructions provide information on a few methods commonly used to secure and level a storage building.

Parts and Parts List: Check to be sure that you have all the necessary parts for your building.

- All part numbers can be found on the parts. All of these numbers (before the -) must agree with the numbers on the parts list. The parts list is located on page 12.

- If you find that a part is missing, include the model number of your building and contact:

Arrow Group Industries, Inc. Customer Service Department
Route 50 East Breese, Illinois 62230
1-800-851-1085

- Separate contents of the carton by the part number while reviewing parts list. The first few steps show how to join related parts to make larger sub assemblies which will be used later.

- Familiarize yourself with the hardware and fasteners for easier use during construction. These are packaged within the carton. Note that extra fasteners have been supplied for your convenience.

PLAN AHEAD...

A3

Watch the Weather: Be sure the day you select to install your building is dry and calm. Do not attempt to assemble your building on a windy day. Be careful on wet or muddy ground.

Teamwork: Whenever possible, two or more people should work together to assemble your building. One person can position parts or panels while the other is able to handle the fasteners and the tools.

Tools and Materials: These are some basic tools and materials you will need for the construction of your building. Decide which method of anchoring and the type of foundation you wish to use in order to form a complete list of the materials you will need.

<p>Required</p> <ul style="list-style-type: none"> • Eye Goggles • No. 2 Phillips Screwdriver (With Hardened Magnetic Tip) <p>Note: A power screwdriver or variable speed drill with Phillips-tip attachment can speed assembly by as much as 40%.</p>	<p>Required</p> <ul style="list-style-type: none"> • Work Gloves • Step Ladder • Utility Knife / Scissors • Pliers • Carpenter's Level • Tape Measure 	<p>Optional Time-Savers</p> <ul style="list-style-type: none"> • Wrench / Nut Driver • Electric / Cordless Drill • Square • String (for squaring frame) 	<p>Foundation Preparation</p> <ul style="list-style-type: none"> • Hammer and Nails • Spade or Shovel • Hand Saw / Power Saw • Lumber and/or Concrete
--	---	---	---

Selecting and Preparing Your Site: Before assembly, you will want to decide on a location for your building. The best location is a level area with good drainage.

- Allow enough working space for ease of moving parts into position during assembly. Be sure there will be enough space at entrance for doors to open fully and enough space around the building to be able to fasten the panel screws from the outside.

- Before you begin the first steps in assembling your parts, a foundation should be constructed and an anchoring system should be ready to use.

SAFETY FIRST...

A4

Safety precautions are important to follow throughout the construction of your building.

•Care must be taken when handling various pieces of your building since some contain sharp edges. Please wear work gloves, eye protection and long sleeves when assembling or performing any maintenance on your building.

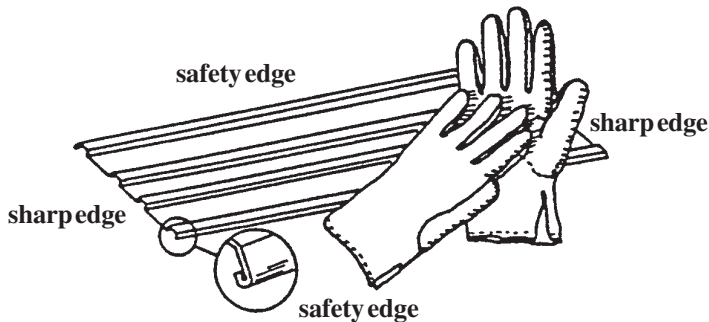

•Keep children and pets away from worksite to avoid distractions and any accidents which may occur.



•Never concentrate your total weight on the roof of the building. When using a step ladder make sure that it is fully open and on even ground before climbing on it.

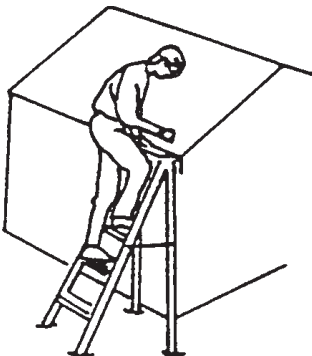

•Practice caution with the tools being used in the assembly of this building. Be familiar with the operation of all power tools.

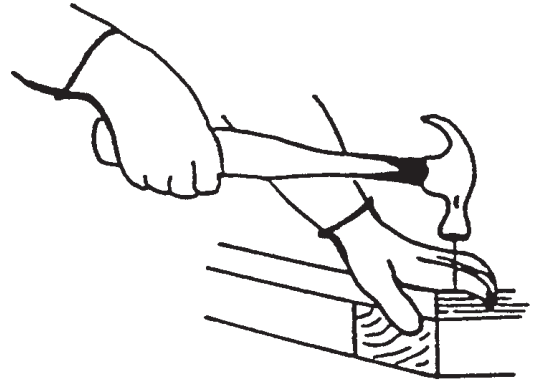

•Do not attempt to assemble the building if parts are missing because any building left partially assembled may be seriously damaged by light winds. Call 1-800-851-1085

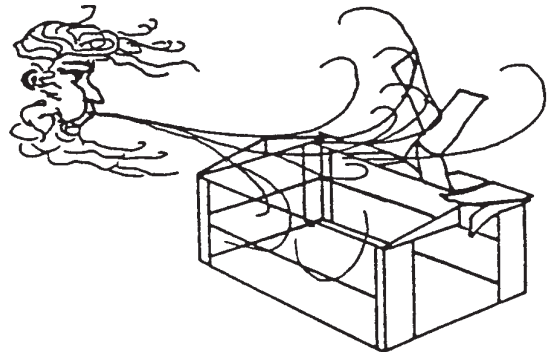

•Do not attempt to assemble the building on a windy day, because the large panels acting as a "sail", can be whipped about by the wind making construction difficult and unsafe.

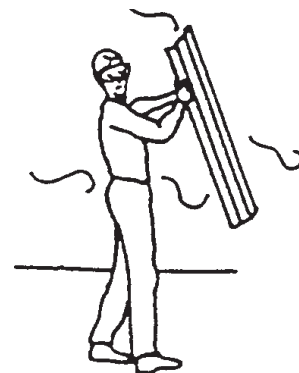

CARE & MAINTENANCE....

A5 Web

Finish: For long lasting finish, periodically clean and wax the exterior surface. Touch-up scratches as soon as you notice them on your unit. Immediately clean the area with a wire brush; wash it and apply touch-up paint per manufacturer's recommendation.

Roof: Keep roof clear of leaves and snow with long handled, soft-bristled broom. Heavy amounts of snow on roof can damage building making it unsafe to enter. In snow country, Roof Strengthening Kits are available for most Arrow Buildings for added protection against heavy snow accumulation.

Doors: Always keep the door tracks clear of dirt and other debris that prevent them from sliding easily. Lubricate door track annually with furniture polish or silicone spray. Keep doors closed and locked to prevent wind damage.

Fasteners: Use all washers supplied to protect against weather infiltration and to protect the metal from being scratched by screws. Regularly check your building for loose screws, bolts, nuts, etc. and retighten them as necessary.

Moisture: A plastic sheet (vapor barrier) placed under the entire floor area with good ventilation will reduce condensation.

Other Tips....

- Wash off inked part numbers on coated panels with soap and water.
- Silicone caulking may be used for watertight seals throughout the building.

Do not store swimming pool chemicals in your building. Combustibles and corrosives must be stored in air tight approved containers.

Keep this Owner's Manual and Assembly Instructions for future reference.

ACCESSORIES...

A6 WEB

ROOF STRENGTHENING (heavy snow load) KITS

Extra roof beams and gable braces designed for added protection against heavy snow accumulation. Increases the strength of your roof by 50%.

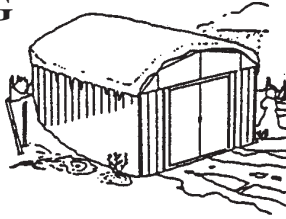

ANCHOR KITS

Model No. AK4

Anchor Kit contains heavy-duty steel augers, 60' (18m) of steel cable and 4 cable clamps. No digging or concrete pouring, just insert cable under roof, over roof beams, into augers and twist augers into the ground. For buildings larger than 10'x9', use 2 kits.

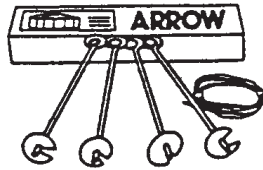

Model No. AK100

New concrete anchor system permits anchoring any size Arrow building directly to a concrete slab. Each kit contains heavy-duty, hot-dipped galvanized steel corner gussets and perimeter clips which fit over the floor frame and lag bolt into a concrete slab. Full assembly instructions and a 1/4" masonry drill bit are included.

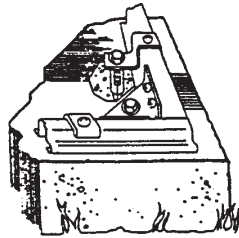

Model No. AK600

Earth Anchor Kit anchors any size Arrow building to the ground. Each kit contains heavy duty, hot-dipped galvanized steel corner gussets and 4 earth anchors.

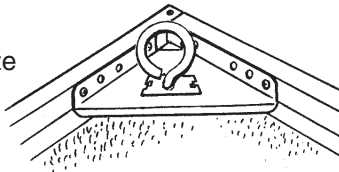

TOOL HANGING RACK

Model No. TH100

The perfect tool organizer. Twin 25 1/2" (65cm) steel channels plus five heavy-duty snap-in hangers and a small tool holder for screwdrivers, pliers, etc. Holders slide along channel for fully adjustable spacing. Great for garage, basement, or the back of any door. Fits all Arrow storage buildings.

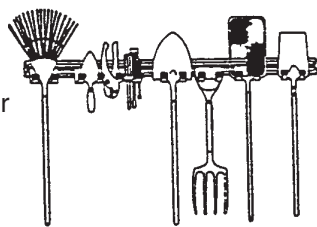

FLOOR FRAME KITS



MODELS FB47410, FB5465, FB106-A
FB109-A and FB1014-A

A simple new floor frame system made of heavy-duty, hot-dipped galvanized steel. Use as foundation for plywood, sand or stone.

ATTIC KIT / WORKBENCH KIT

Heavy-duty galvanized steel bars that fit all 10' wide Arrow buildings. They install quickly and easily to help organize space and create more useable space as an attic or workbench. Will hold up to 250 lbs. (113kg) evenly distributed.

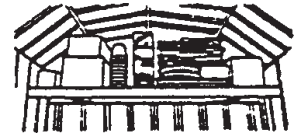

Model No.	Fits	Shipping Weight
AT101	10' Long, 250 lb. (113kg) load+ Fits all Arrow 10' wide buildings.	16 lbs. (7kg)

Must be drilled for use as workbench in Estator.
+ Even weight distribution.

SHELF UNITS

Heavy-duty, galvanized steel shelf units help organize storage space. They easily mount on the wall or sit on the floor. Fits all Arrow buildings.*

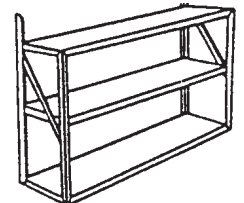
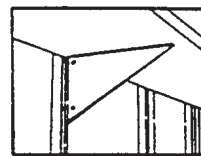
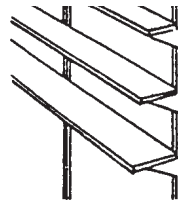

Model No. SS404

- Makes 8" to 12" (20-30cm) wide shelves in any length.
- Brackets, braces, hardware included. Lumber is not included.

Model No. SS900-A

- Grey color
- 3 shelves
- Holds up to 85 lbs. (38kg) (even weight distribution)

* Some drilling required to fit buildings without mid-wall bracing.

THIS
PAGE
WAS
LEFT
BLANK
INTENTIONALLY

THIS
PAGE
WAS
LEFT
BLANK
INTENTIONALLY

Foundation

K09

The Foundation For Your Building

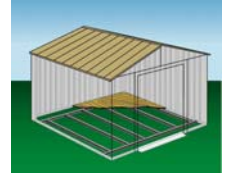

OPTION 1: ARROW FLOOR FRAME KIT: (Order No. FB109-A or 68385-A)

Arrow has the best base for your building in this simple kit. It keeps stored items above the ground. This kit should be used with one of the following:

A. To support a plywood deck **B.** To be filled with sand. We recommend the combined use of

1. an **ARROW FLOOR FRAME KIT** and **2.** an **ARROW ANCHORING KIT** as an effective method of securing the building to the ground.

Allow 1 - 2 hours for construction.

OPTION 2: Wood Platform

If you decide to build your own foundation, be sure to select the appropriate materials.

These are the recommended materials for your foundation:

- 2 x 4's (5cm x 10cm) Pressure Treated Lumber
- 5/8" (1,5cm) 4 x 8 (122cm x 244cm) Plywood-exterior grade
- 10 & 4 penny Galvanized Nails
- Concrete Blocks (optional)

The platform should be level and flat (free of bumps, ridges etc.) to provide good support for the building. The necessary materials may be obtained from your local lumber yard.

To construct the foundation follow instructions and diagram.

Construct frame (using 10 penny galvanized nails)
Measure 16"/24" (40,6cm/61cm) sections to construct inside frame (see diagram)

Secure plywood to frame (using 4 penny galvanized nails)

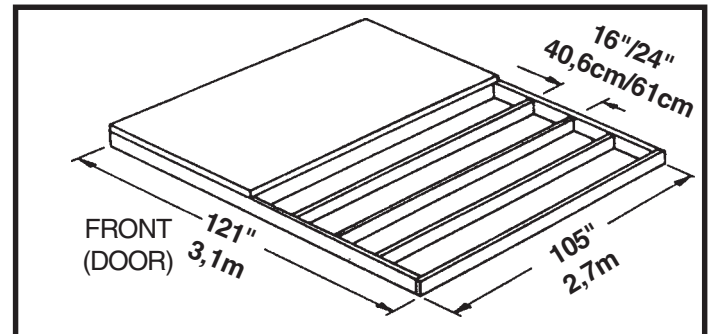

Allow 6 - 7 hours for construction.

Note: Platform/Slab will extend 9/16" (1,4cm) beyond floor frame on all four sides. Seal this 9/16" of wood with a roofing cement (not included), or bevel this 9/16" of concrete when pouring, for good water drainage.

OPTION 3: Concrete Slab

The slab should be at least 3" to 4" (8-10cm) thick. It must be level and flat to provide good support for the frame.

The following are the recommended materials for your foundation.

- 1 x 4's (2,5cm x 10cm) (will be removed once the concrete cures)
- Concrete
- Sheet of 6 mil plastic
- We recommend for a proper strength concrete to use a mix of:
1 part cement ● 3 parts pea sized gravel ● 2 1/2 parts clean sand

Prepare the Site/Construct a Foundation

1. Dig a square, 6" (15cm) deep into the ground (remove grass).
2. Fill up to 4" (10cm) in the square with gravel and tamp firm.
3. Cover gravel with a sheet of 6 mil plastic.
4. Construct a wood frame using four planks of 1x4 (2,5cm x 10cm) lumber.
5. Pour in concrete to fill in the hole and the frame giving a total of 4" (8-10cm) thick concrete. Be sure surface is level.

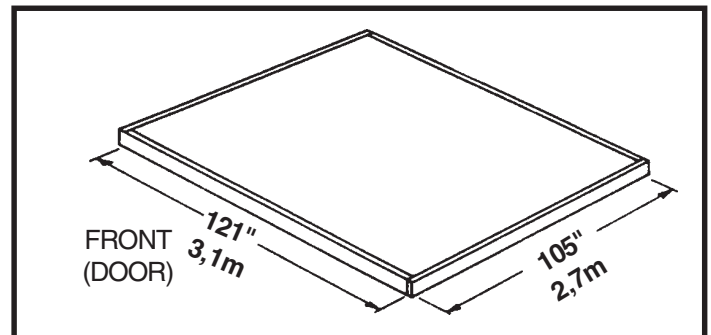

Note: Finished Slab dimensions, with lumber removed.

Allow 3 - 5 hours for construction and a week for concrete curing time.

Anchoring

A10

Anchoring Down The Building

It is important that the entire floor frame be anchored after the building is erected.

Below are recommended ways of anchoring.

Arrow Anchoring Kit: (Model No. AK4 or 60298)

Recommended for use with **any** suggested **base**.

Contains: 4 Anchors with Cable, Clamps and installation instruction.

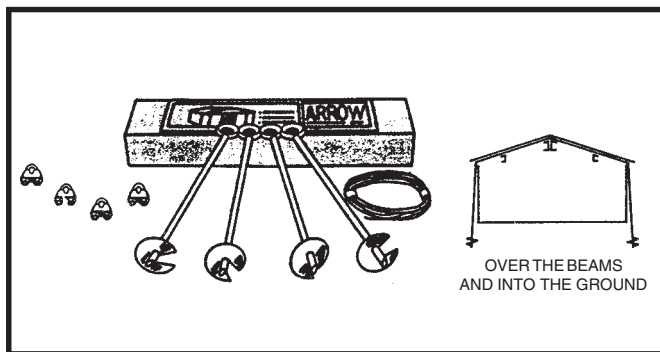

Anchoring into Wood/Post:

Use 1/4" Wood Screws. There are 1/4" (0,63cm) dia. holes provided in the frames for proper anchoring.

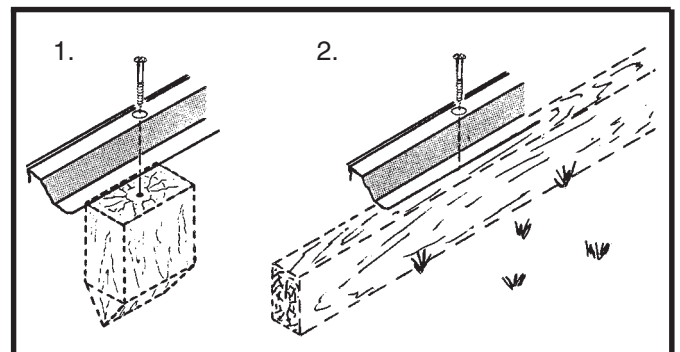

Arrow Anchoring Kit: (Model No. AK100 or 68383)

Recommended for use with the **concrete** foundation.

Contains: Corner gussets, perimeter clips, hardware, 1/4" masonry drill bit and installation instruction.

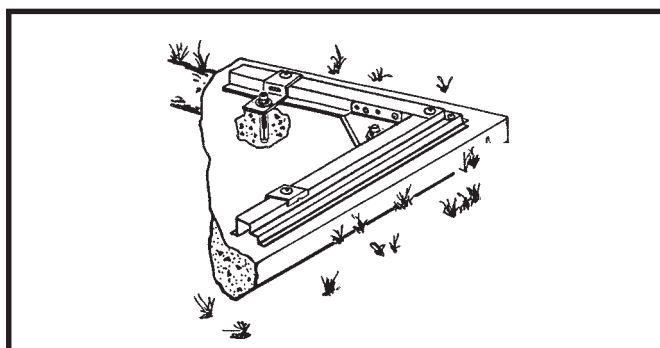

Anchoring into Concrete:

1. For poured concrete slab or footing or patio blocks: Use 1/4" x 2" Lag Screws.
2. For Anchor Post of Concrete poured after building is erected: Use 1/4" x 6" Lag Screws.

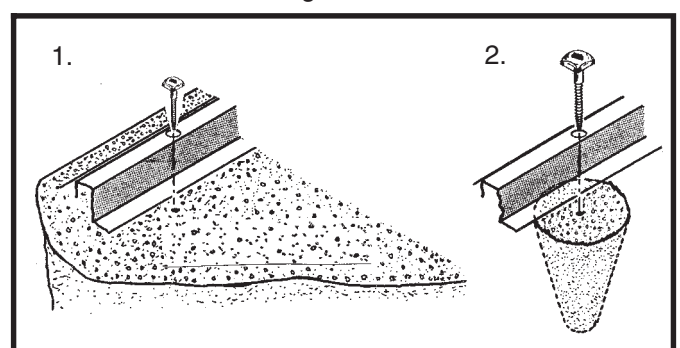

Hardware

E11

Remove from bag of screws
and save for the last step



65103
#8-32 Hex Nut (228)



65900A
#10Bx1/2" Black Screw (20)
(Packed with Screws)



65923
#8-32x3/8" Bolt (224)



65004
#8Ax5/16" Screw (308)



65914
#6Ax7/8" Screw (6)
(Packed with Screws)



65958
#8-32x7/8" Bolt (2)
(Packed with Screws)



66013
#8-32x1/4" Bolt (5)



65109
#8-32 Acorn Nut (6)
(Packed with Screws)

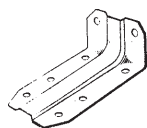

6228
Track Support (4)

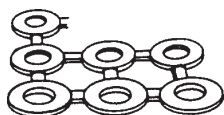

66646
Washer (560)

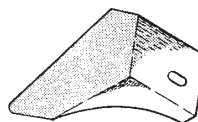

66444
Roof Trim Cap
(2 right & 2 left)

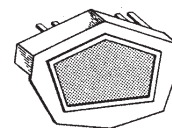

66446
Peak Cap (2)
(Arrow Logo)



66769
Door Slide (10)

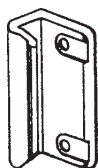

66045
Handle (2)

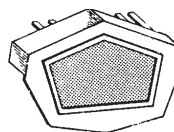

66447
Facia Cap (4)

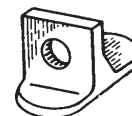

66382
Lower Door Guide (8)



66029
Door Plug (4)
(Packed with Screws)

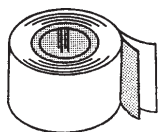

67293
Weather Stripping (1)

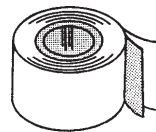

67545
Weather Stripping (1)



66098
Plastic Spacer (8)
(Packed with Screws)

Parts List

E12

Parts In Carton One

Assembly Key No.	Part Number	Part Description	Quantity In Carton	Check List
1	0546	Large Right Gable	2	
2	0547	Large Left Gable	2	
3	9024	Front Rear Wall Panel	4	
4	9025	Rear Wall Panel	2	
5	9026	Rear Wall Panel	2	
6	9028	Right Outer Gable	2	
7	9029	Left Outer Gable	2	
8	10480	Right Door	2	
9	10481	Left Door	2	
10	10504	Horizontal Door Brace	6	
11	9033	Door Jamb	2	
12	9021	Left Roof Panel	2	
13	9020	Right Roof Panel	2	
14	9022	Main Roof Panel	4	
15	9023	Corner Panel	4	
16	9027	Main Wall Panel	4	

Parts In Carton Two

Assembly Key No.	Part Number	Part Description	Quantity In Carton	Check List
18	0246	Roof Beam Bracket	4	
19	0248	Gable Brace	2	
20	10507	Secondary Door Track	2	
21	0545	Mid Roof Beam Bracket	4	
22	5223	Ridge Cap	1	
23	5219	Side Roof Trim	2	
24	8947	Side Floor Frame	2	
25	9034	Right Roof Trim	2	
26	9035	Left Roof Trim	2	
27	9037	Door Track	1	
28	9038	Horizontal Attic Channel	4	
29	9039	Horizontal Attic Channel	1	
30	9042	Angle Brace	4	
31	9043	Rear Wall Angle	1	
32	9044	Floor Angle	1	
33	9046	Front Floor Frame	1	
34	9047	Rear Floor Frame	1	
35	9048	Vertical Attic Channel	1	
36	9036	Hip Trim	2	
37	9143	Outer Roof Beam	4	
38	9041	Side Eave Channel	2	
39	9045	Rear Wall Channel	1	
40	9144	Main Roof Beam	2	
41	9040	Vertical Attic Channel	2	
42	9154	Roof Beam Brace	5	

Assembly by Key No.

E13

KEY NUMBERS 28, 29, 35 & 41 ARE SHOWN ON STEP 16

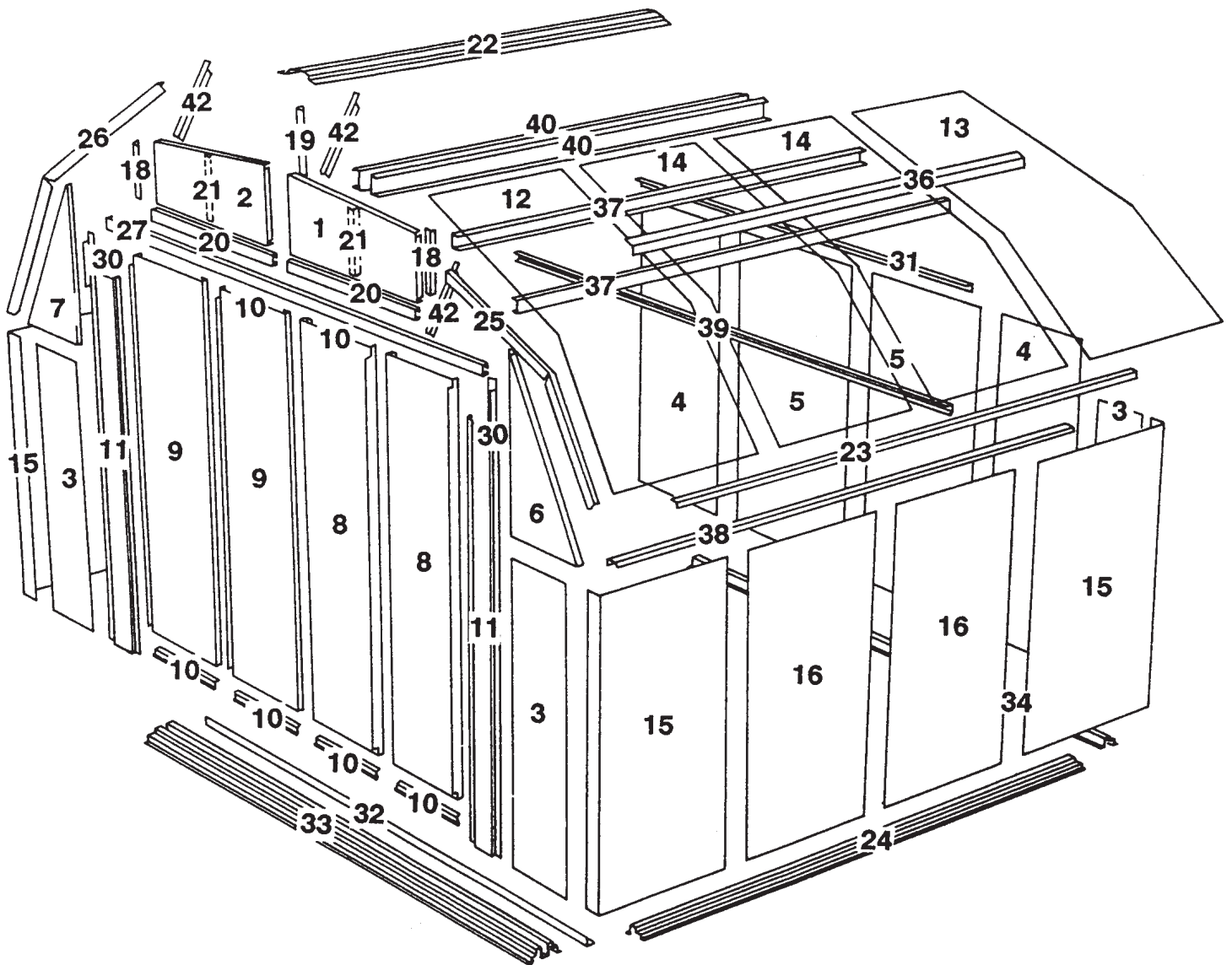

Step 1

E14

● Parts Needed For ● Large Gable Assembly

- 0545 Mid Roof Beam Bracket (4)
- 0546 Large Right Gable (2)
- 0547 Large Left Gable (2)

The gables go on top of the front and rear walls to support the roof beams.

NOTE

The gables are packed nested together and might be mistaken as one piece. Carefully separate them before continuing.

- 1** Attach the four **mid roof beam brackets** to **large right and left gables** using four bolts, washers and nuts.

NOTE

Mounting leg of bracket must face toward center of gable.

- 2** Set these pieces aside for later assembly.

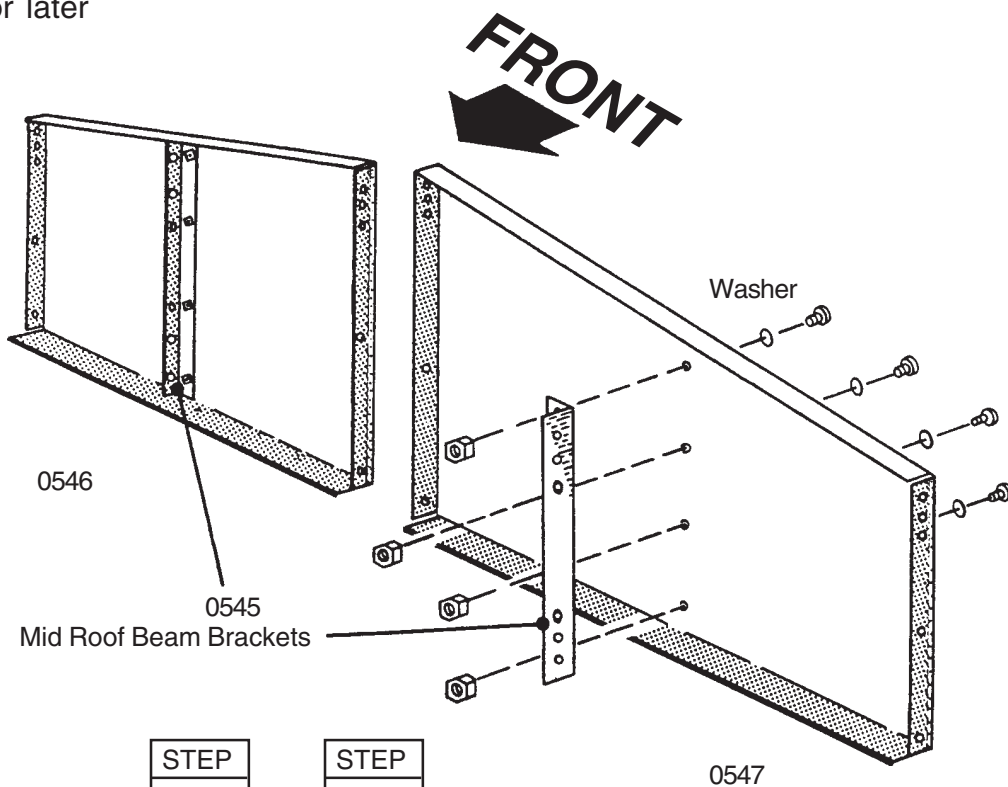

Step 2

E15

● Parts Needed For ● Floor Frame Assembly

- 9044 Floor Angle (1)
- 9046 Front Floor Frame (1)
- 9047 Rear Floor Frame (1)
- 8947 Side Floor Frame (2)

1 Position **floor angle** inside channel of **front floor frame** in the direction shown and fasten with five 1/4" bolts from the bottom with nuts on top. Place the **floor frame** pieces on the foundation. Assemble the four corners of the floor frame using two screws at each corner as shown. At the front corners fasten 3/8" bolts through from the bottom with nuts on top.

2 Measure the floor frame diagonally. When the diagonal measurements are equal, the floor frame is square.

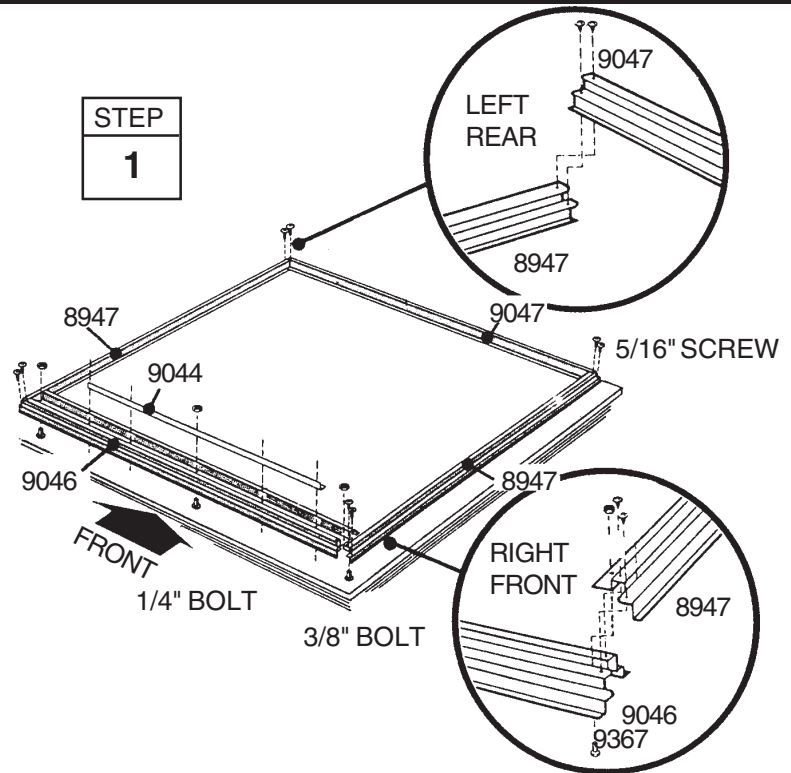

NOTE

If using a wood platform or concrete slab do not fasten the floor frames to your base at this time. You will anchor the building after it is erected.

NOTE

If you have purchased a Floor Frame Kit you need to install it at this time.



END VIEW

When Diagonal Measurements are Equal the Floor Frame is Square.

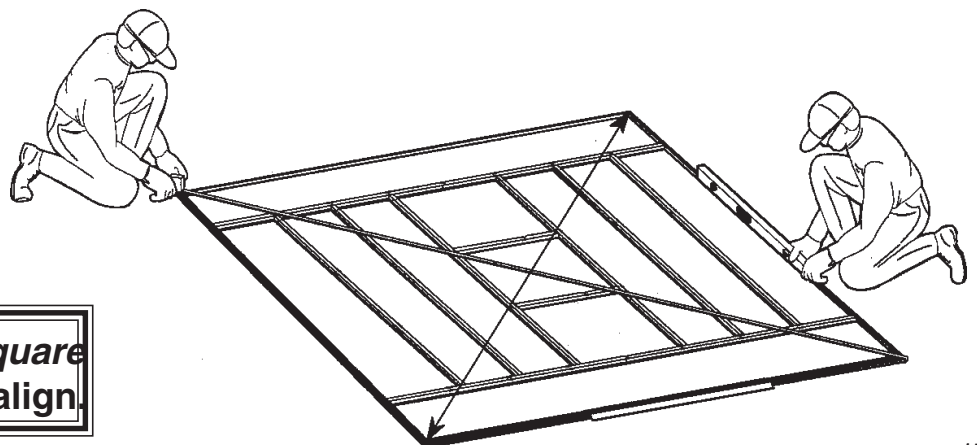
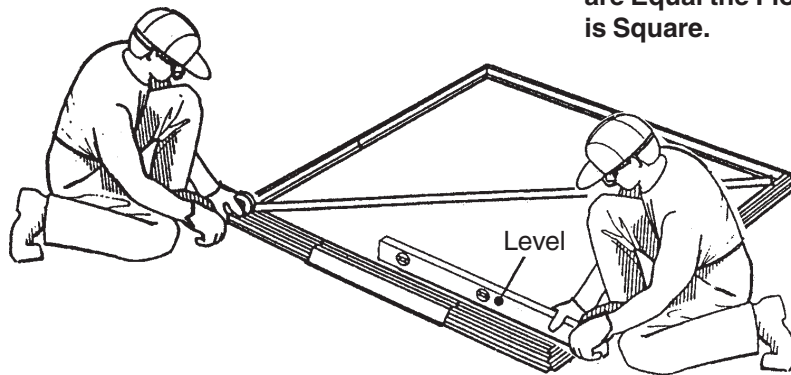

The floor frame *must be square and level* or holes will not align.

Step 3

E16

● Parts Needed For ● Corners

- 9024 Front/Rear Wall Panel (4)
- 9023 Corner Panel (4)

NOTE

The remainder of the building assembly requires many hours and more than one person. Do not continue beyond this point if you do not have enough time to complete the assembly today. A partially assembled building can be severely damaged by light winds.

Each screw and bolt in the wall requires a washer.

1 Position a **corner panel** at the corner of the floor frame as shown. The widest part of each corner panel must be placed along the side of the building for all four corners. Fasten the corner panel to the floor frame with four screws.

STEP
1

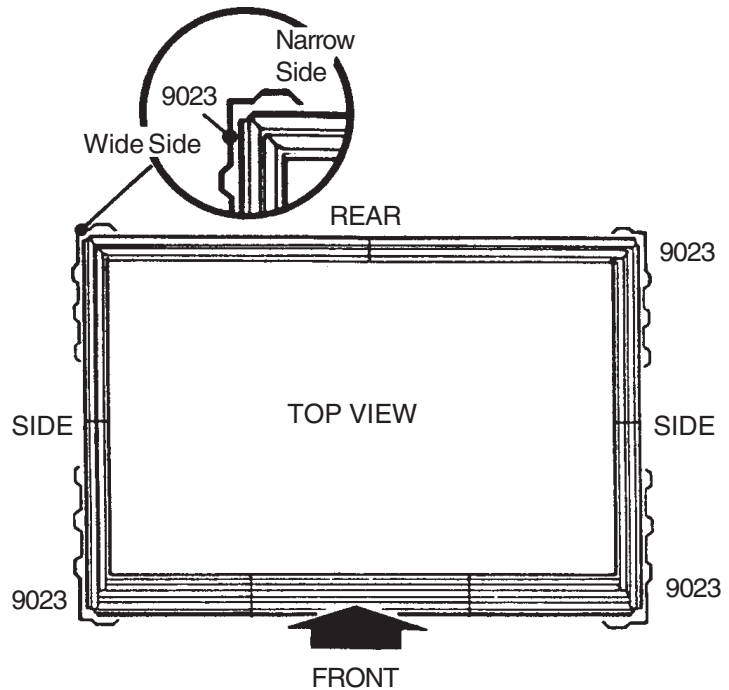

Support the corner panel with a step ladder until a wall panel is attached.

2 Attach the **front/rear wall panels** to the front corner panels, as shown.

3 Attach the **front/rear wall panels** to the rear corner panels, as shown. Fill in two holes in panel with bolts and nuts where shown.

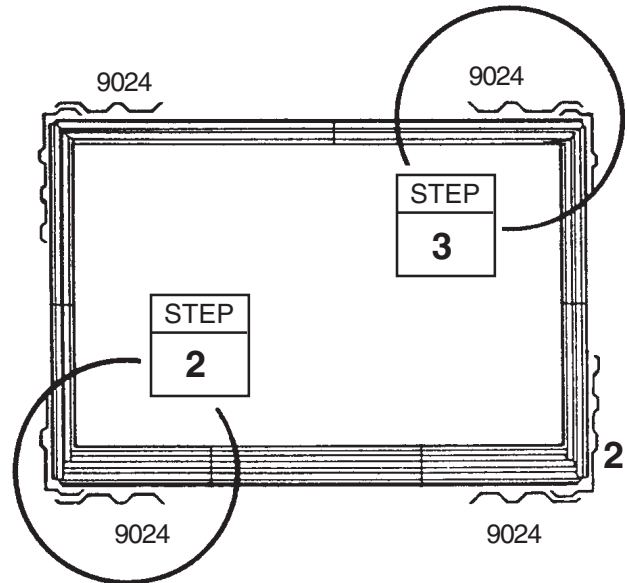

NOTE

Be careful to install the correct panel in each position as shown

4 Double-check the part numbers of the wall panels, before proceeding.

The floor frame *must be square and level* or holes will not align.

STEP
4

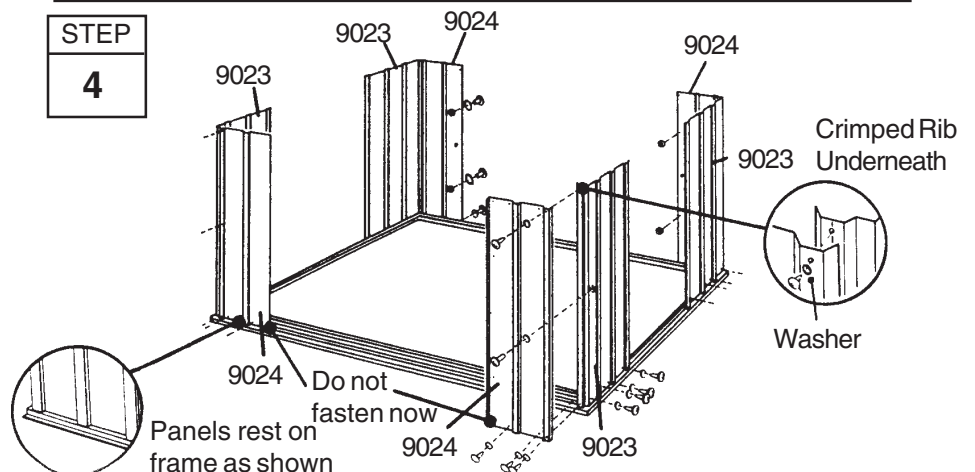

Step 4

E17

● Parts Needed For ● Frames

- 9041 Side Eave Channel (2)
- 9045 Rear Wall Channel (1)

The main frame pieces give rigidity to the side walls and provide a surface for attaching the gables which support the roof.

1 Temporarily fasten the **rear wall channel** across the top of the rear wall using bolts and nuts.

2 Fasten the **side eave channels** across the top of the side panels using bolts from the inside and nuts outside.

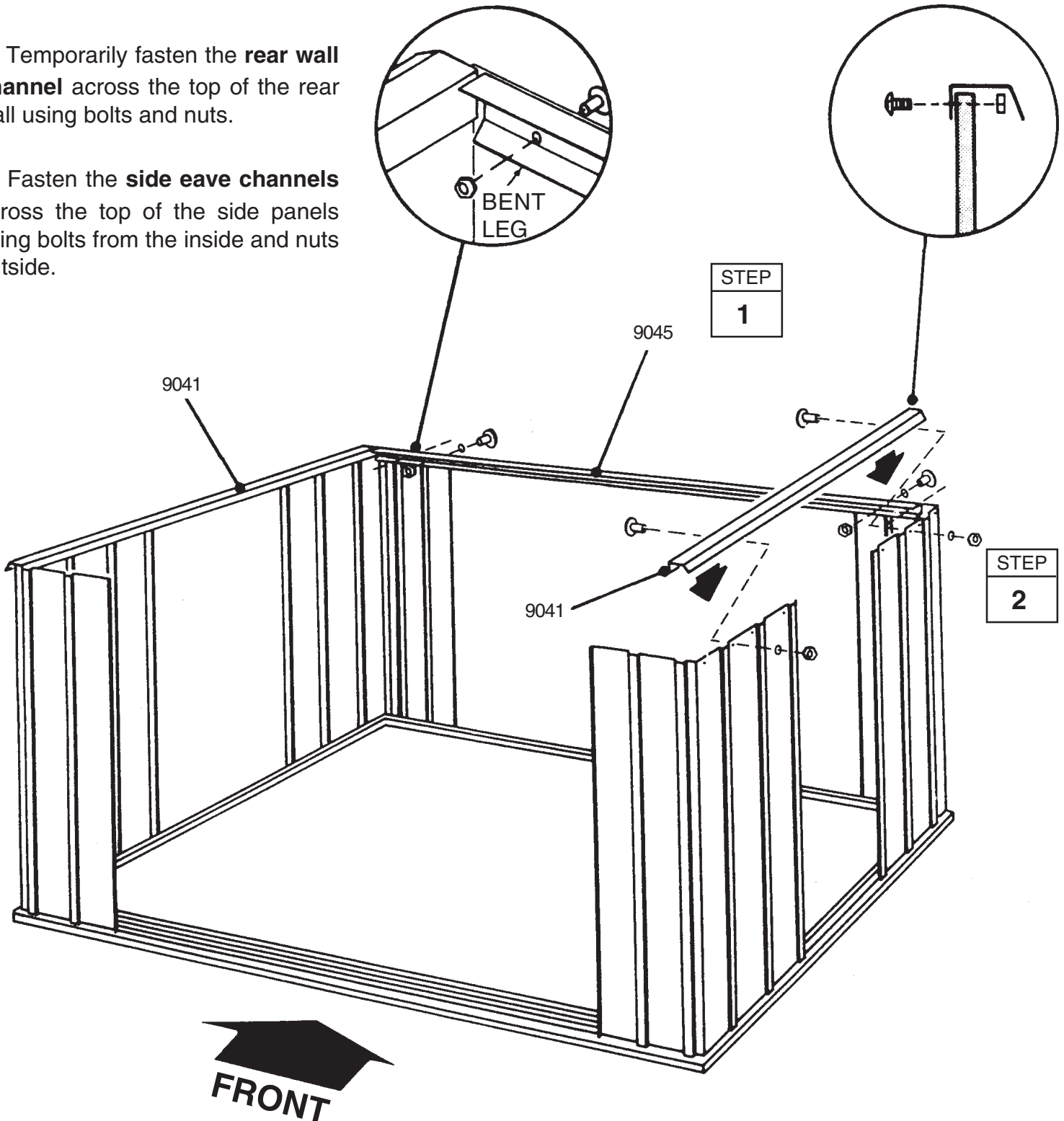

Step 5

E18

● Parts Needed For ● Door Jamb/Track

- 9033 Door Jamb (2)
- 9037 Door Track (1)

The door jambs reinforce the door opening and provide an attractive trim. Follow these steps for both door jambs. The door track supports the sliding doors and reinforces the front wall.

1 Fasten a **door jamb** to the front wall panel with two screws into floor frame.

2 Fasten the lower center of the door jamb to the front panel with a bolt inside, and a hex nut with an acorn nut outside, where shown.

Repeat steps 1 and 2 for the *opposite* door jamb.

3 Fasten the **door track** (holes on top) across the top rear of door jambs using one screw in each jamb. See the figure.

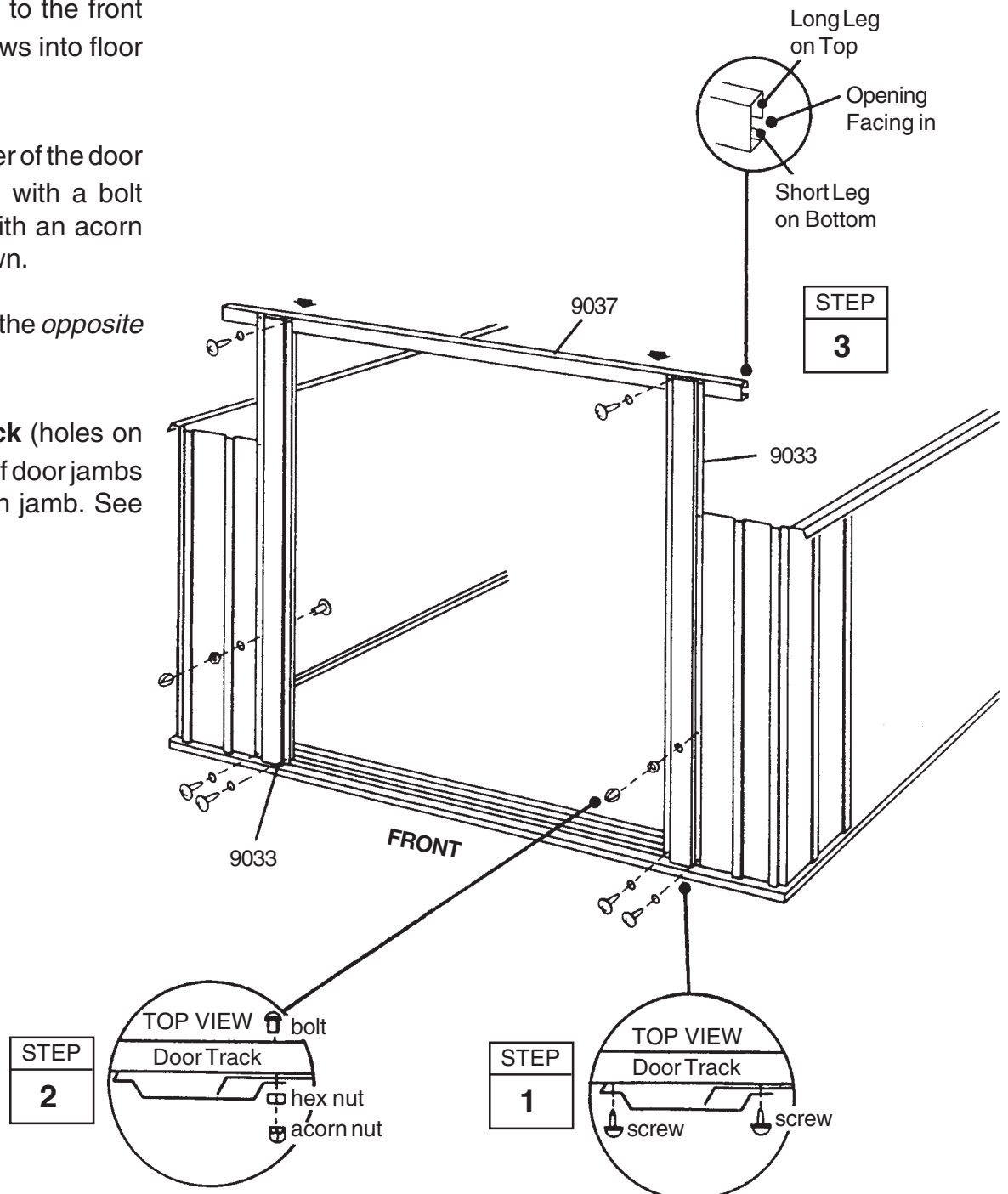

Step 6

E19

● Parts Needed For ● Outer Gable Assembly

- 9042 Angle Brace (4)
- 9028 Right Outer Gable (2)
- 9029 Left Outer Gable (2)
- 9026 Rear Wall Panel (2)
- 9043 Rear Wall Angle (1)

The gables go on top of the front and rear walls to support the roof.

NOTE

The gables are packed nested together and might be mistaken as one piece. Carefully separate them before continuing.

1 Attach the **angle braces** to the **right and left outer gables** using screws. Attach a **track support** to one left and one right gable using a bolt and nut. See the figure.

2 Fasten the two gables, with track supports, to the front of building, bottom leg behind wall panel, using screws, bolts, nuts and acorn nuts as shown. Angle brace fits behind door jamb.

3 Fasten remaining gables to rear of building. Gable legs fit between rear wall channel and wall panels. Remove and reinsert the bolts and nuts in corners.

4 Install **rear wall panels** to channel and frame (centered on rear wall) using bolts and screws. Fasten overlap with bolts and nuts, and screws at top and bottom.

5 Fasten **rear wall angle** across the inside top of rear panels using screws.

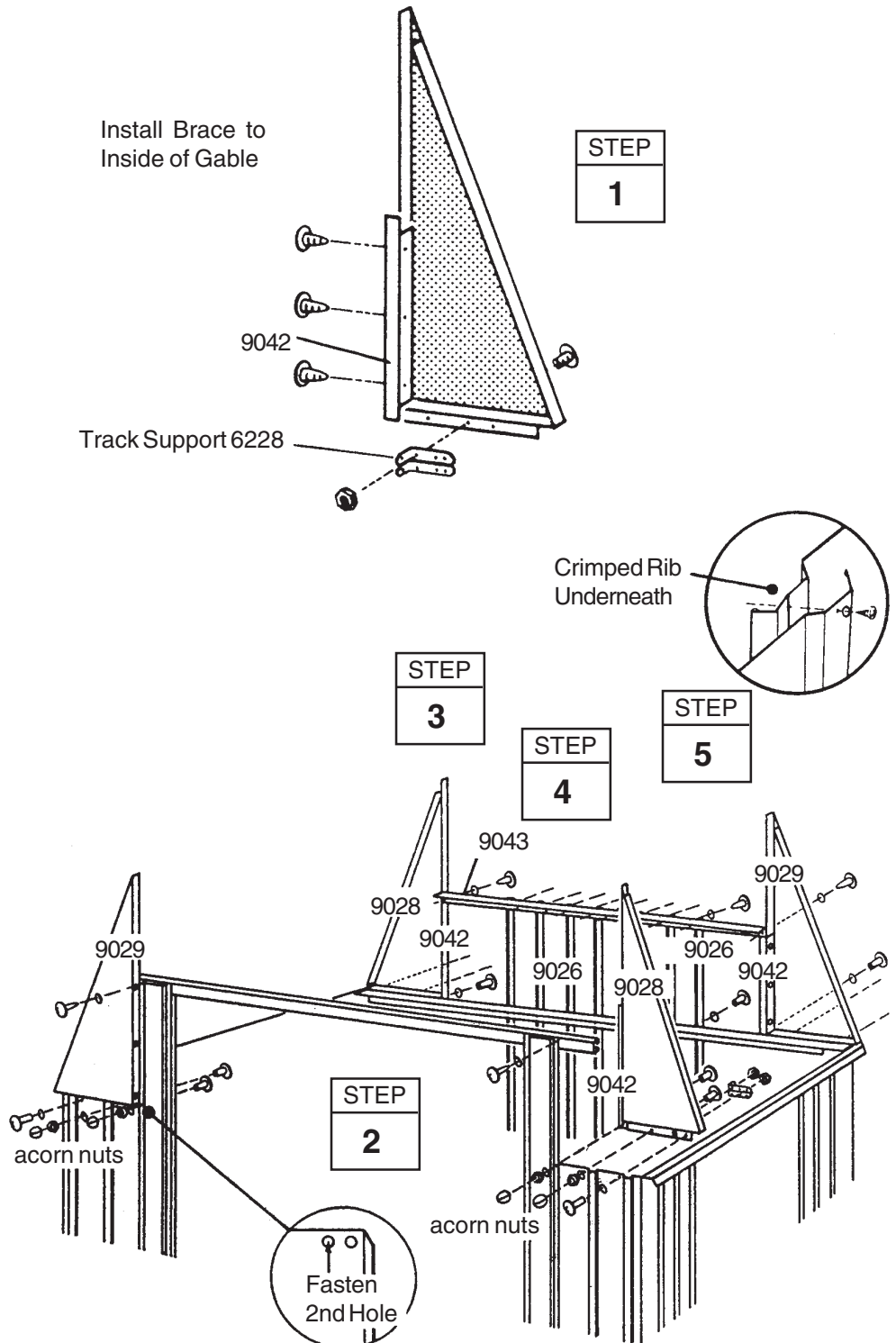

Step 7

E20

● Parts Needed For ● Wall Assembly

- 9027 Main Wall Panel (4)
- 9025 Rear Wall Panel (2)

The wall panels come in two lengths. Each wall panel has a crimped rib on one side. The crimped rib should go under the rib of the panel that follows it.

1 Locate all of the **main wall panels** and set each one alongside the building. Fasten the wall panels at the top with bolts and nuts and the bottom with screws.

2 Fasten panel rib where it overlaps the adjacent panel using a bolt and nut, with screws where shown.

3 Install **rear wall panels** to angle, channel and frame using bolts and screws. Fasten overlaps with bolts, except outer ribs, use a 7/8" bolt, spacer and nut. Use 7/8" screw and spacer at bottom of rib into frame.

4 Fasten rear wall angle at the outer ribs using 7/8" screws and spacers.

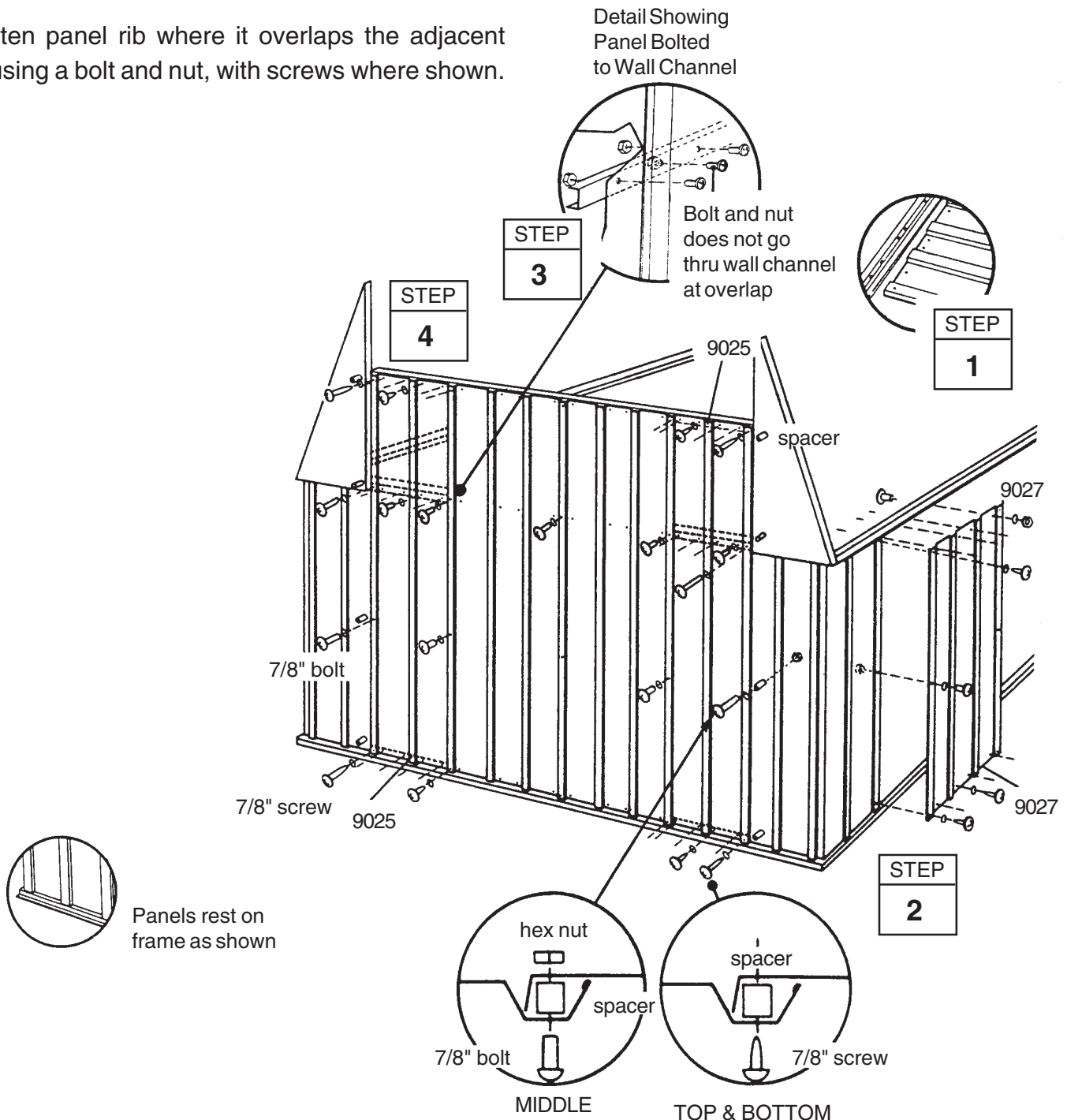

Step 8

E21

● Parts Needed For ● Gables/Brackets/Braces

- Gable Assembly (4)
- 0246 Roof Beam Bracket (4)
- 0248 Gable Brace (2)

1 Lift and fasten a large right gable to the door track using screws.

Hint: On the front gable, leave out 2 screws closest to center of gable.

2 Join large gable to the outer gable together with a **roof beam bracket** using a bolt in the 4th hole from the bottom. Leg of bracket must face center of building.

Repeat Steps 1 and 2 for the large left gable.

3 Join the left and right gables together with a **gable brace** using bolt in the 2nd hole from the bottom.

4 Fasten the **track supports** to the front gable assembly, as shown.

Repeat Steps 1 through 3 for the rear of building. Fasten gable brace using bolts in the bottom 2 holes.

5 Apply the **weather stripping** along the mating edge of the large left and right gables and the large and outer gables, as shown. Cut the weather stripping to length.

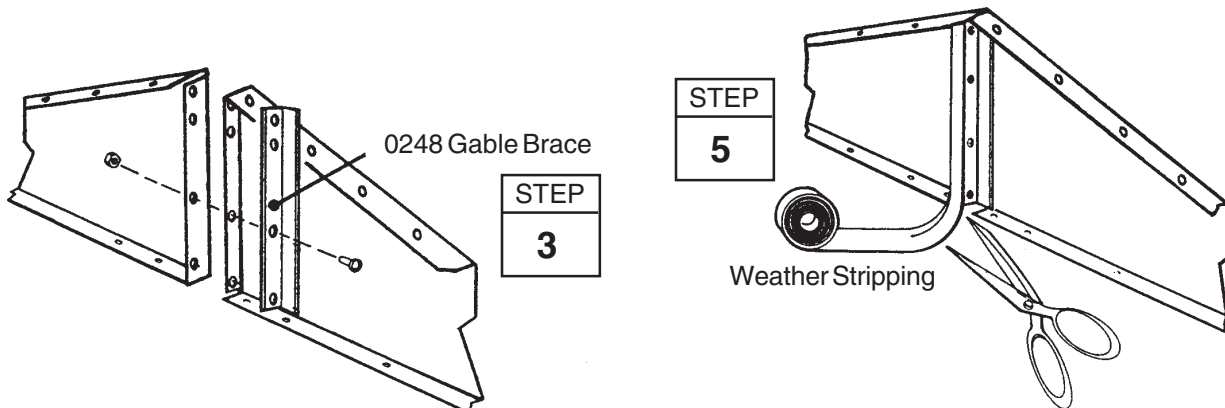
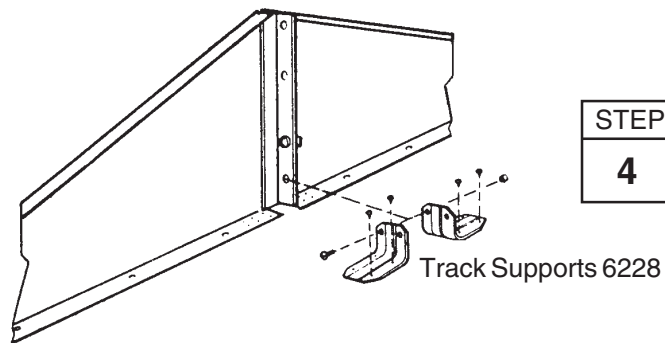
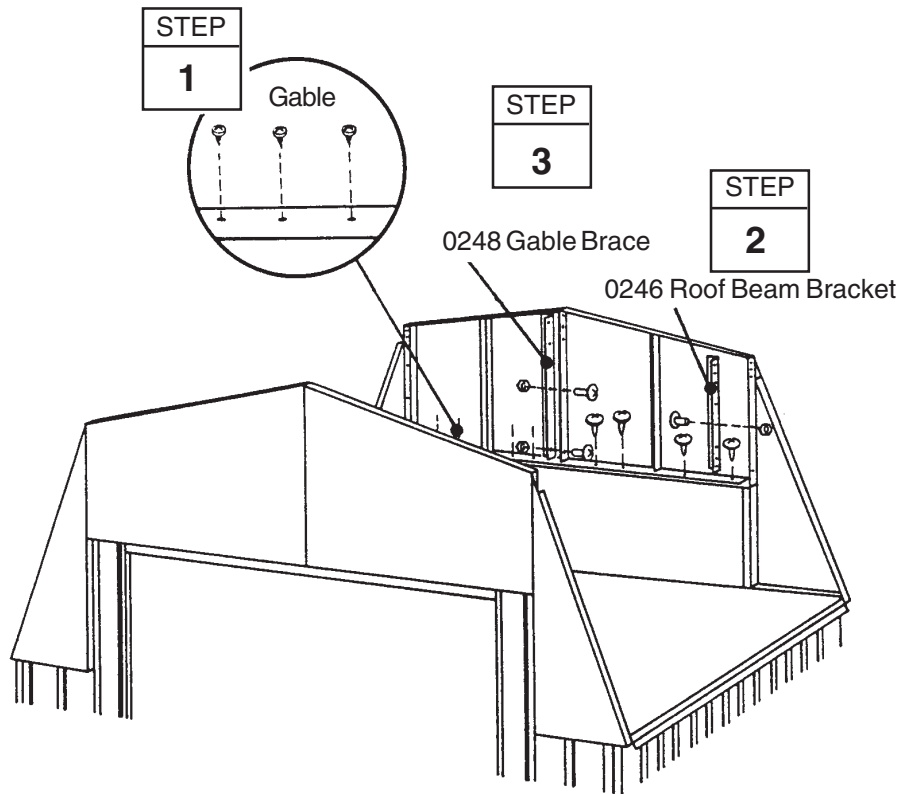

Step 9

E22

● Parts Needed For ● Roof Beam/Brace Assembly

- 9144 Main Roof Beam (2)
- 9143 Outer Roof Beam (4)
- 9154 Roof Beam Brace (5)

1 Attach **main roof beams**, back to back, at the 4 middle holes with bolts and nuts. Spread the two halves of the main roof beams and fasten to the gable brace of the front gable as shown using bolts. The holes along the length of beams must be on *top* surface.

2 Fasten the other end of the main roof beams to the gable brace of the rear gable.

3 Install **outer roof beams** where large and outer gables are joined with legs facing inward, using bolts.

4 Fasten **outer roof beams** to mid roof beam brackets, legs facing outward, with bolts and nuts.

5 Attach a **roof beam brace** to side of gable leg, and opposite end of brace to outer roof beam with bolts.

Repeat Step 5 for the next 3 braces.

6 Fasten a **roof beam brace** to the main roof beam behind the front gable by placing tab on the end of the brace *between* the roof beams. Align the tab with the *first* hole and fasten the brace with a bolt and nut.

7 Fasten the lower end of the roof beam brace to the track support with a bolt and nut.

Spread Two Halves of Roof Beams

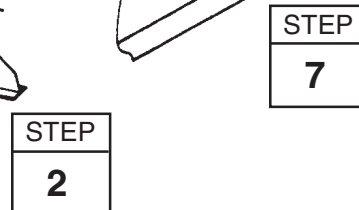
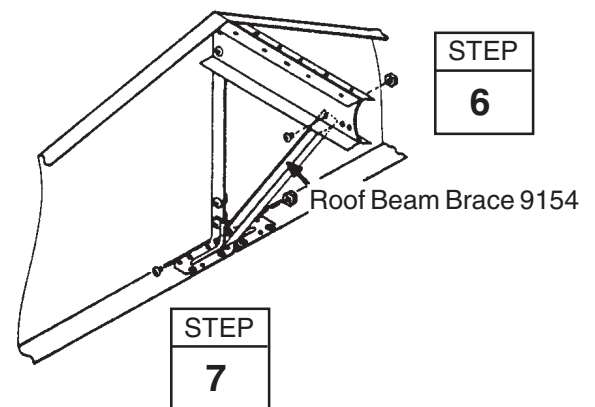
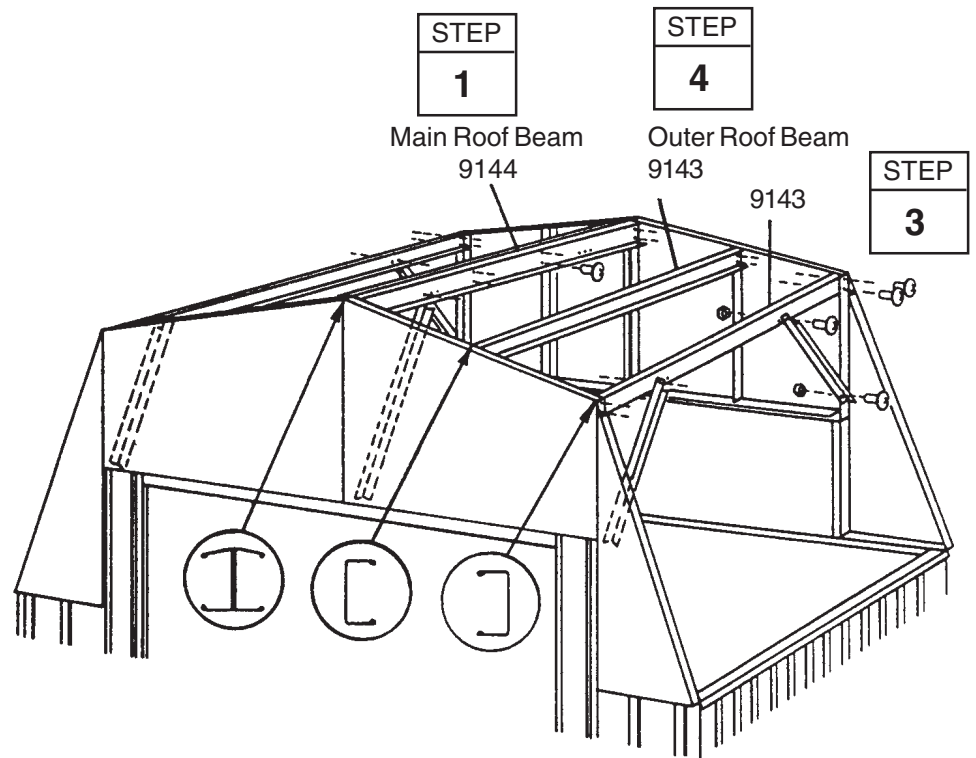
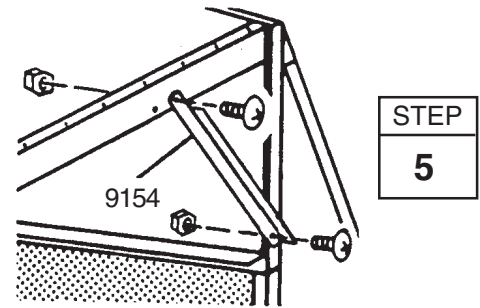
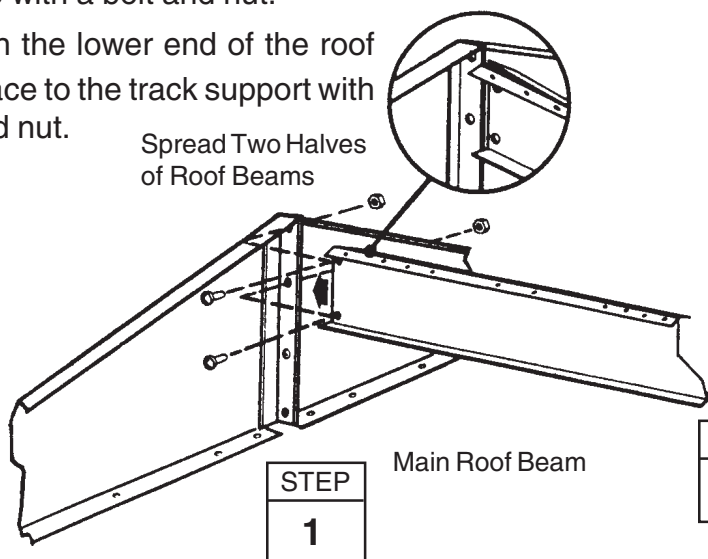

Step 10

E23

● Parts Needed For ● Right Roof Panel

● 9020 Right Roof Panel (1)

Installing the roof panels is best done with a step ladder. Begin installing roof panels at the back right corner of the building. Each screw and bolt in the roof requires a washer.

NOTE

Measure the building diagonally again and make adjustments to make sure the building is square. This will make the roof panels fit better, and holes will align.

1 Locate all the roof panels by their numbers and place them on the ground alongside the building in their proper positions.

STEP
1

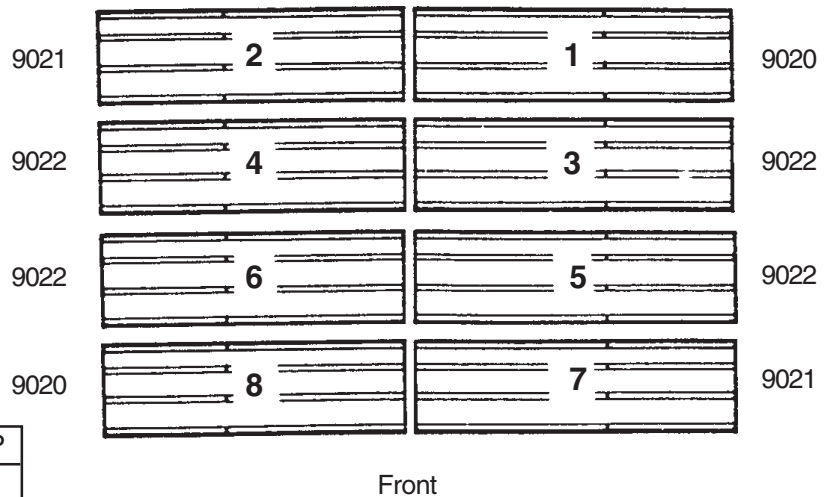

2 Position a **right roof panel** at the back right corner and fasten to the gable and roof beams using screws as shown. *Do not fasten the lower end of the panels to the side eave channel at this time.*

Hint: Follow the fastener sequence shown, for proper alignment.

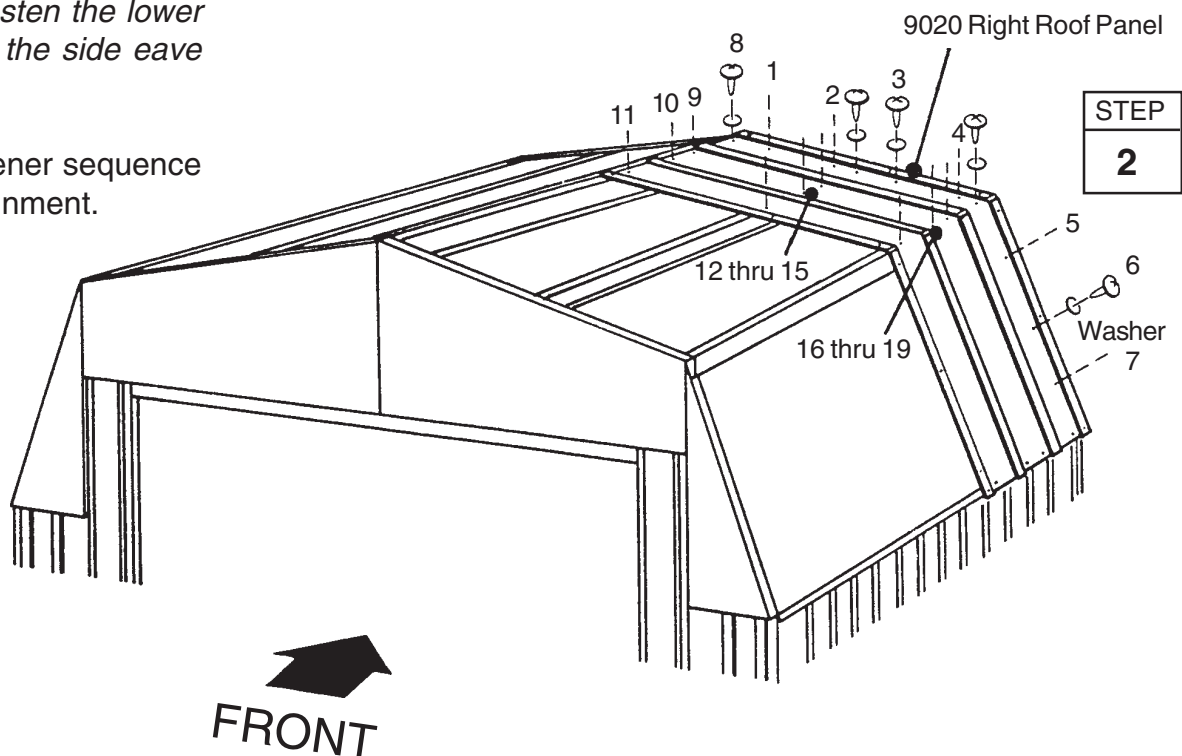

STEP
2

Step 11

E24

● Parts Needed For ● Roof Assembly

- 9021 Left Roof Panel (1)
- 9022 Main Roof Panel (2)

1 Install a **left roof panel** at the left rear corner of the roof.

2 Install remaining **main roof panels** and **right** and **left roof panel** in the sequence and positions shown on previous page. Follow fastener sequence and instructions in Steps 11 & 12 while fastening roof panels.

NOTE

Narrow roof panel rib (with bead on it) is always overlapped by wide rib of adjacent panel

3 Cover the joint at the peak with weather stripping tape. Unroll the tape and press it down over the opening at the ridge as you install each roof panel. Do not cut the tape until entire roof is completed.

4 Cut the **weather stripping tape** into 28 pieces, each piece being about 3" long. Press 26 pieces firmly over the notched areas of the roof panels.

5 At the top roof beam end of panels, fasten 2nd roof panel overlap with a bolt and nut. Press 2 pieces over heads of bolts. Fasten breaks in roof as shown with bolts and nuts.

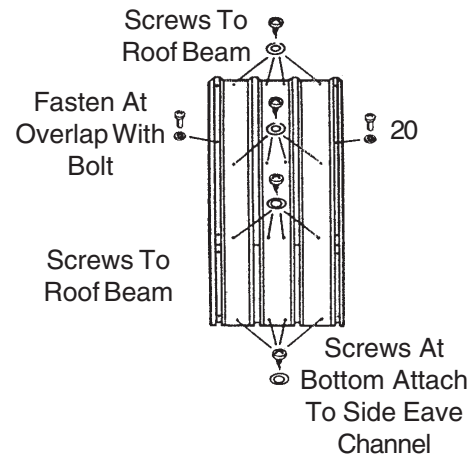

STEP
3

STEP
1

9021 Left Roof Panel

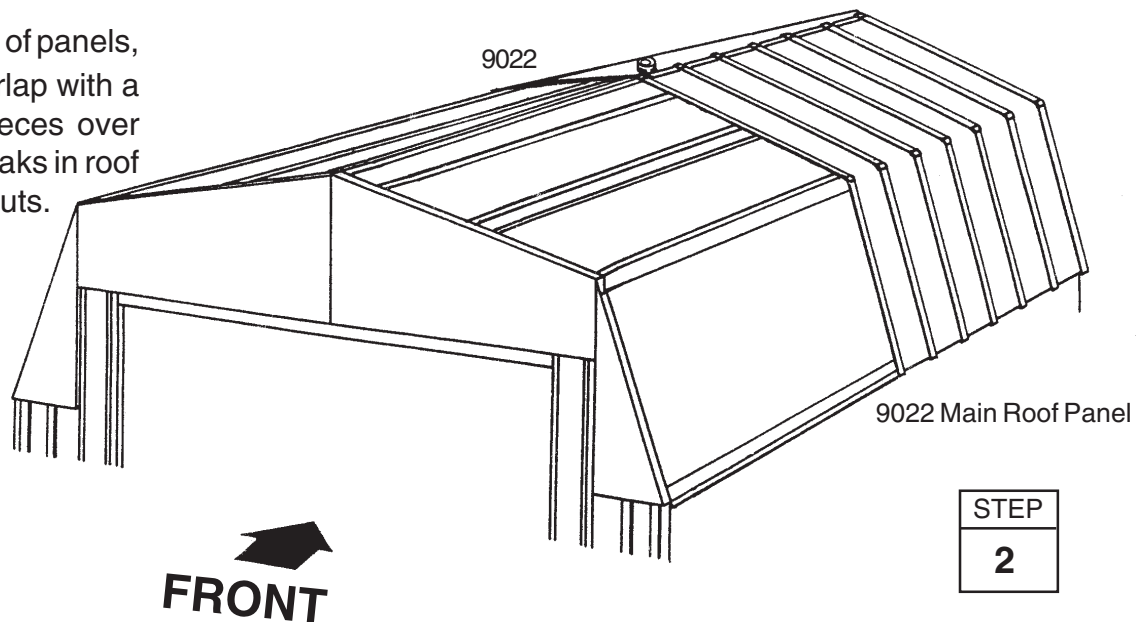

STEP
2

Step 12

E25

● Parts Needed For ● Roof Assembly

- 9022 Main Roof Panel (2)
- 9021 Left Roof Panel (1)
- 9020 Right Roof Panel (1)

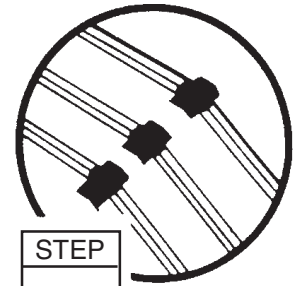

STEP
4

NOTE
If roof beam holes do not line up with the roof panel holes, shift the building from left to right. If this does not help, your building may not be level. Shim the corners until holes line up.

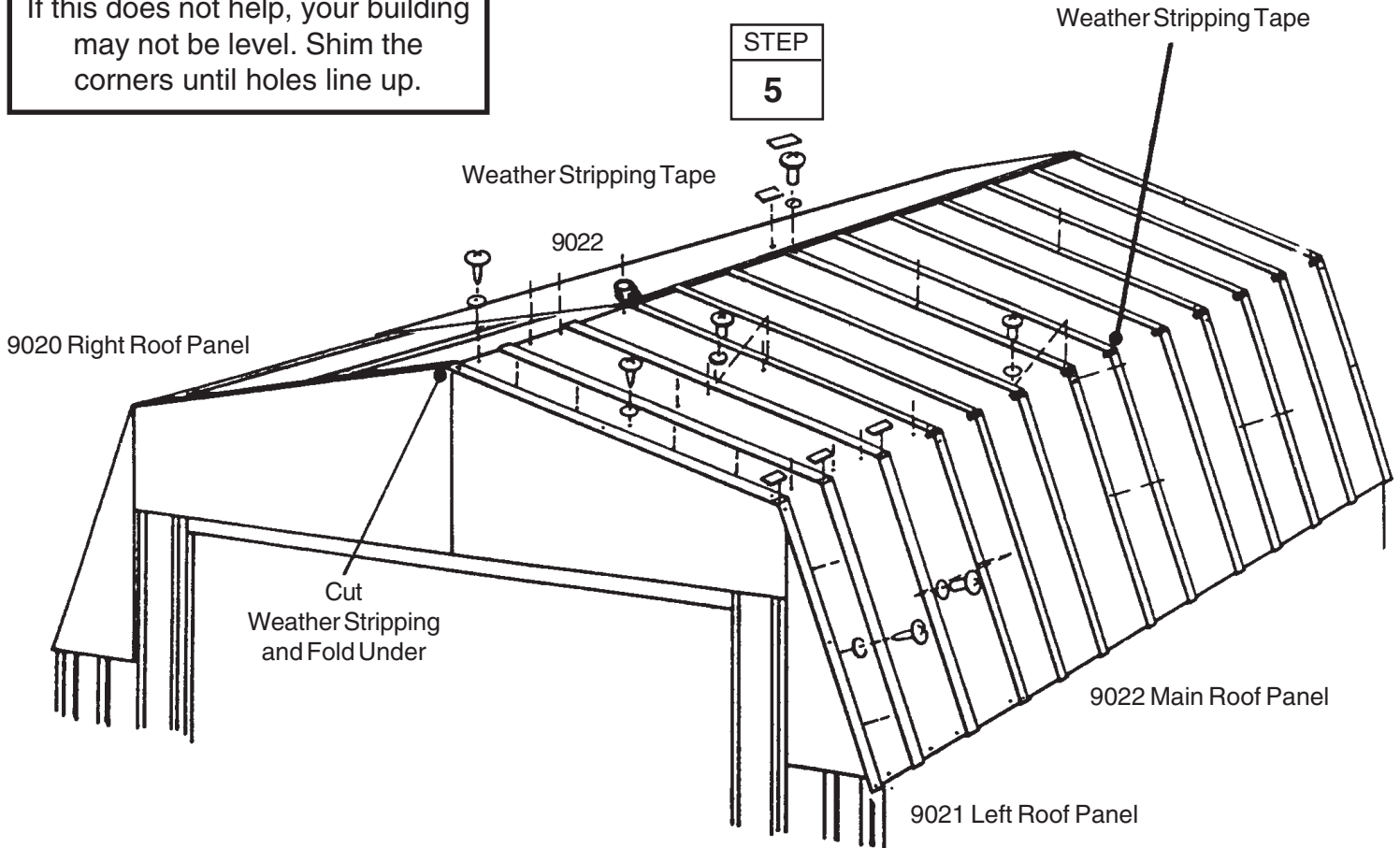

Step 13

E26

● Parts Needed For ● Ridge Cap/Hip Trim

- 5223 Ridge Cap (1)
- 9036 Hip Trim (2)

1 Install the **ridge cap** on the completed roof section using bolts. Do not fasten the ends of the ridge cap until instructed to do so later.

2 Fasten the lower end of the panels to the side eave channel using screws and washers.

3 Fasten **hip trim** at the breaks in roof using bolts, washers and nuts. Do not fasten end of trim at this time.

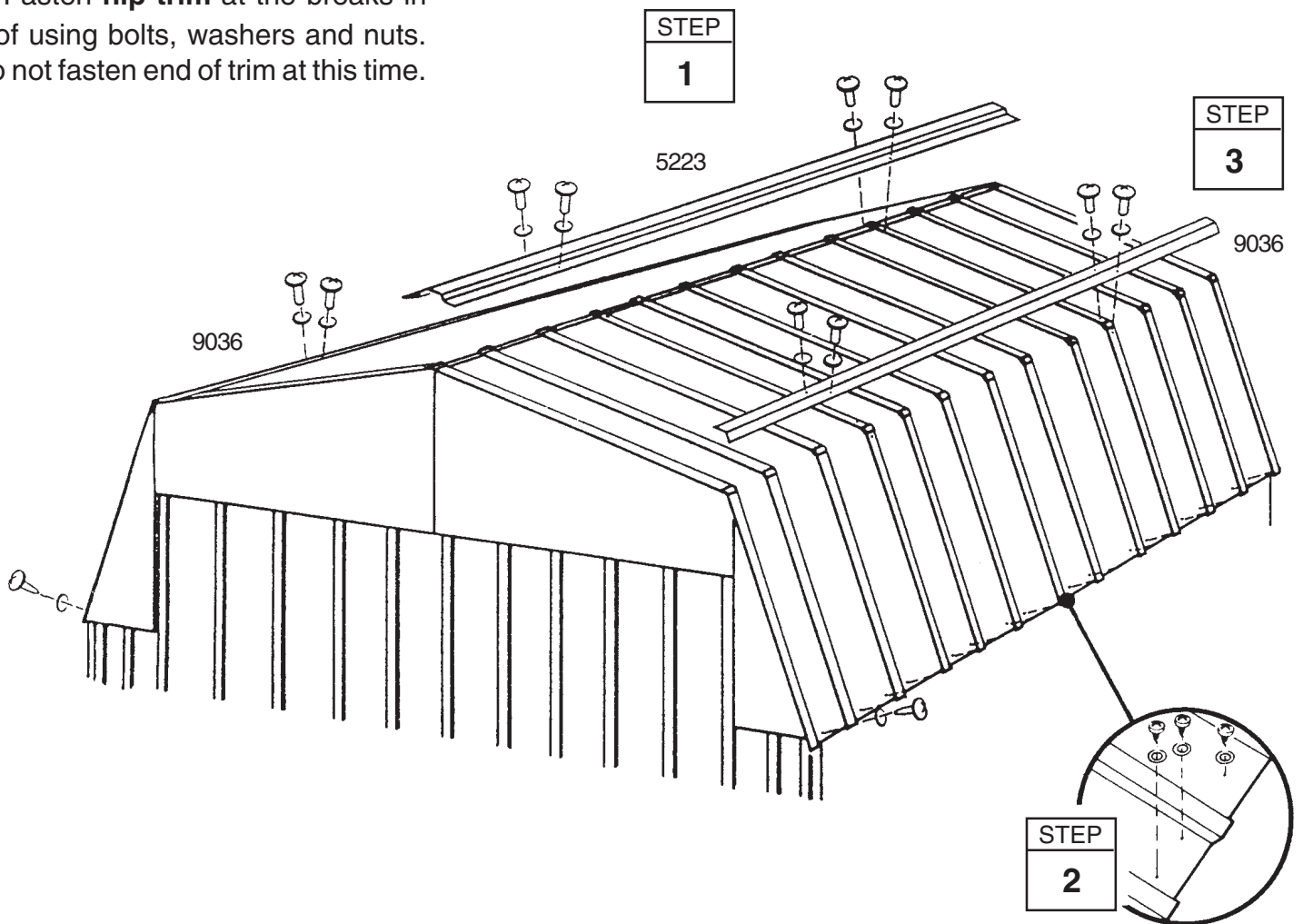

Step 14

E27

● Parts Needed For ●
Side Roof Trim

● 5219 Side Roof Trim (2)

1 Attach the **side roof trim** to the lower end of the roof panels on each side of the building using screws at each panel overlap. Do not fasten the ends of the side roof trim until the next step.

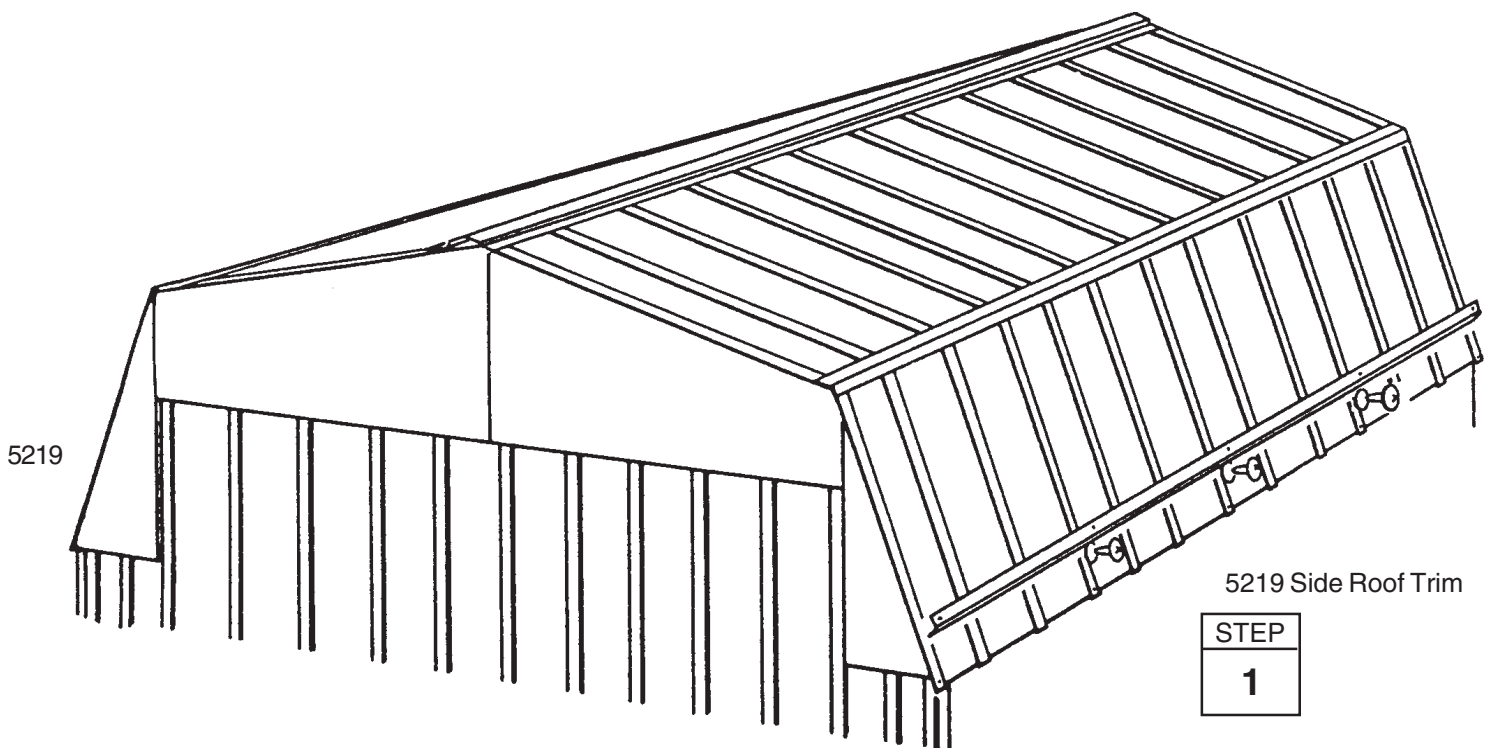

Step 15

E28

● Parts Needed For ● Roof Trim & Caps

- 9035 Left Roof Trim (2)
- 9034 Right Roof Trim (2)

1 Position **left** and **right roof trim** to the ends of roof, noting that trim slips under ridge cap and hip trim, but fits on top of side roof trim.

2 Fasten roof panel rib, trim, **peak cap** and ridge cap together using bolts and nuts. Fasten the remaining peak cap in the same manner.

3 Fasten **facia caps** to the hip trim in the same manner.

4 Using your thumb and index finger, overbend the bottom flange of the side roof trim at the corner inward enough so the **right and left roof trim caps** fit onto right and left corners where trims meet. Fasten trim to side trim using a screw.

5 Fasten the roof trim caps to the side trim using a screw.

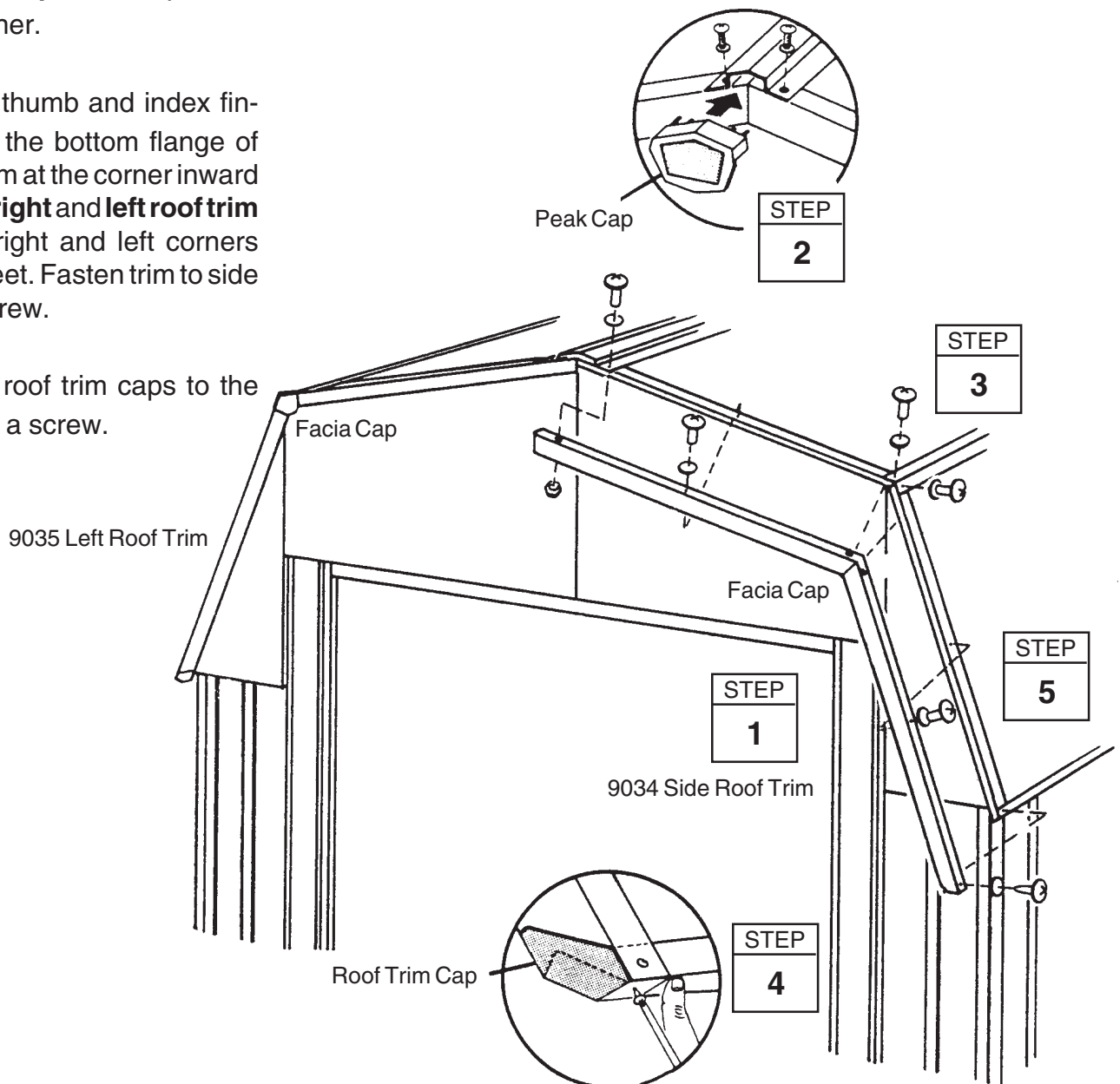

Step 16

E29

● Parts Needed For ● Attic Assembly

- 9038 Horizontal Attic Channel (4)
- 9039 Horizontal Attic Channel (1)
- 9048 Vertical Attic Channel (1)
- 9040 Vertical Attic Channel (2)

1 Bend tab at one end of **vertical attic channel** (long) inward. Insert opposite end between main roof beams, align holes and attach with bolts and nuts.

2 Fasten tab end of **vertical attic channels** to flat side of outer roof beams using bolts and nuts.

3 Attach **horizontal attic channel** (long) to the vertical channels using bolts and nuts. Holes in wide side toward rear.

4 At four locations, position **horizontal attic channels** over long horizontal channel and fasten using bolts and nuts. Fasten opposite ends over rear wall angle using screws.

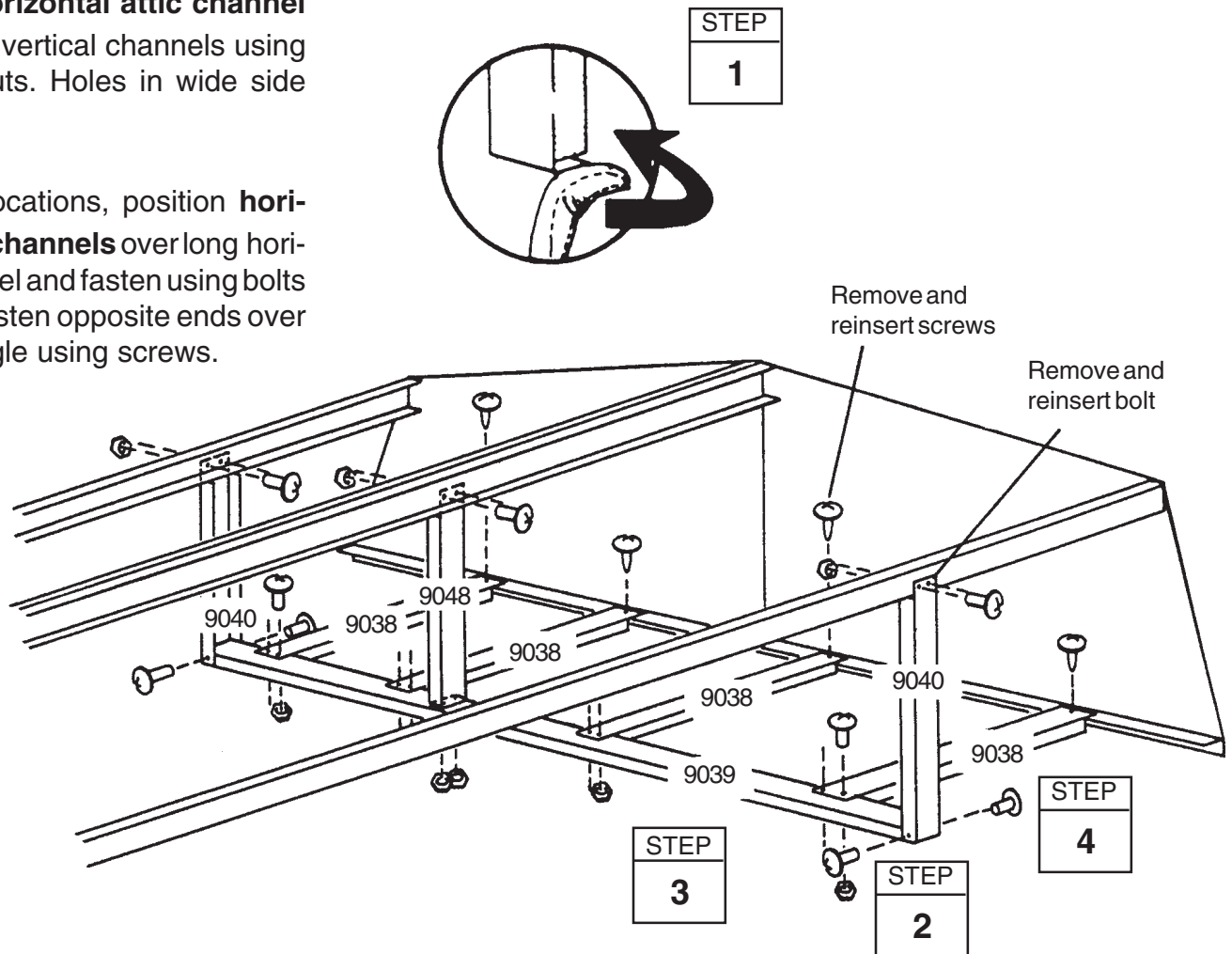

The upper storage area attic is engineered to support tools, aluminum furniture, lightweight articles etc. It is not designed to support extremely heavy material such as concrete blocks, bags of cement or sand, or a large volume of lumber, etc. **CAUTION** should be kept in mind at all times as to the weight of the material being stored on this attic. The manufacturer assumes no responsibility for failure or personal injury.

Step 17

E30

● Parts Needed For ● Door Assembly

- 10481 Left Door (2)
- 10480 Right Door (2)
- 10504 Horizontal Door Brace (6)
- 10507 Secondary Door Track (2)

1 Position **door slides** onto the legs, from the end of door track, as shown in the end view.

2 Put a **horizontal door brace** onto the bottom edge of all doors, and fasten with **lower door guides** in corners, using bolts and nuts.

3 Put a horizontal door brace onto the top edge of 1 **right** and 1 **left door**, fastening through center hole only, with a bolt and nut.

4 From inside the building, put the bottom of the left door (without top brace), on your right when inside the building, behind door jamb into the 1st front frame track.

5 Position the top of the door so that the holes in door line up with the middle holes in the 1st two door slides, in from end of track.

6 Position a **secondary door track** to the inside top of left door. Fasten track and door to the 1st two slides using #10Bx1/2" screws. Fasten secondary track to the 3rd slide using #10Bx1/2" screws.

7 Insert 2 slides into secondary door track.

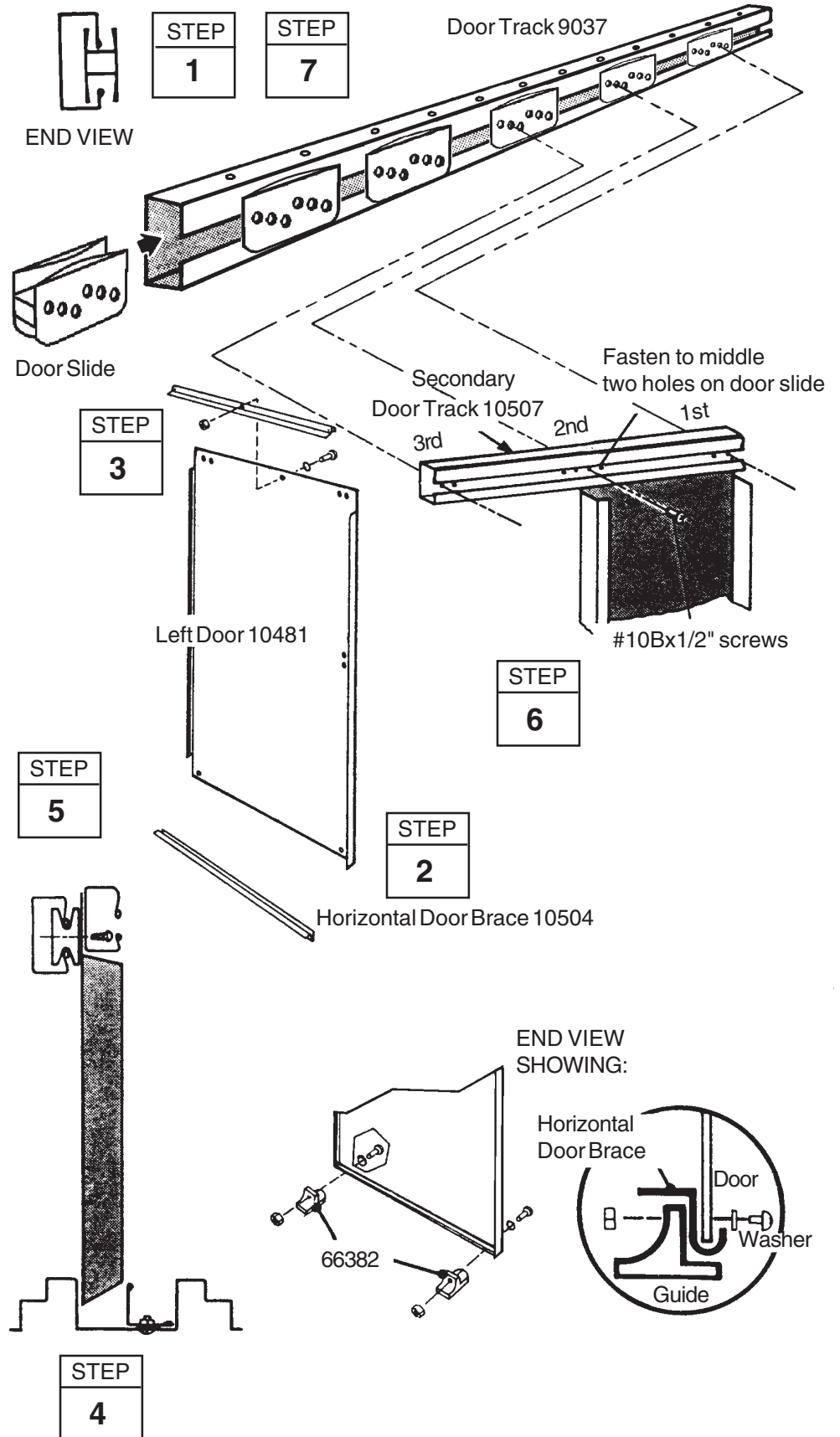

Step 17 Continued

Door Installation & Adjustment

E31

8 Put the bottom of **left door** (with top brace) into the second channel of the front floor frame. Position the top of the door so that the holes in the door line up with the holes in the door slides and fasten as before.

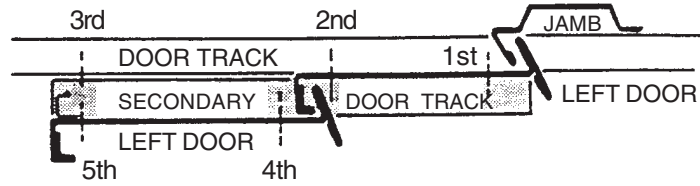

9 Repeat Steps 2 through 8 for the **right doors**.

10 Attach the **handle** to the right and left inner doors using bolts.

11 Push **door plugs** into holes in right and left outer doors.

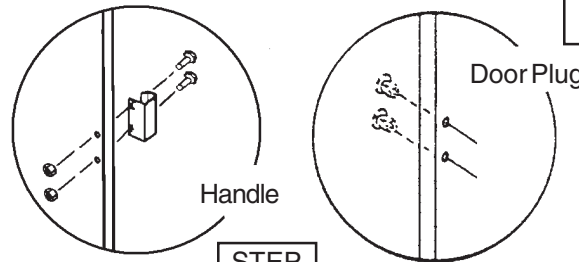

STEP
11

STEP
10

NOTE

The holes in the door slides allow you to adjust the doors. Place the door in the middle holes.

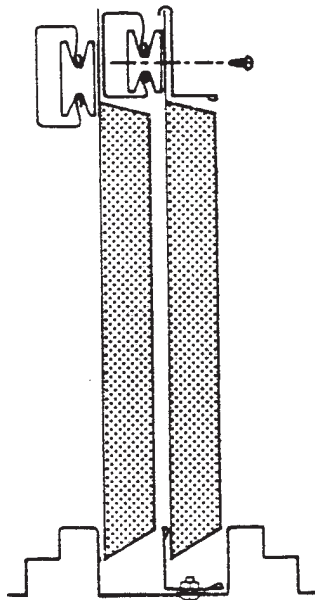

STEP
8

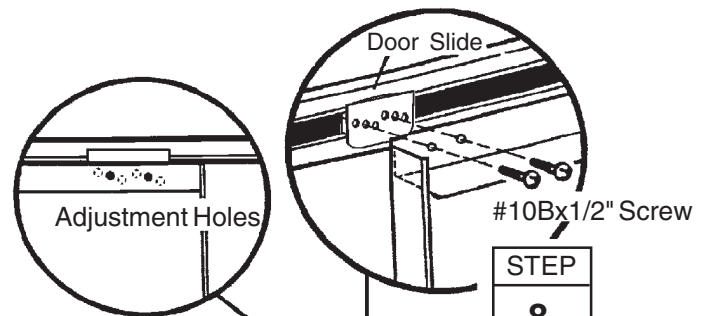

STEP
8

STEP
9

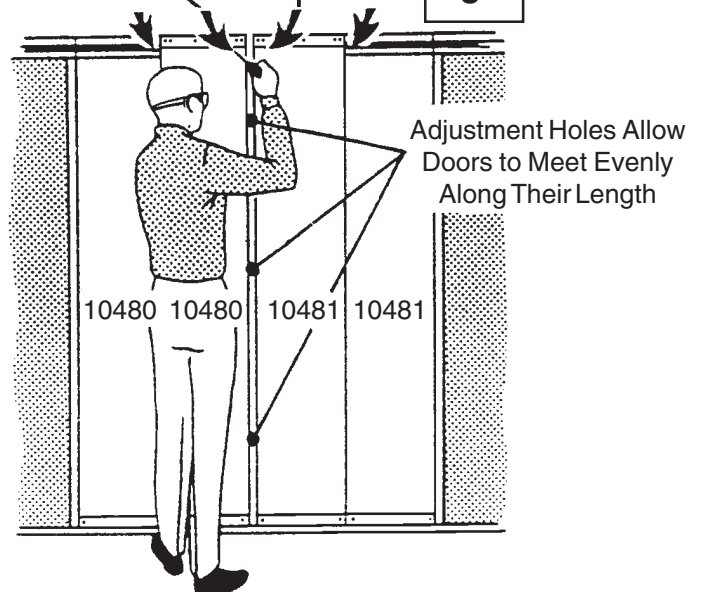

SOME FACTS ABOUT RUST

Rusting is a natural oxidizing process that occurs when bare metal is exposed to moisture. Problem areas include screw holes, unfinished edges, or where scrapes and nicks occur in the protective coating through normal assembly, handling and use. Identifying these natural rusting problem areas and taking some simple rust protection precautions can help to stop rust from developing, or stop it quickly as soon as it appears.

1. Avoid nicking or scraping the coating surface, inside and out.
2. Use all the washers supplied. In addition to protecting against weather infiltration, the washers protect the metal from being scraped by the screws.
3. Keep roof, base perimeter and door tracks free of debris and leaves which may accumulate and retain moisture. These can do double damage since they give off acid as they decay.
4. Touch up scrapes or nicks and any area of visible rust as soon as possible. Make sure the surface is free of moisture, oils, dirt or grime and then apply an even film of high quality touch-up paint.