

Storage Shed

Patent #416.091

OWNER'S MANUAL / Instructions for Assembly Size 8'x 6' with "Extension Kits"

Ver: 1.2

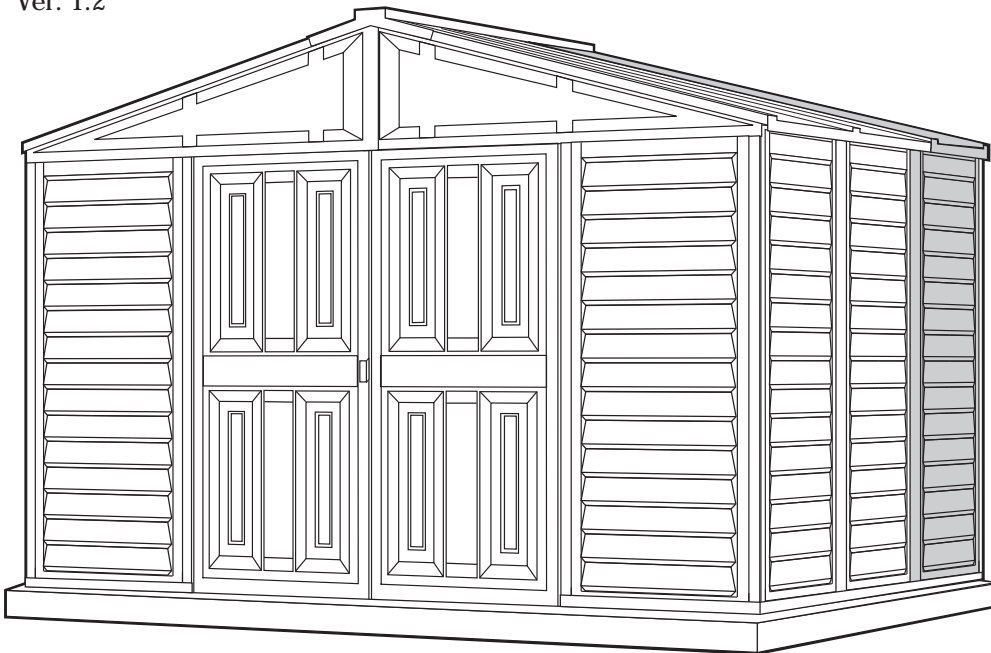

Customer
Service Hotline
(800) 483-4674
www.uspolymersinc.com

Your Total Solution To maintenance Free Storage Sheds.

- All Weather Durable PVC
- Won't Dent, Rust, Rot or Mildew
- Never Needs Painting
- 61" Wide Double Doors
- Easy Assembly
- High Wind Tested
- Snow Load Tested 60lbs/sqft
- Pad Lock Ready (Lock not included)
- Wooden or Cement Foundation Needed

PART 1

ASSEMBLING SHED WITH EXTENSION KIT

PART 2

ADDING EXTENSION KIT TO EXISTING SHED

Note: For shed with extension use this manual only.

Available Kits

- Foundation Kit Available
- Modular 2.5' Extension Kits Available
- 8'x6' Window Kits Available

Requires two people and takes about 4-5 hours for Installation.

Call us for any missing or damaged parts.
Do not return to the store.

Duramax Storage Shed Limited Fifteen Year Warranty

U.S. Polymer Inc. will send a replacement part free of charge, in the event of material defects and or workmanship for a period of fifteen years from the date of purchase.

This warranty is extended only to the original purchaser. A purchase receipt or other proof of date of original purchase will be required before warranty service is rendered. In no event shall we pay the cost of flooring, labor, installation or any other costs related thereto.

This warranty only covers failures due to defects in material or workmanship which occurs during normal use and does not extend to color change arising due to normal weathering or to damage resulting from misuse or neglect, commercial use, failure to follow assembly instructions and the owner's manual (including proper anchoring of the shed), painting, forces of nature and other causes which is beyond our control.

Claims under this warranty must be made within the warranty period by calling 1-800-483-4674 or mail in a dated sales slip and clear photograph of the part to:

U.S. Polymers, Inc.
6915 Slauson Avenue
Commerce, CA 90040

We reserve the right to discontinue or change components. If a component has been discontinued or is not available, U.S. Polymers, Inc. reserves the right to substitute a component of equal quality as may be compatible.

Limits and Exclusions

There are no express warranties except as listed above. The warrantor shall not be liable for incidental or consequential damages resulting from the use of this product, or arising out of any breach of this warranty.

All express warranties are limited to the warranty period set forth above. Some states do not allow the exclusion or limitation on how long an implied warranty lasts, so the above limitations may not apply to you.

This warranty gives you specific legal rights and you may also have other rights which vary from state to state and country to country.

Parts List

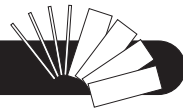

Note: Check all parts prior to installation.

ACCESSORIES

CODE	DESCRIPTION	QTY	CODE	DESCRIPTION	QTY
B1LB	FRONT 'U' CHANNEL LEFT	1	FDCL	DOOR COLUMN FITTING LEFT	1
B1RB	FRONT 'U' CHANNEL RIGHT	1	FDCR	DOOR COLUMN FITTING RIGHT	1
B2B	SIDE 'U' CHANNEL	2	FCC	CORNER COLUMN FITTING	4
B21	BACK 'U' CHANNEL LEFT	1	FMC	MIDDLE COLUMN FITTING	4
B22	BACK 'U' CHANNEL RIGHT	1	FCB	CENTER BAND FITTING	4
CMB	MIDDLE COLUMN	4	RJ	90 DEGREE JOINT	4
CCB	CORNER COLUMN	4	PPG	ROOF PLUG	64
CDLB	LEFT DOOR COLUMN	1	PWS	ROOF PLUG WASHER	64
CDRB	RIGHT DOOR COLUMN	1	PIN	ROOF PIN	64
CB1B	FRONT CENTER BAND	2	EPS	END PLUG SQUARE	4
CB2B	SIDE CENTER BAND	2	S1	DIA. 4.2 x 16mm. (5/32" x 5/8")	168
CB3SB	BACK CENTER BAND SHORT	1	S2	DIA. 4.2 x 32mm. (5/32" x 1 1/4")	
CB3LB	BACK CENTER BAND LONG	1	S3	M4 x 10mm. (M5/32" x 3/8")	6
CB4B	FRONT CROSS CENTER BAND	2			
RS1B	RS1 ROOF STRUCTURE	4			
RS2B	RS2 ROOF STRUCTURE	4			
RS3B	RS3 ROOF STRUCTURE	2			
RS4B	RS4 ROOF STRUCTURE	2			
RS5B	RS5 ROOF STRUCTURE	4			
RS8B	RS8 ROOF STRUCTURE SUPP. LONG	4			
RS9B	RS9 ROOF STRUCTURE SUPP. SHORT	4			
RS10B	RS10 ROOF STRUCTURE SUPPORT	2			
RS11B	RS11 ROOF STRUCTURE SUPPORT SHORT	1			
RS14B	SAGGING SUPPORT	8			
DSH	DOOR STOPPER HORIZONTAL	1			
SP↑	SIDE PANEL	7			
FPLB	FACIA PANEL LEFT	2			
FPRB	FACIA PANEL RIGHT	2			
RP↑	ROOF PANEL	4			
RRS	RIDGE COVER	2			
DL	LEFT DOOR	1			
DR	RIGHT DOOR	1			
FSP↑	FRONT SIDE PANEL	2			

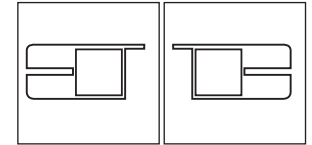

LEFT DOOR COLUMN (CDLB) RIGHT DOOR COLUMN (CDRB)

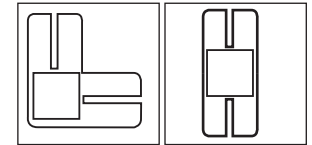

CORNER COLUMNS (CCB) MIDDLE COLUMNS (CMB)

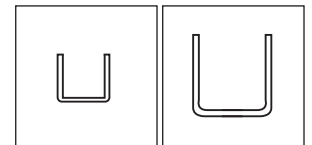

ROOF STRUCTURES (RS - 1B, 3B, 8B, 9B) (CB - 1B, 2B, 3B, 4B) U-Channels (B1LB)(B1RB) (B21) (B22) (B2B)

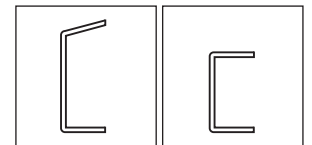

ROOF STRUCTURE (RS5B) DOOR STOPPER (DSH)

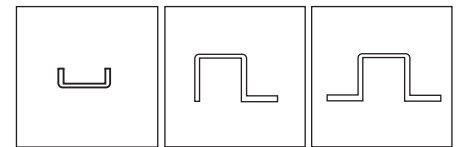

SAGGING SUPPORT (RS14B) ROOF SUPPORT (RS10B) ROOF SUPPORT (RS2B) ROOF SUPPORT (RS4B) (RS11B)

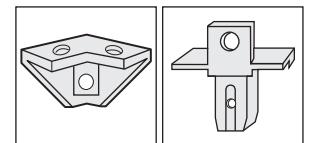

CENTER BAND FITTING (FCB) MIDDLE COLUMN FITTING (FMC)

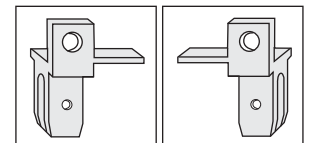

DOOR COLUMN FITTING (FDCL) DOOR COLUMN FITTING (FDCR)

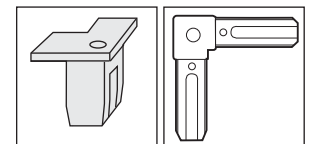

CORNER COLUMN FITTING (FCC) PVC 90 DEGREE JOINT (RJ)

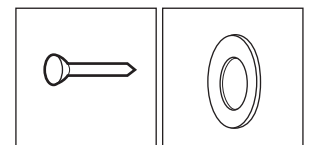

ROOF PIN (PIN) ROOF PLUG WASHER (PWS)

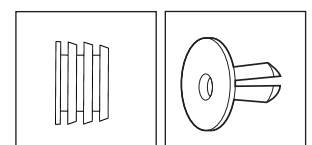

END PLUG SQUARE (EPS) ROOF PLUG (PPG)

Tools You Will Need

- Cordless Drill - Philips Head
- Hammer or Rubber mallet
- Carpenters Square
- 8' Step Ladder
- Adjustable pliers
- Level - 3ft.
- Tape Measure
- Caulk Gun
- Waterproof Clear Silicon
- Sealant
- Hand Gloves

One Extension Parts List

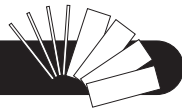

Note: Check all parts prior to installation.

CODE	DESCRIPTION	QTY
EXTL	EXTENSION 'U' CHANNEL LEFT	1
EXTR	EXTENSION 'U' CHANNEL RIGHT	1
CMB	MIDDLE COLUMN	2
CB3LB	BACK CENTER BAND LONG	2
RS3SB	RS3 ROOF STRUCTURE SHORT	2
RS4B	RS4 ROOF STRUCTURE	2
RS6B	RS6 ROOF STRUCTURE	2
RS7B	RS7 ROOF STRUCTURE	2
RS11B	RS11 ROOF STRUCTURE SUPPORT SHORT	1
RS14B	SAGGING SUPPORT	4
SP↑	SIDE PANEL	2
RP↑	ROOF PANEL	2
RRS	RIDGE COVER	1

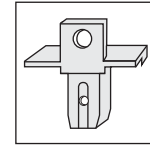

MIDDLE COLUMN FITTING (FMC)

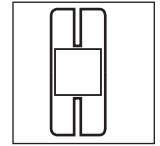

MIDDLE COLUMNS (CMB)

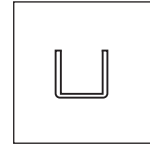

ROOF STRUCTURES (RS3SB) (CB3LB)

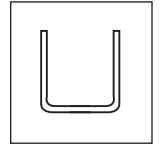

U-Channels (EXTL) (EXTR)

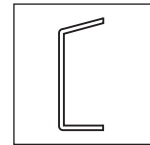

ROOF STRUCTURE (RS6B) (RS7B)

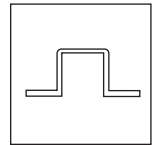

ROOF SUPPORT (RS4B) (RS11B)

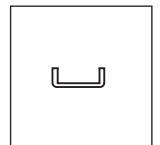

SAGGING SUPPORT (RS14B)

ACCESSORIES

CODE	DESCRIPTION	QTY
FMC	MIDDLE COLUMN FITTING	2
PPG	ROOF PLUG	16
PWS	ROOF PLUG WASHER	16
PIN	ROOF PIN	16
S1	DIA. 4.2 x 16mm. (5/32" x 5/8") SHEET METAL SCREW	36
S3	M4 x 10mm. (M5/32" x 3/8") MACHINE SCREW WITH NUT	30

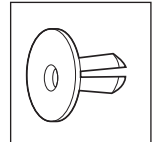

ROOF PLUG (PPG)

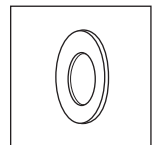

ROOF PLUG WASHER (PWS)

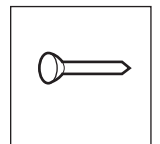

ROOF PIN (PIN)

Exploded View with One Extension

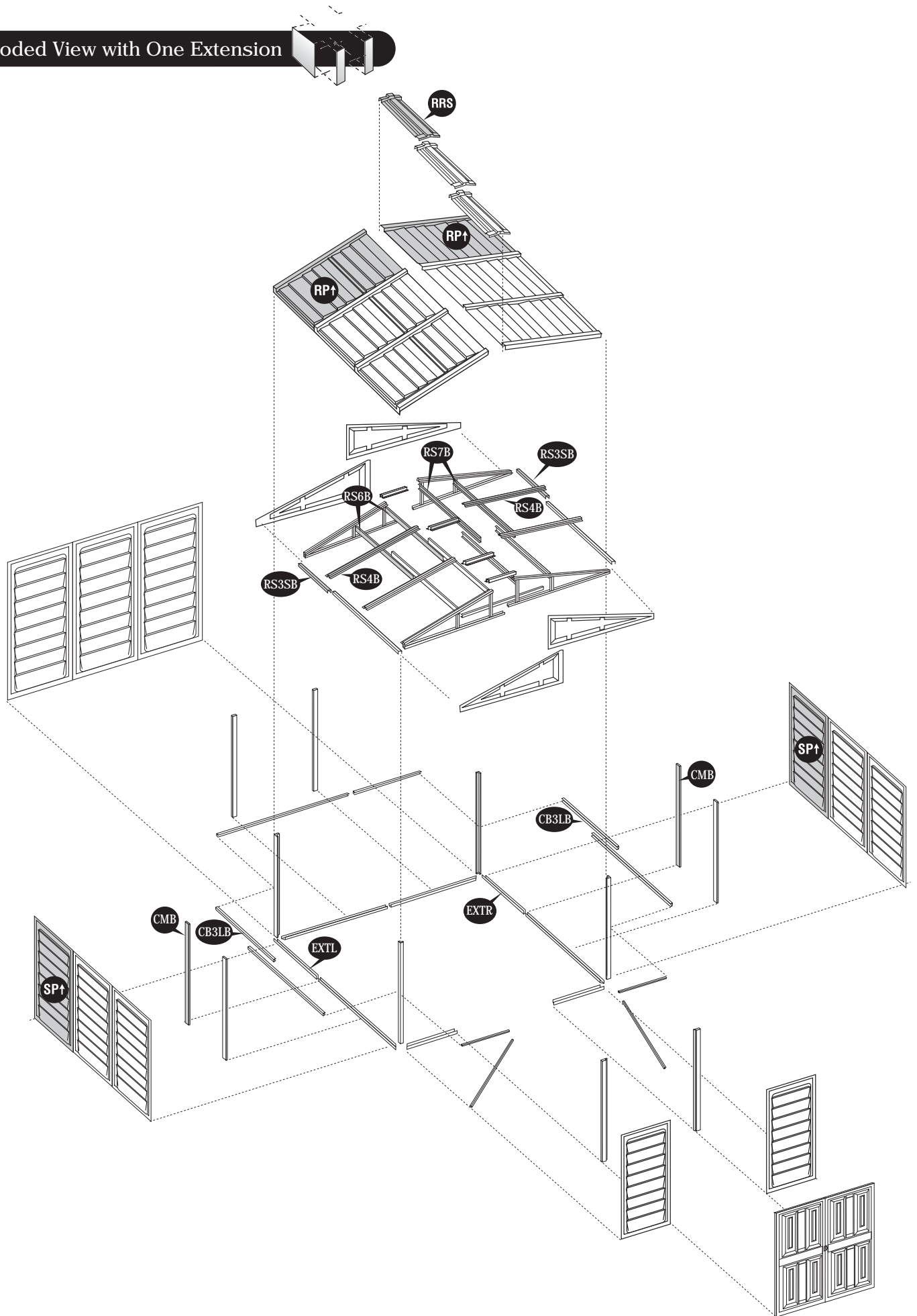

A. Foundation & Base Frame

Note: It is important that these instructions are followed step by step.

DuraMax must be installed on a level wooden platform or a level concrete foundation.



Wooden platform is extra and is not included. Don't install under windy conditions.

Parts needed:

- (1) U channel Front left (B1LB)
- (1) U channel Front right (B1RB)
- (1) U channel Back (B21)
- (1) U channel Back (B22)
- (2) U channel Side (B2B)
- (22) Dia. 4.2 x 16mm Screws (S1)

Parts needed For Each Extension:

- (1) Extn. U channel left (EXTL)
- (1) Extn. U channel right (EXTR)
- (6) Dia. 4.2 x 16mm Screws (S1)

1. Use pressure treated wood studs 2" x 4" (5 x 10cm) to build a foundation structure that has an outside dimension of 65" x 96" (1651mm x 2438.4mm).

1a. Use pressure treated wood studs 2" x 4" (5 x 10cm) to build a foundation structure that has an outside dimension of 32" x 96" (812.8mm x 2438.4mm) for each extension.

OR 1b. Use pressure treated wood studs 2" x 4" (5 x 10cm) to build a foundation structure that has an outside dimension of 97" x 96" (2463.8mm x 2438.4mm) for shed with one extension.

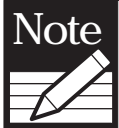

Lay 2" x 4" (5cm x 10cm) Flat

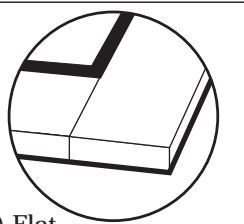

2. Using exterior grade CDX 3/4" (19mm) plywood, cut and fit together the sheets to form solid plywood floor as shown. Foundation must be square and level.

3. Start with U-Channel bases (B21) & (B22) to insure a quick and accurate layout. Position all bases (B1LB, B1RB, B2B) on wood foundation. It is critical that you allow 61 1/4" (1556mm) between front bases (B1RB) and (B1LB) for door placement. Measure in all directions as shown in fig. 1. Make sure the U-channel assembly is a perfect square.

3a. For each extension add one (EXTL) & (EXTR) in the back side moving (B21) & (B22) backwards.

1

PART 1: Assembling Shed With Extension Kit

Wooden Platform (Not Included)

The following are a list of lumber and sizes you will need.

Pressure Treated - Wood Studs:	Exterior Grade (CDX):
4ea 2" x 4" x 89" (50 x 88.9 x 2260.6mm)	3/4" 19mm plywood
2ea 2" x 4" x 65" (50 x 88.9 x 1651mm)	1ea 3/4" x 48" x 96" (19 x 1219.2 x 2438.4mm)
	1ea 3/4" x 17" x 96" (19 x 431.8 x 2438.4mm)

L-Brackets: 4ea

Wooden Platform for Each Extension (Not Included)

The following are a list of lumber and sizes you will need.

Pressure Treated - Wood Studs:	Exterior Grade (CDX):
2ea 2"x4"x89" (50 x 88.9 x 2260.6mm)	3/4" (19mm) plywood
2ea 2"x4"x32" (50 x 88.9 x 812.8mm)	1ea 3/4" x 32" x 96" (19x812.8x2260.6mm)

L-Brackets: 4ea

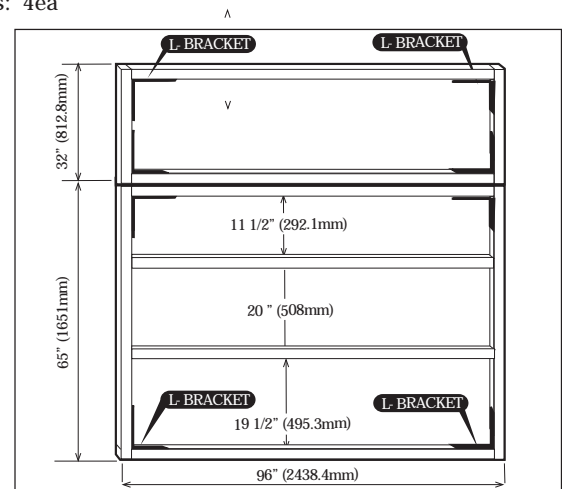

Foundation Structure

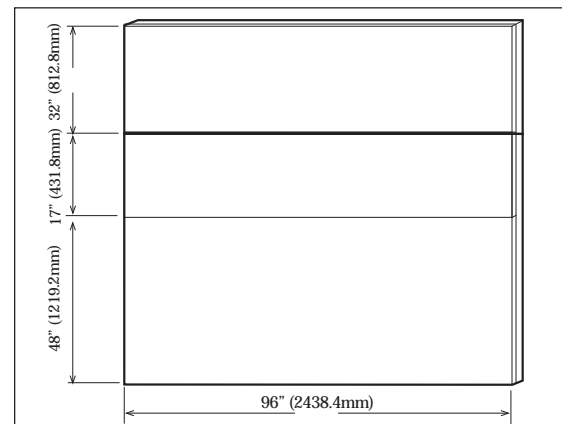

Plywood Floor

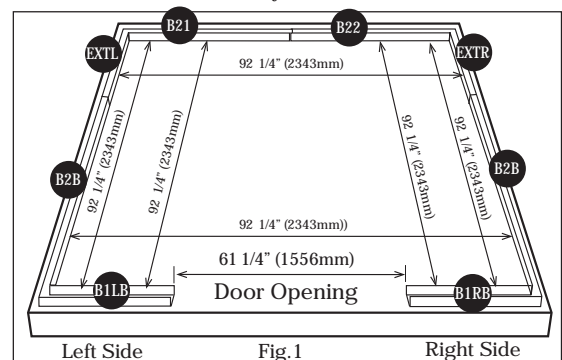

U-Channel Layout

4. Using a carpenter's square, line up all corners. Secure base to wood foundation using (S1) screws

Concrete foundation

4b. (Concrete foundation) Using a carpenter's square, line up corners. Align U-Channel base, mark the concrete at the holes in the base and drill concrete with 1/4" (dia. 6mm) concrete bit to accept anchor bolts to a 1 3/4" (44mm) depth. Replace base and secure with 1/4" x 1 3/8" (M6 x 35mm) anchor bolts (not provided).

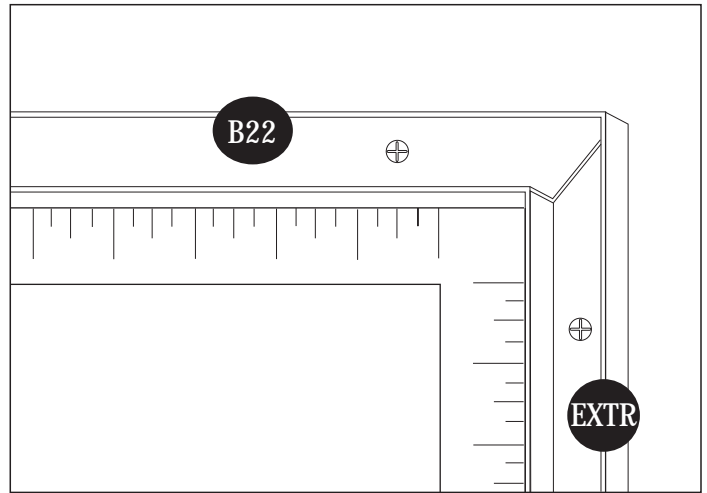

B. Walls & Columns



All panels are clearly marked and care should be taken to use the correct one.

Parts Needed:

- (4) Corner Column (CCB)
- (1) Left Door Column (CDLB)
- (1) Right Door Column (CDRB)
- (4) Middle Column (CMB)
- (7) Side Panels (SP↑)
- (2) Front Side Panels (FSP↑)
- (2) Front Center Band (CB1B)
- (2) Side Center Band (CB2B)
- (1) Back Center Band short (CB3SB)
- (1) Back Center Band long (CB3LB)
- (2) Front cross center band (CB4B)
- (4) Center Band Fitting (FCB)

Parts Needed For Each Extension:

- (2) Middle Column (CMB)
- (2) Side Panels (SP↑)
- (2) Back Center Band long (CB3LB)

1. Slide right door column (CDRB) into the U-Channel Base (B1RB) on the right side of the door. Line up the pre-drilled holes on (CDRB) Column with pre-drilled holes on U-Channel Base. Secure with two (S1) screws from inside.

(See blowup detail fig.1)

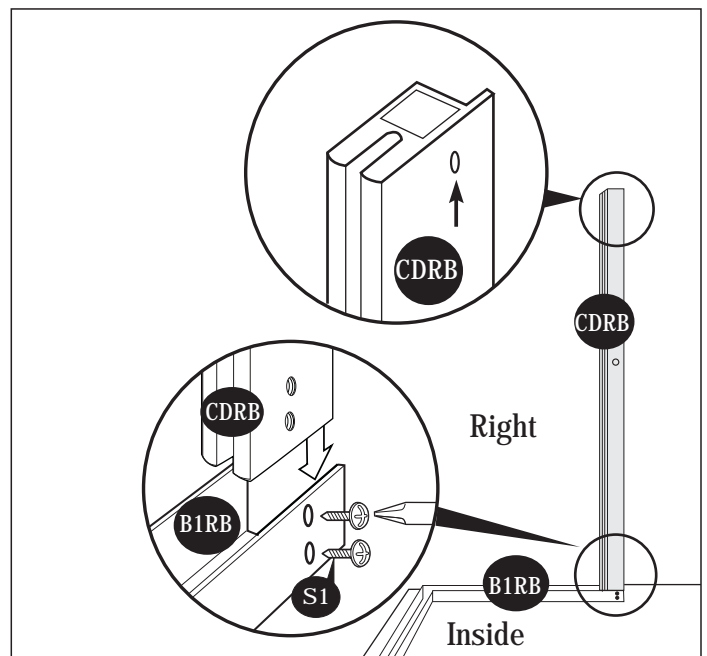

fig.1

2. Insert the front side panel (FSP ↑) into the groove of column (CDRB). Start at the bottom of the panel at an angle then push into place.



Always place panels into frame at an angle on top and slide in sideways and downward for easy insertion.



Make sure panels are right side up with panel shingles facing down. Check the stamped label on top of all panels.

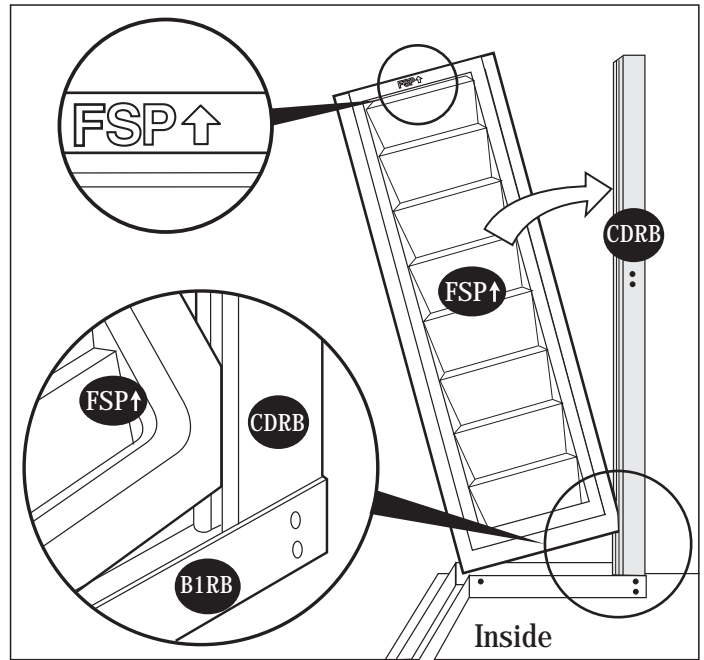
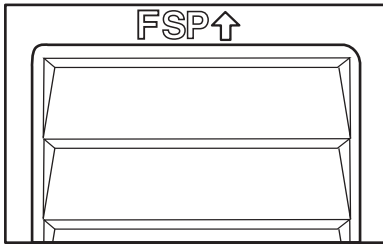

3. Slide corner column (CCB) into side panel (FSP ↑) pushing the column to the side panel.

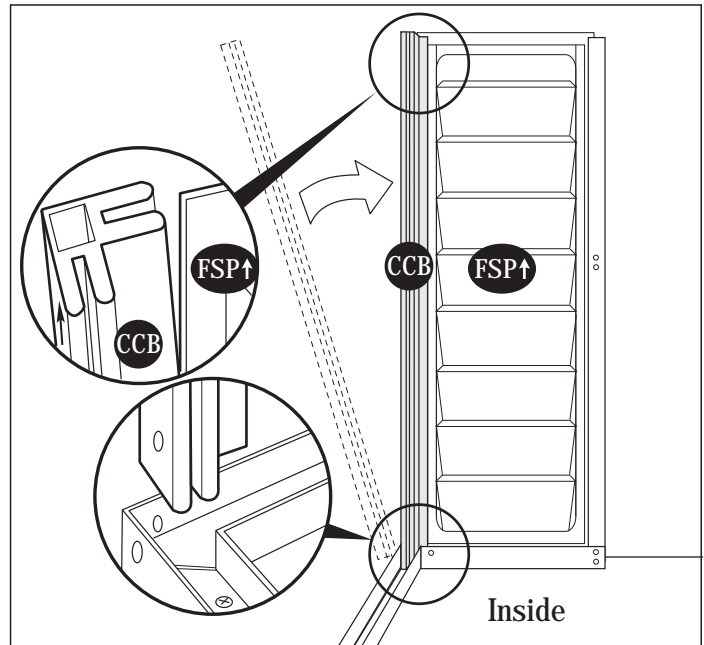

4. Working outside use (S1) screws to secure column to bases (B1RB) and (B2B).

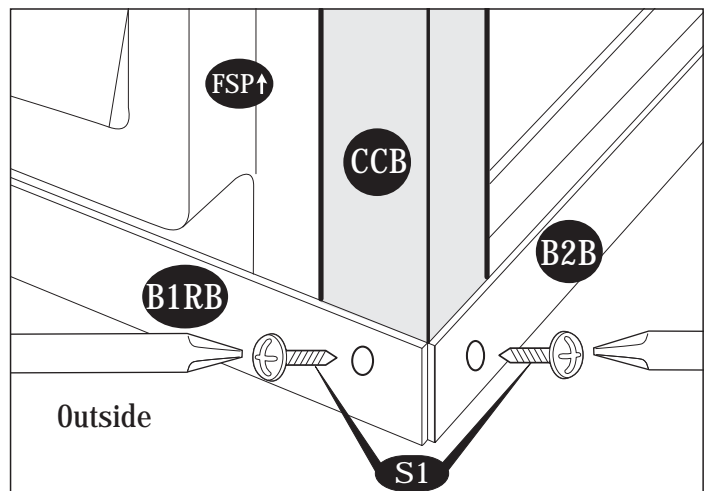

5. To stabilize the front panel attach the front center band right (CB1B) . Start with the center band fitting. Fix to corner column (CCB) with (S2) screws. To continue See figures (fig.1) (fig.2) and (fig.3).



To insure easy assembly Locate the identification number of each part.

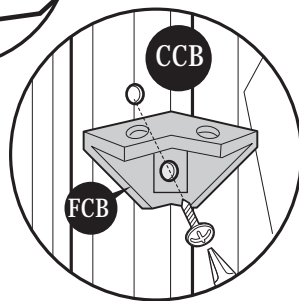
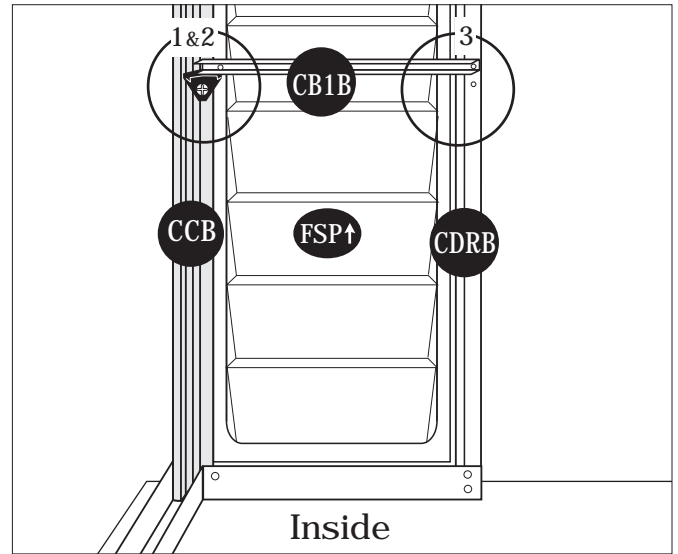
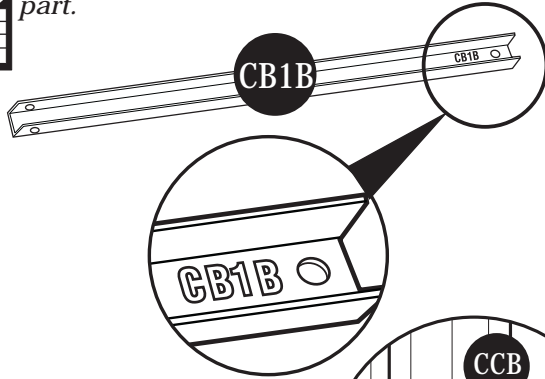

Fig.1: Use (S2) screw. Fix (FCB) to (CCB). Leave it loose.

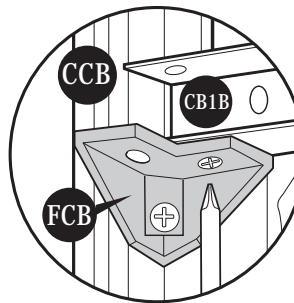

Fig.2: Use (S1) screw. Fix (CB1B) to (FCB)

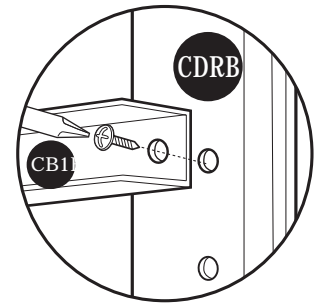

Fig.3: Use (S1) screw. Fix (CB1B) to (CDRB)

6. Attach center band (CB4B) to door column (CDRB) and base channel (B1RB).

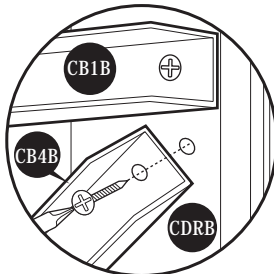

Fig.1: Use (S1) screw. Fix (CB4B) to (CDRB)

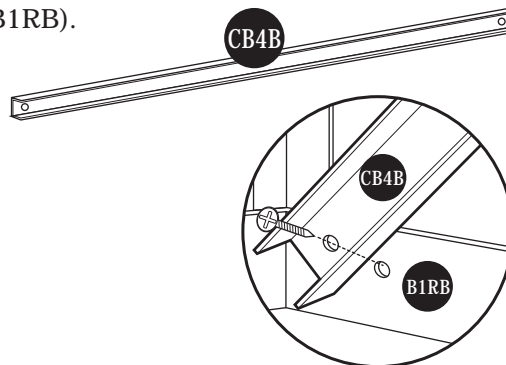

Fig.2: Use (S1) screw. Fix (CB4B) to base (B1RB)

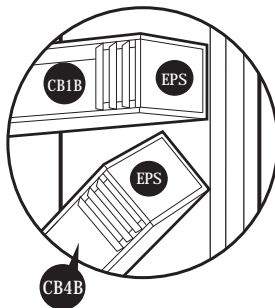
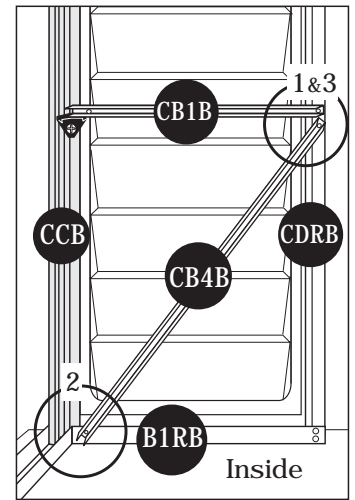
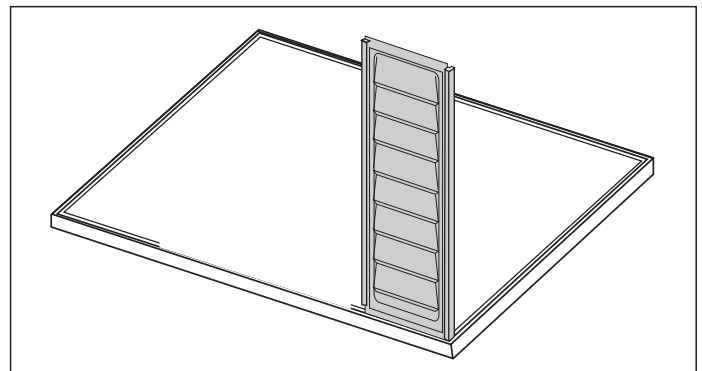
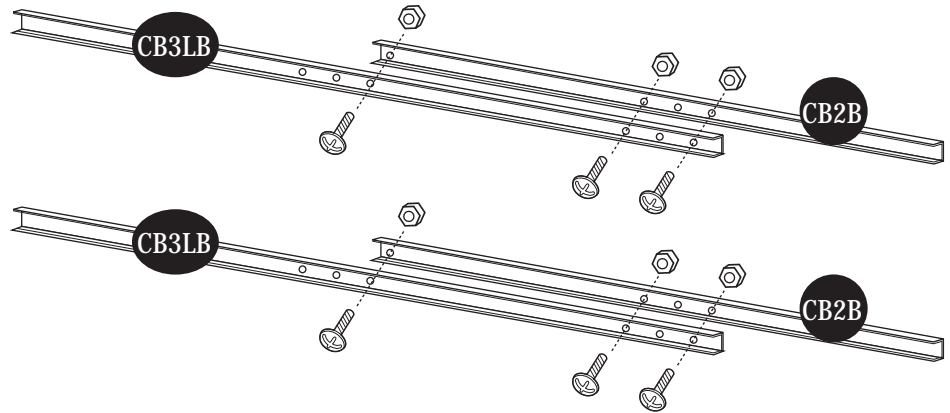

Fig.3: Fix the (EPS) at the end of (CB1B) & (CB4B).



7. Assemble the center bands (CB2B) & (CB3LB) with (S3) screws with nuts. Make 2 sets. Add one (CB3LB) for each extension.



8. Assemble the center bands (CB3LB) & (CB3SB) with (S3) screws with nuts. Follow Overlapping Method shown below.

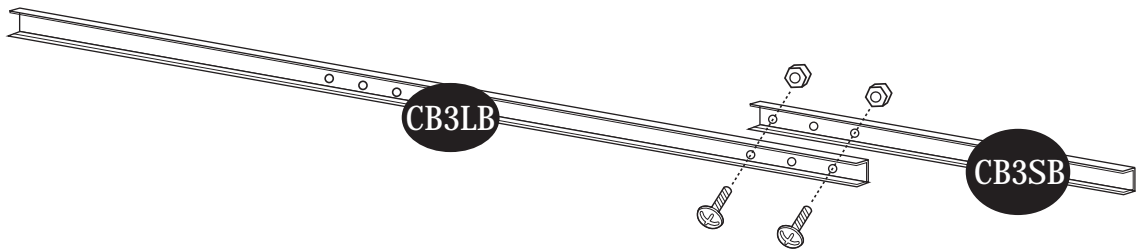

Overlapping Method

For Center Band, Roof structure (RS3B) & (RS3SB).

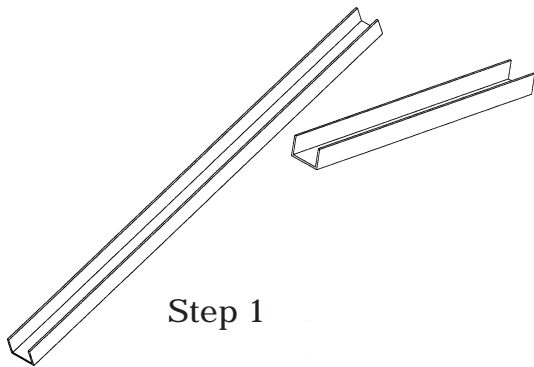

Step 1

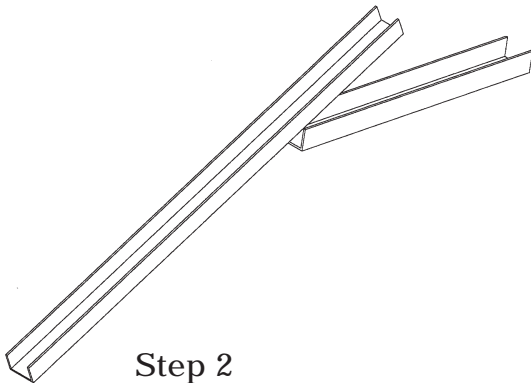

Step 2



Use a hammer to align the holes.

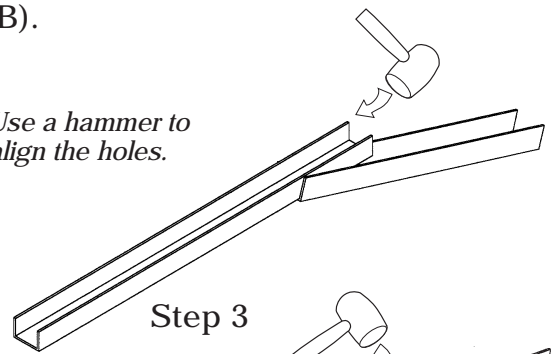

Step 3

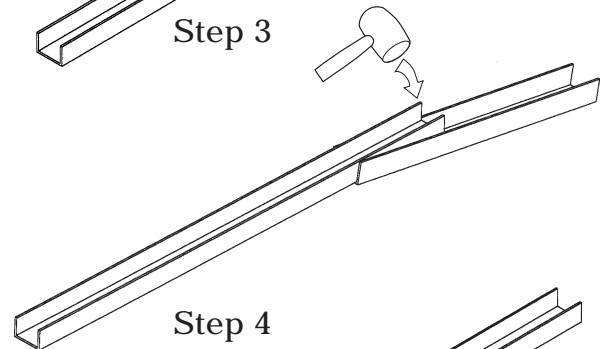

Step 4

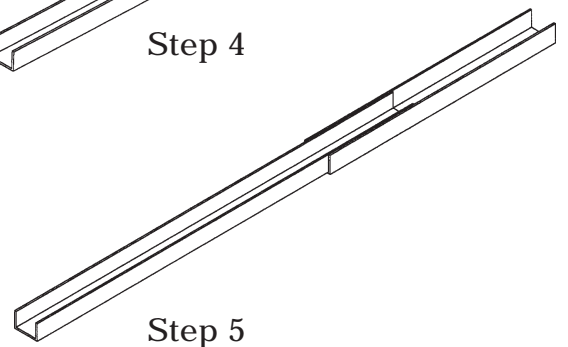

Step 5

9. Working from inside Continue connecting the side panels (SP↑) and columns (CMB) in sequence along (B2B) & (EXTR) base. Use (S1) screws to fix columns to base.

9a. For each extension add one side panel (SP↑) and one middle column (CMB) in extension base U-channel (EXTR) & (EXTL).

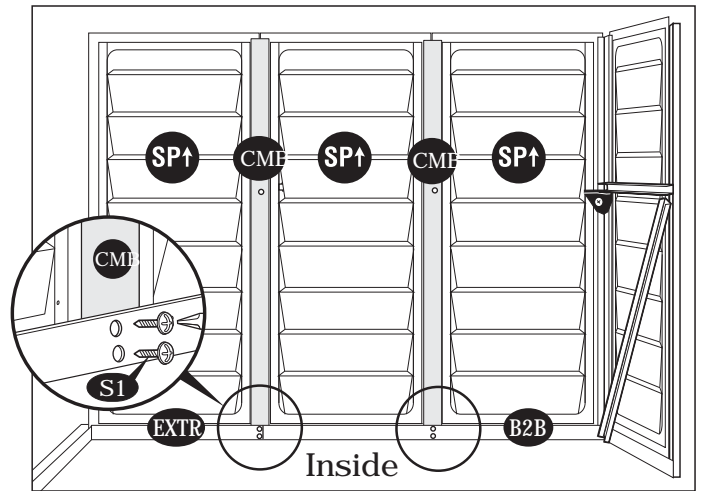

10. Slide corner column (CCB) into side panel (SP↑) pushing the column to the side panel.

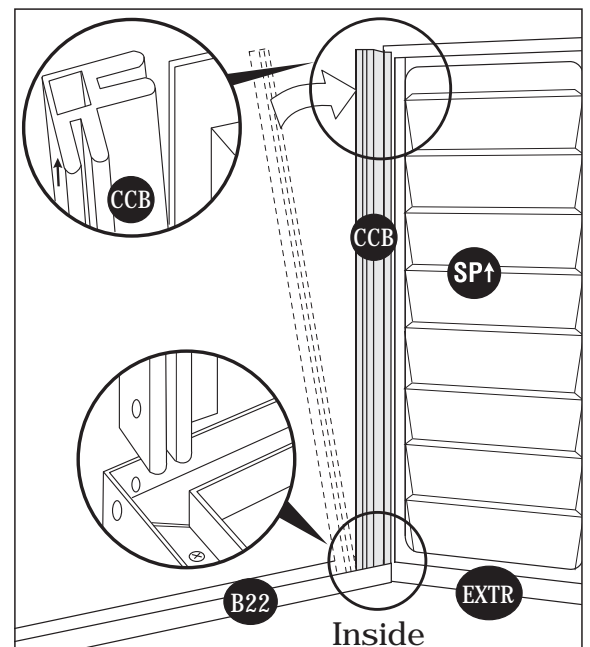

11. Working from outside use (S1) screws to secure column to bases (B22) and (EXTR).

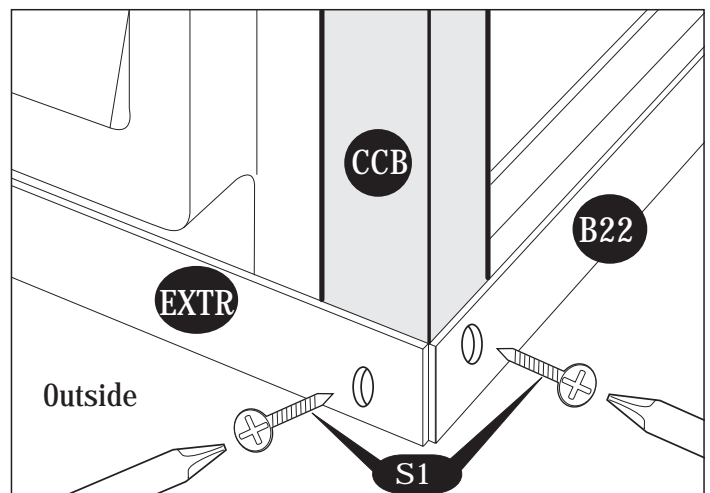

12. Stabilize the side panels with center bands (CB3LB) & (CB2B). Fix (FCB) fitting to corner column (CCB). See Fig.1 Follow the Fig. 2, 3, 4 & 5.

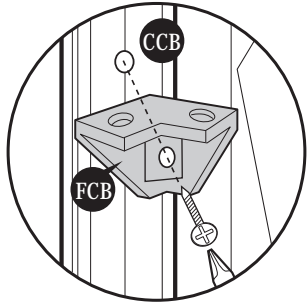
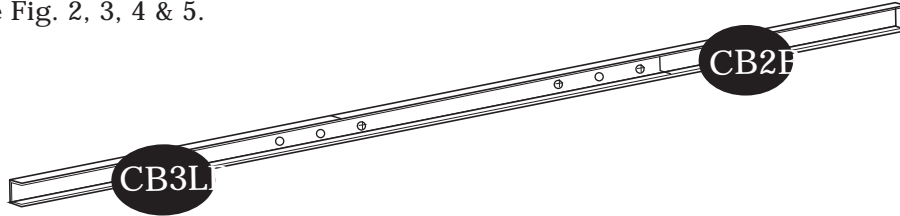

Fig.1: Use (S2) screws. Fix (FCB) fitting to (CCB). Leave it loose.

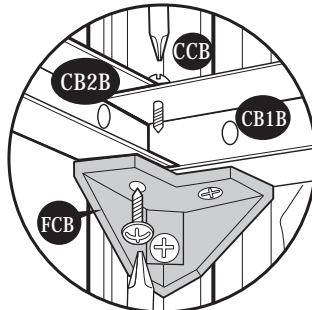

Fig.2: Use (S1) screws. Fix (CB2B) to (FCB) and (CB1B)

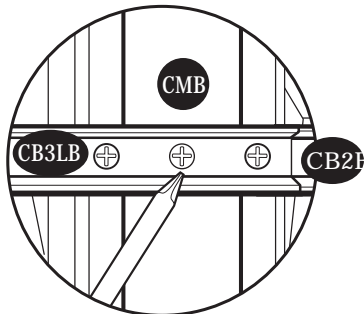
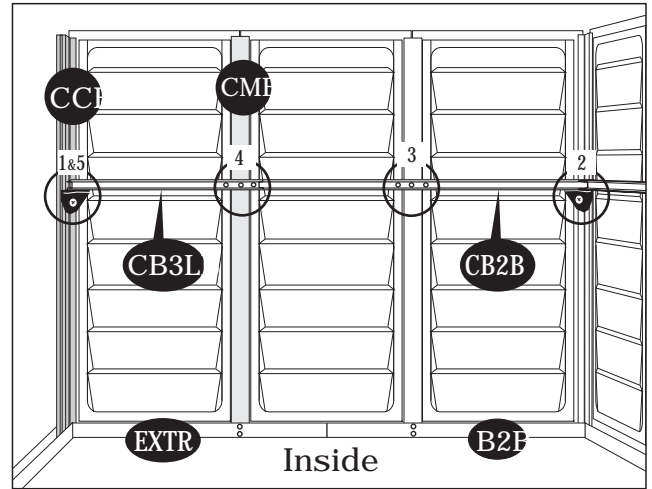

Fig.3: Fix to (CMB) with (S1) screw.

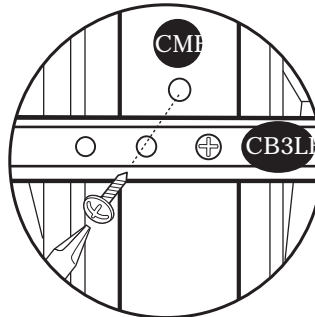

Fig.4: Use (S1) screws. Fix (CB3LB) to (CMB) columns.

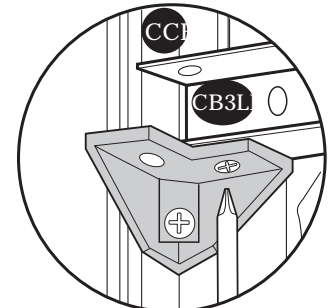
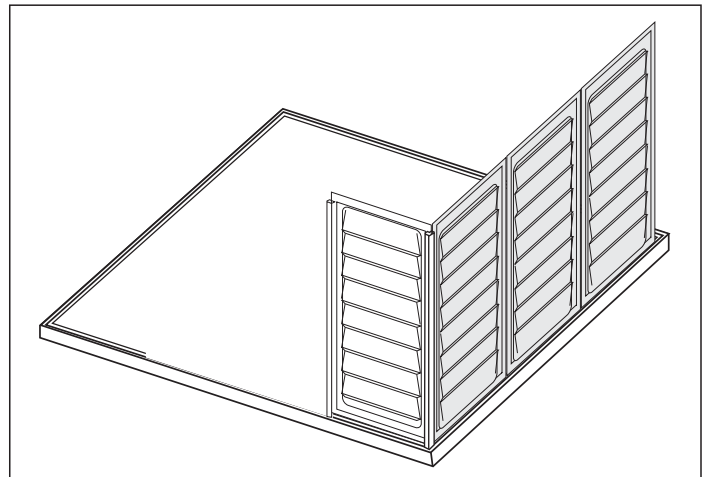
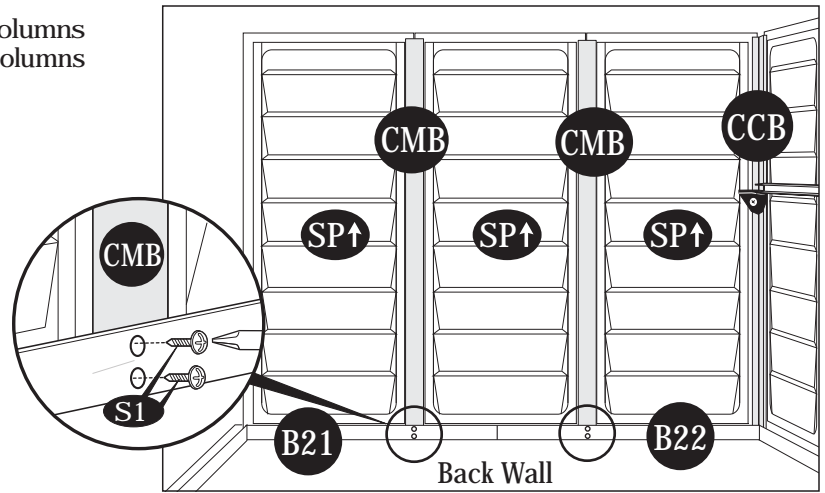

Fig.5: Use (S1) Screws. Fix (CB3LB) to (FCB) fitting.



13. Continue connecting the back panels and columns in sequence along base (B22) and (B21). Fix columns to base with (S1) screws.



14. Fix corner column (CCB) to last panel and base.

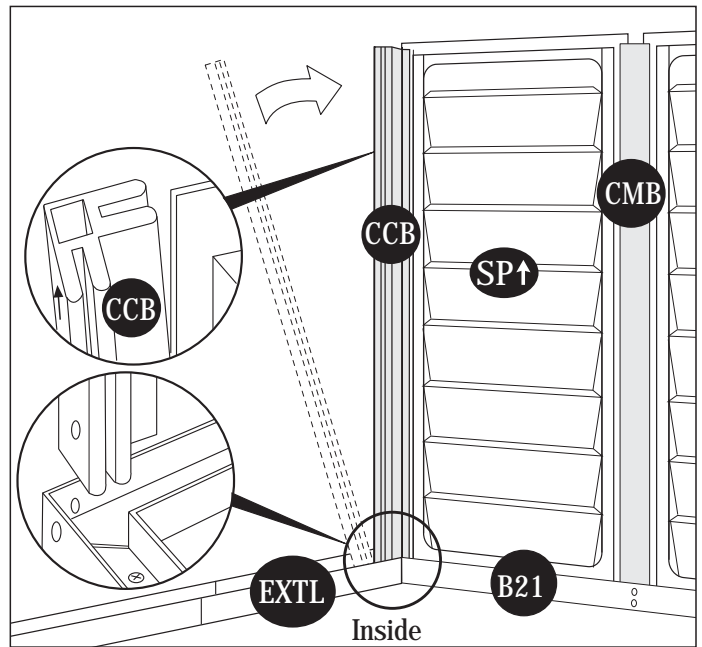

15. Working from outside use (S1) screws to secure the corner column (CCB) to bases (B21) and (EXTL).

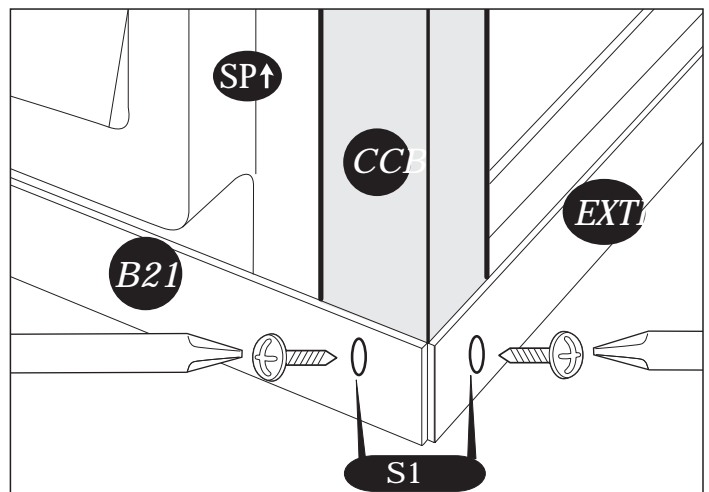

16. Stabilize Side panels with center bands (CB3SB & CB3LB). Fix (FCB) fitting to corner column (CCB) see figure 1. Follow figures 2,3 ,4 and 5.

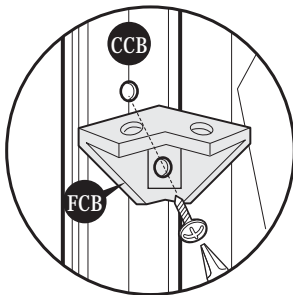
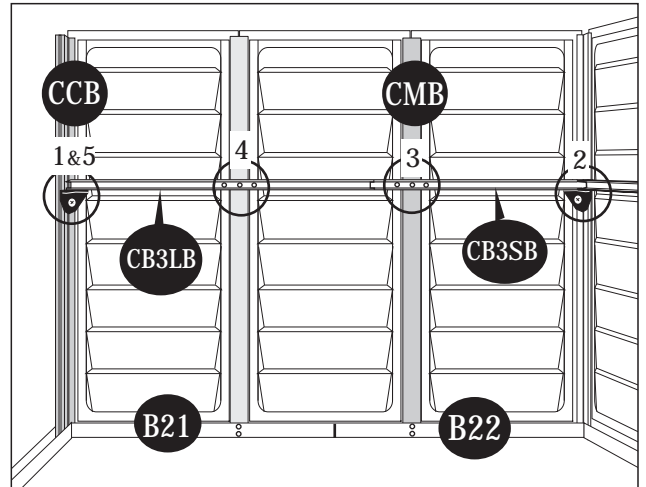
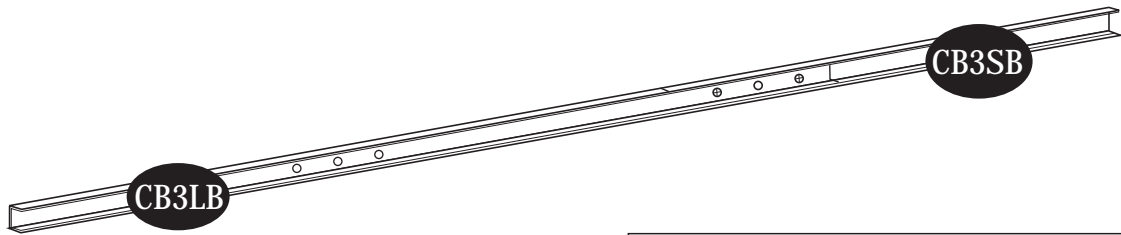

Fig.1: Use (S2) screws. Fix (FCB) to (CCB). Leave it loose.

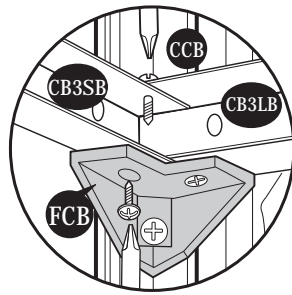

Fig.2: Use (S1) screws. Fix (CB3SB) to (FCB) and (CB3LB).

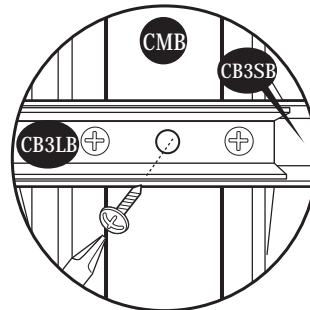

Fig.3: Fix to (CMB) with (S1) screws.

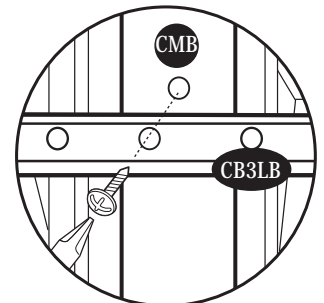

Fig.4: Fix to (CMB) with (S1) screws.

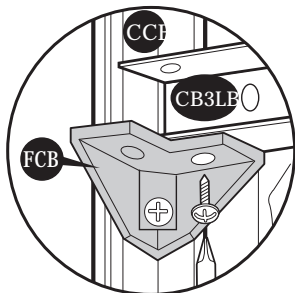
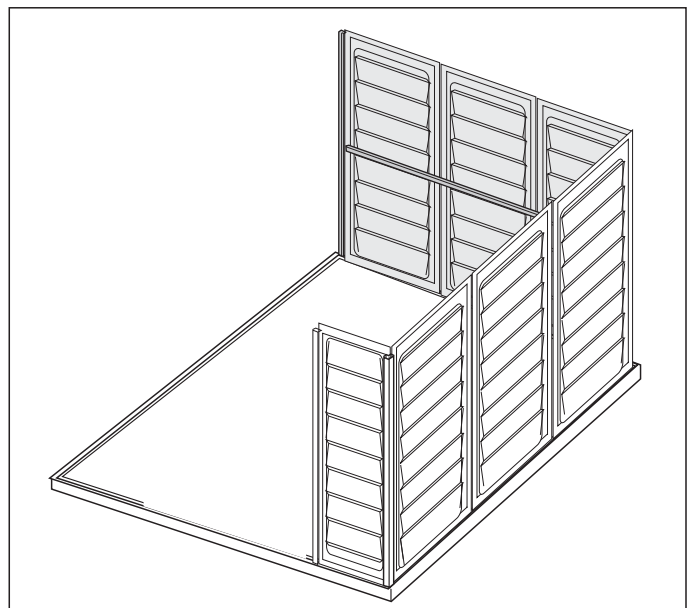
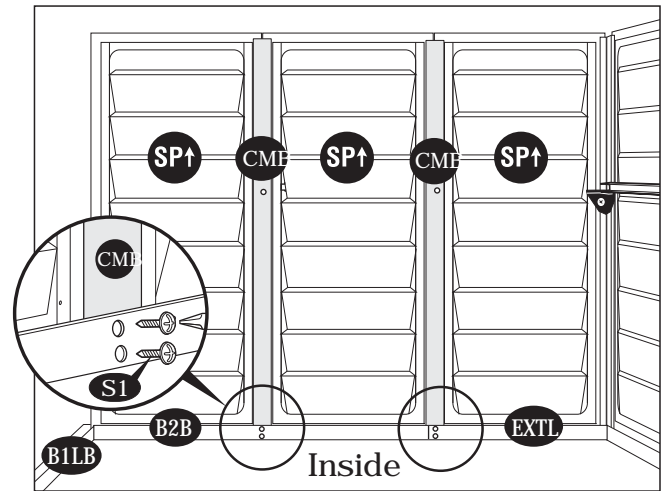

Fig.5: Use (S1) screws. Fix (CB3LB) to (FCB).



17. Working from inside Continue connecting the side panels (SP↑) and columns (CMB) in sequence along (B2B) & (EXTL) base. Use (S1) screws to fix columns to base.



18. Slide corner column (CCB) into side panel (SP↑) pushing the column to the side panel.

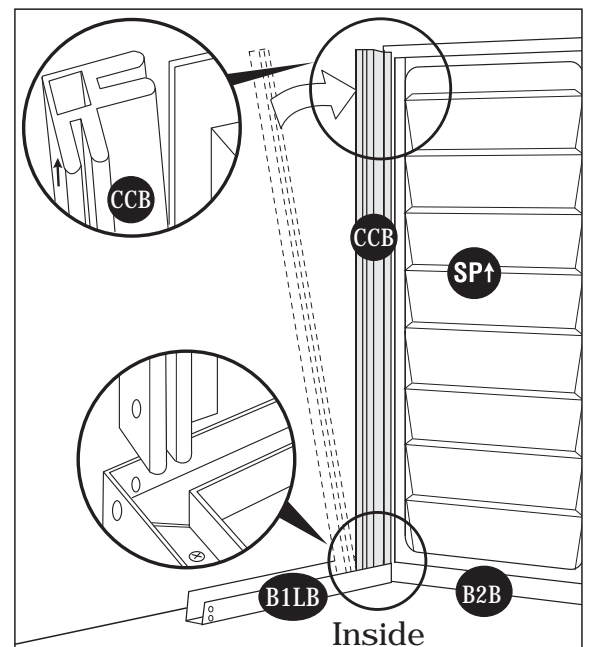

19. Working from outside use (S1) screws to secure column to bases (B2B) and (B1LB).

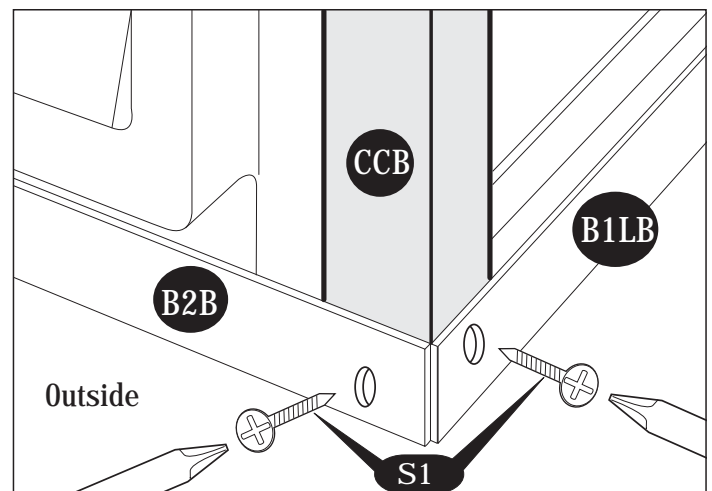

20. Stabilize the side panels with center bands (CB3LB) & (CB2B). Fix (FCB) fitting to corner column (CCB). See Fig.1 Follow the Fig. 2, 3, 4 & 5.

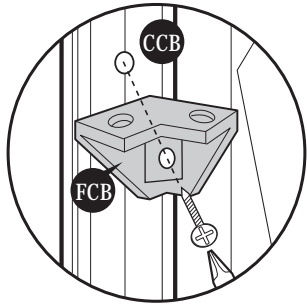
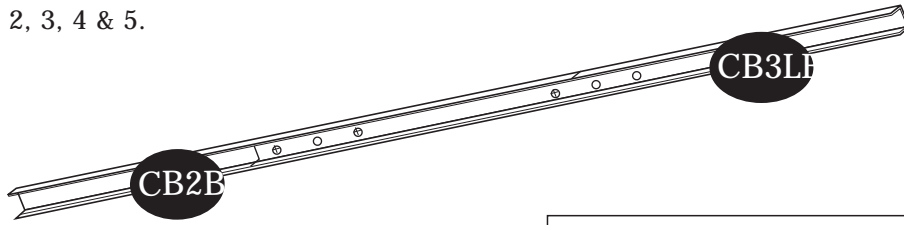

Fig.1: Use (S2) screws. Fix (FCB) fitting to (CCB). Leave it loose.

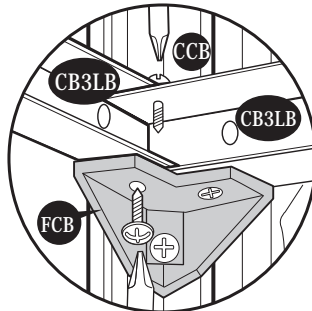

Fig.2: Use (S1) screws. Fix (CB3LB) to (FCB) and (CB3LB)

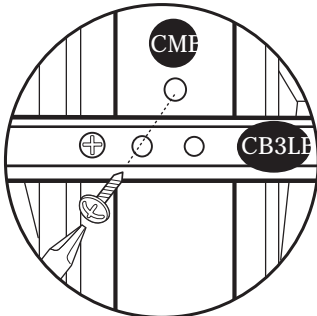
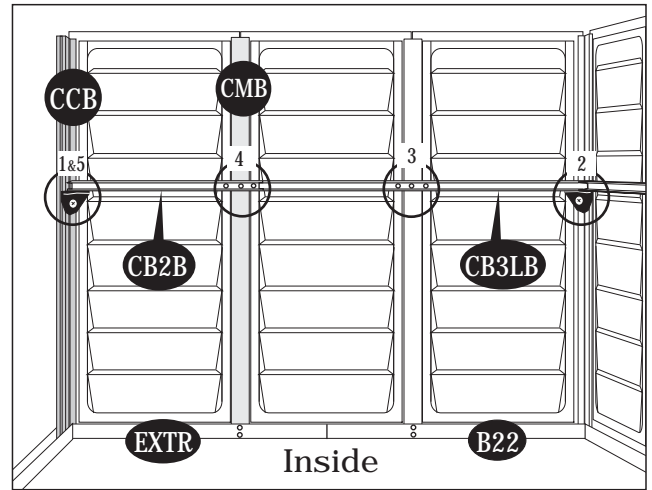

Fig.3: Use (S1) screws. Fix (CB3LB) to (CMB) columns.

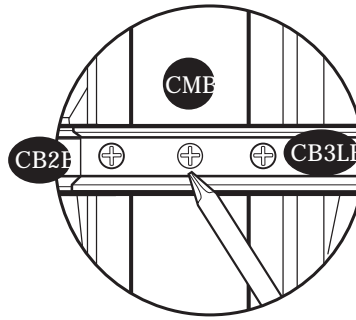

Fig.4: Fix to (CMB) with (S1) screw.

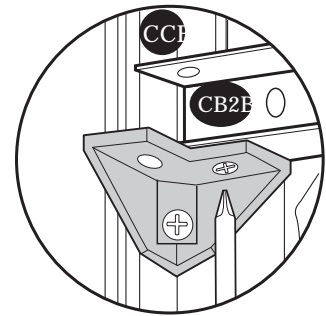
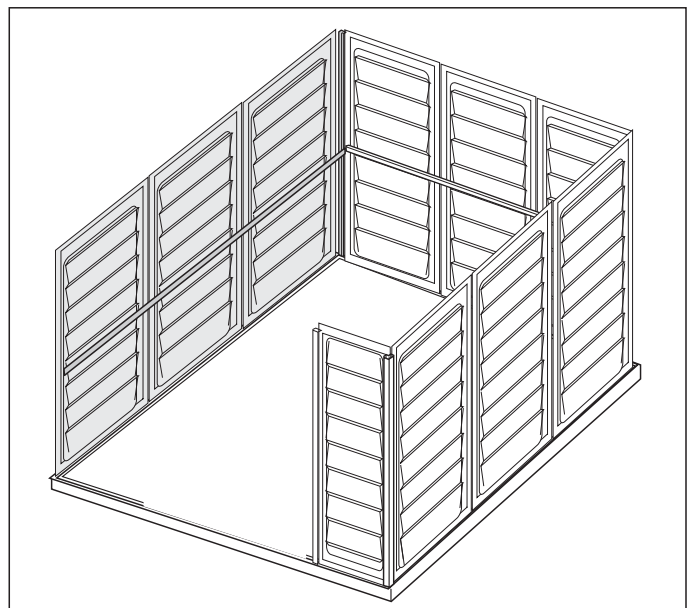
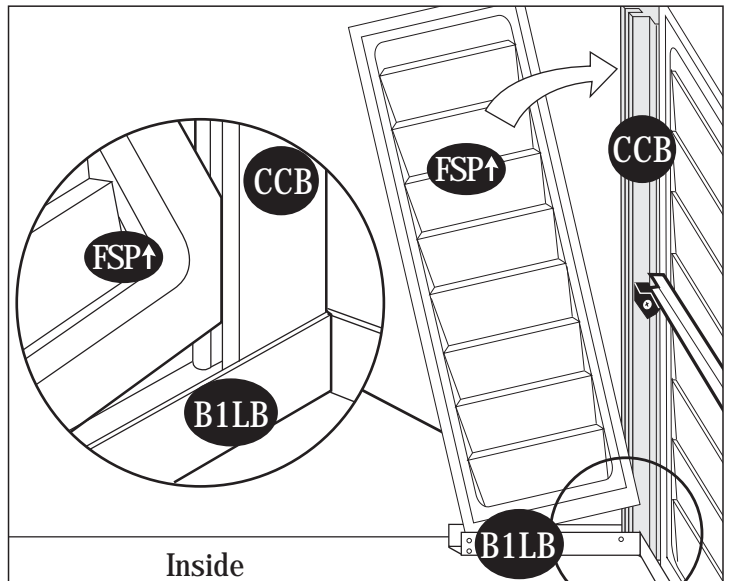

Fig.5: Use (S1) Screws. Fix (CB2B) to (FCB) fitting.



21. Insert the side panel (FSP↑) into the groove of column (CCB). Start at the bottom with panel at an angle then push into place.



22. Slide door column (CDLB) into the U-Channel Base (B1LB) on the left side of the door. Line up the pre-drilled holes on (CDLB) Column with pre-drilled holes on U-Channel Base (B1LB). Secure with two (S1) screws from inside. (see blowup detail).

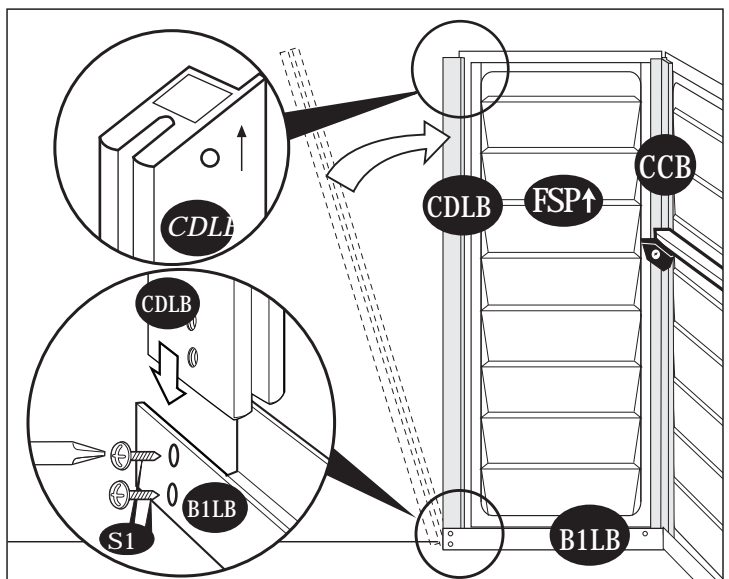

23. Attach the center band (CB1B) to door column, corner column and center band (CB2B). See figures 1 and 2.

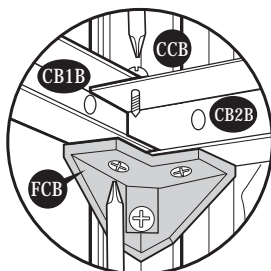

Fig.1: Use (S1) screws. Fix (CB1B) to (FCB) and (CB2B).

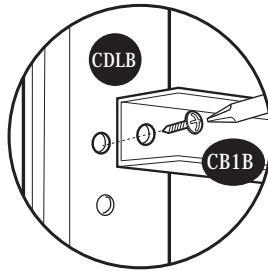
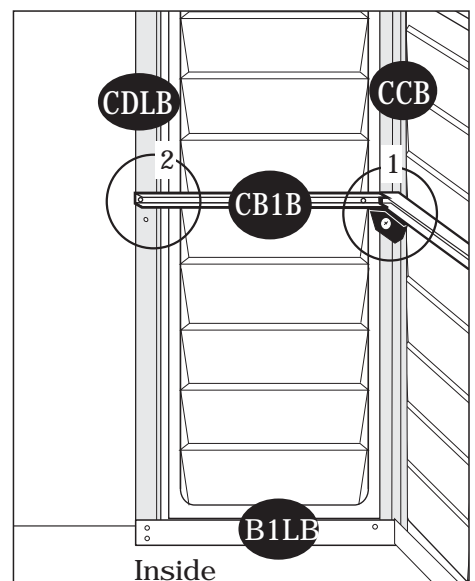

Fig.2: Use (S1) screw. Fix (CB1B) to (CDLB)



Note After completing the center band assembly fully tighten the four center band fittings (FCB) to the corner column (CCB).

24. Fix center band (CB4B) to (CDLB) and base (B1LB).
See Fig. 1, 2 and 3.

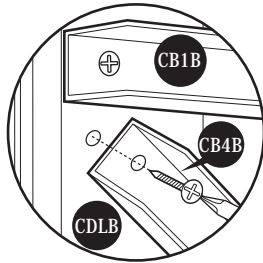

Fig. 1: Use (S1) screw. Fix (CB4B) to (CDLB)

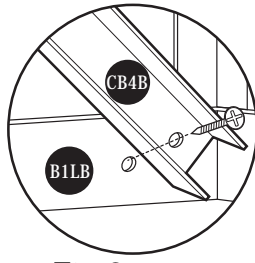

Fig. 2: Use (S1) screw. Fix (CB4B) to base (B1LB)

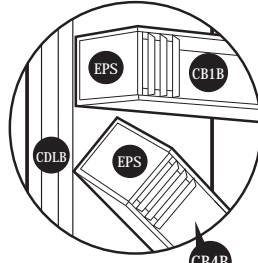
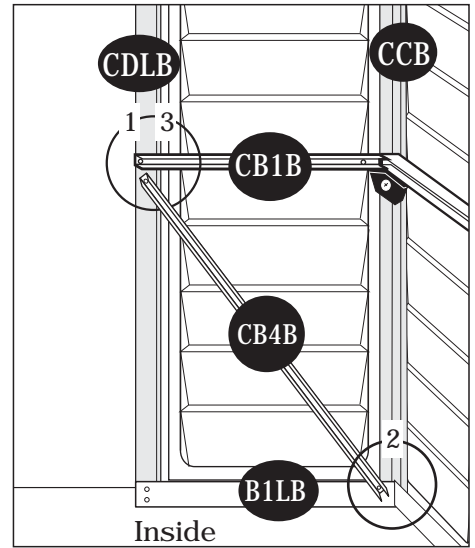
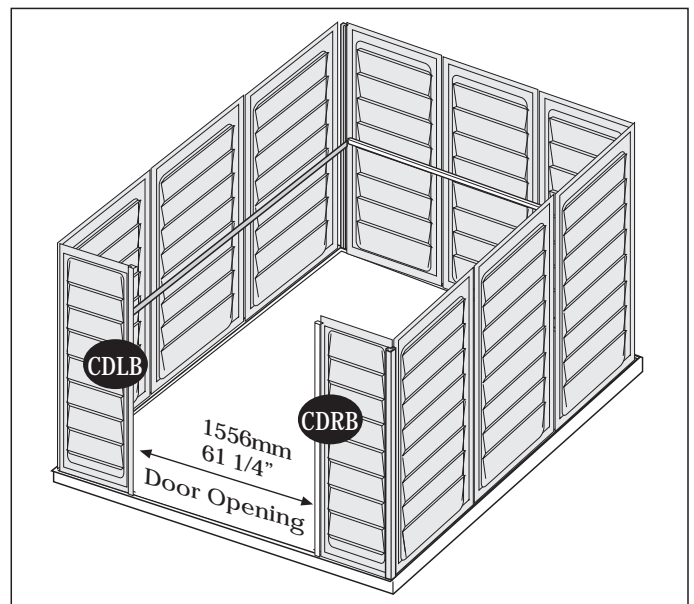

Fig. 3: Fix the (EPS) at the end of (CB1B) & (CB4B).



25. Make sure the door opening between the door columns (CDLB) and (CDRB) is 61 1/4" (1556mm). This will ensure a perfect fit for the doors.



C. Roof Frame



Parts Needed:

- | | |
|---------------------------------------|---------|
| (4) RS1 Roof Structure | (RS1B) |
| (4) RS2 Roof Structure | (RS2B) |
| (2) RS3 Roof Structure | (RS3B) |
| (2) RS4 Roof Structure | (RS4B) |
| (4) RS5 Roof Structure | (RS5B) |
| (4) RS8 Roof Structure Support | (RS8B) |
| (4) RS9 Roof Structure Support Short | (RS9B) |
| (2) RS10 Roof Structure Support | (RS10B) |
| (1) RS11 Roof Structure Support Short | (RS11B) |
| (1) Door Stopper Horizontal | (DSH) |
| (1) Door Column Fitting Left | (FDCL) |
| (1) Door Column Fitting Right | (FDCR) |
| (4) Corner Column Fitting | (FCC) |
| (4) Middle Column Fitting | (FMC) |
| (4) 90 Degree Joint | (RJ) |

Parts Needed For Each Extension:

- | | |
|---------------------------------------|---------|
| (2) RS3 Roof Structure Short | (RS3SB) |
| (2) RS4 Roof Structure | (RS4B) |
| (2) RS6 Roof Structure | (RS6B) |
| (2) RS7 Roof Structure | (RS7B) |
| (1) RS11 Roof Structure Support Short | (RS11B) |
| (2) Middle Column Fitting | (FMC) |

1. Insert the middle column fitting (FMC) into top of middle columns (CMB) square tubing inserts. Fix the column fittings (FMC) to columns (CMB) with (S1) screws.

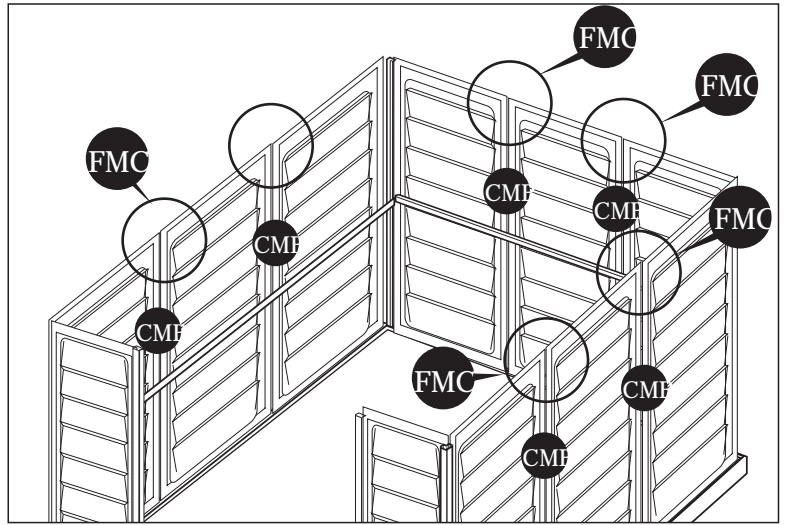
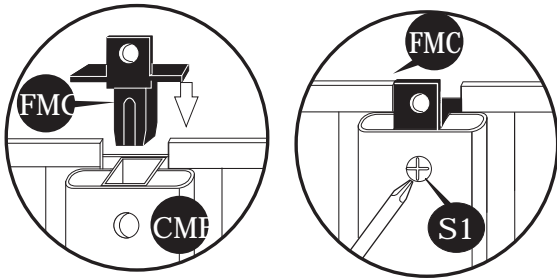

2. Insert the corner column fittings (FCC) into the corner column's (CCB) insert square tubing. Fix (FCC) to (CCB) with (S1) screws.

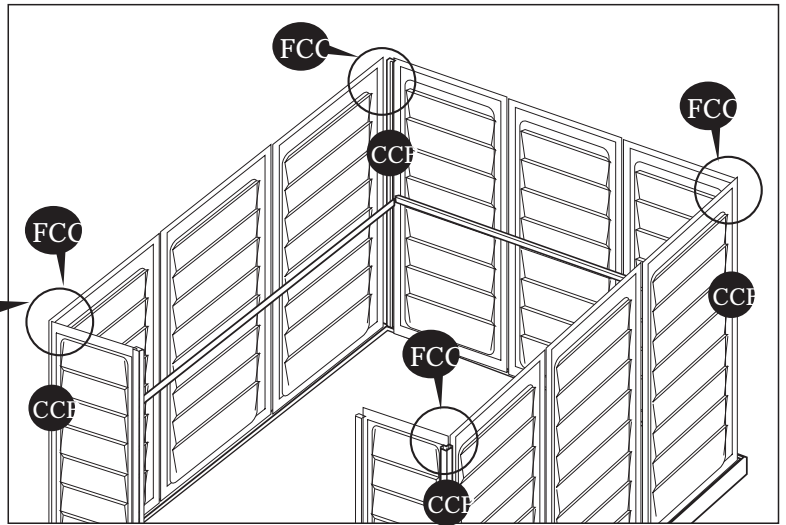
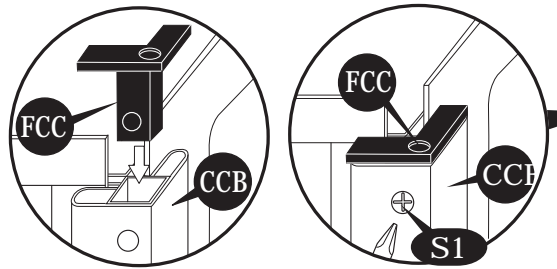

3. Insert the door column fittings (FDCL) and (FDCR) left and right into the door columns (CDLB) and (CDRB) square tubing inserts. Fix with (S1) screw.

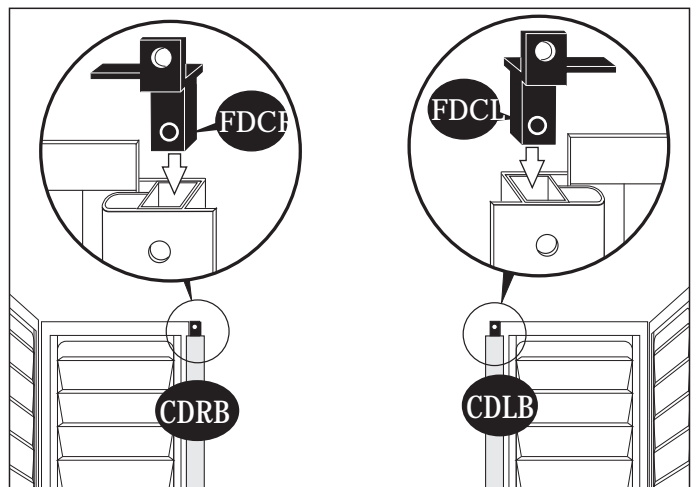

8' x 6' ROOF STRUCTURE EXPLODED VIEW

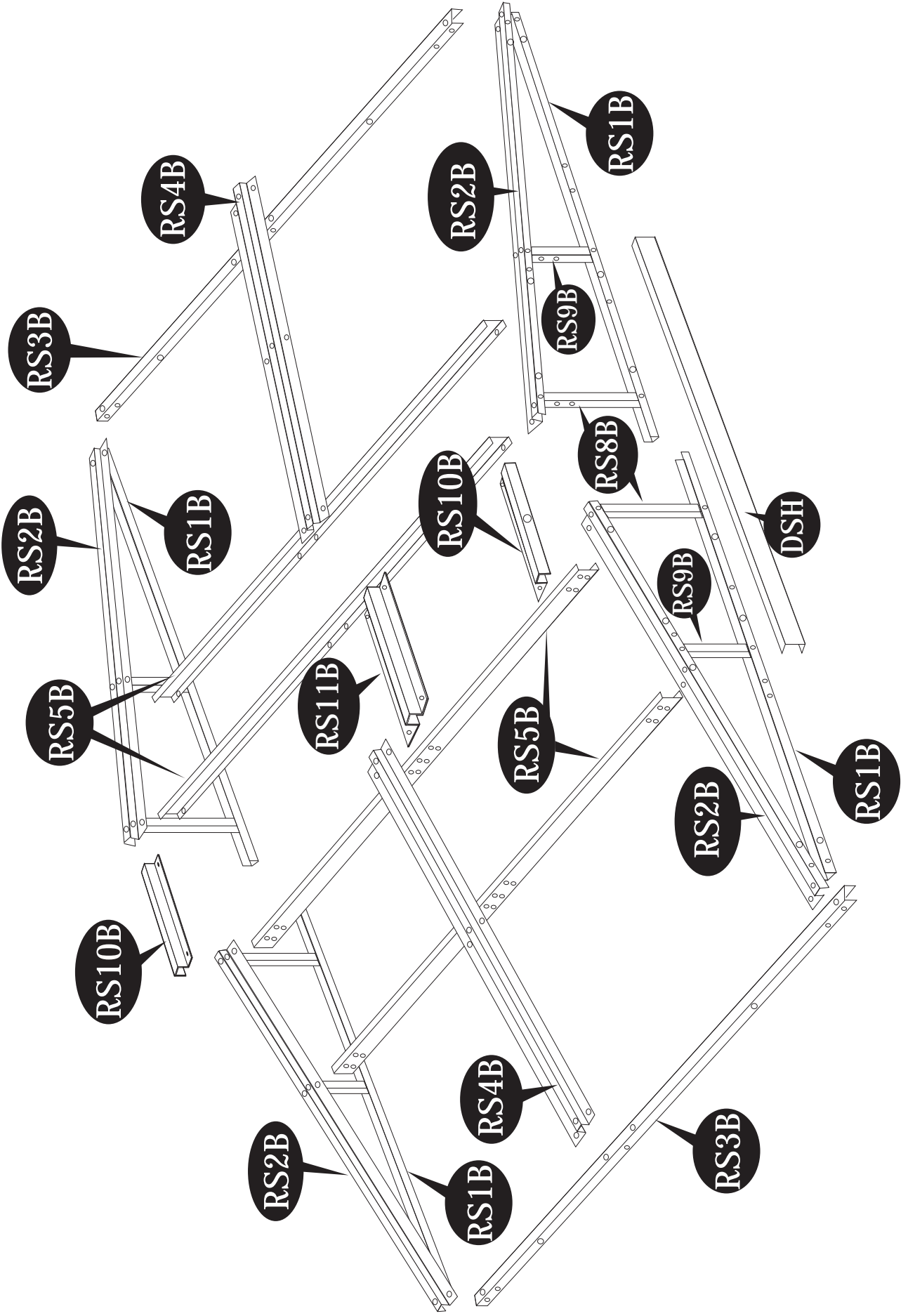

ROOF STRUCTURE EXPLODED VIEW WITH ONE EXTENSION

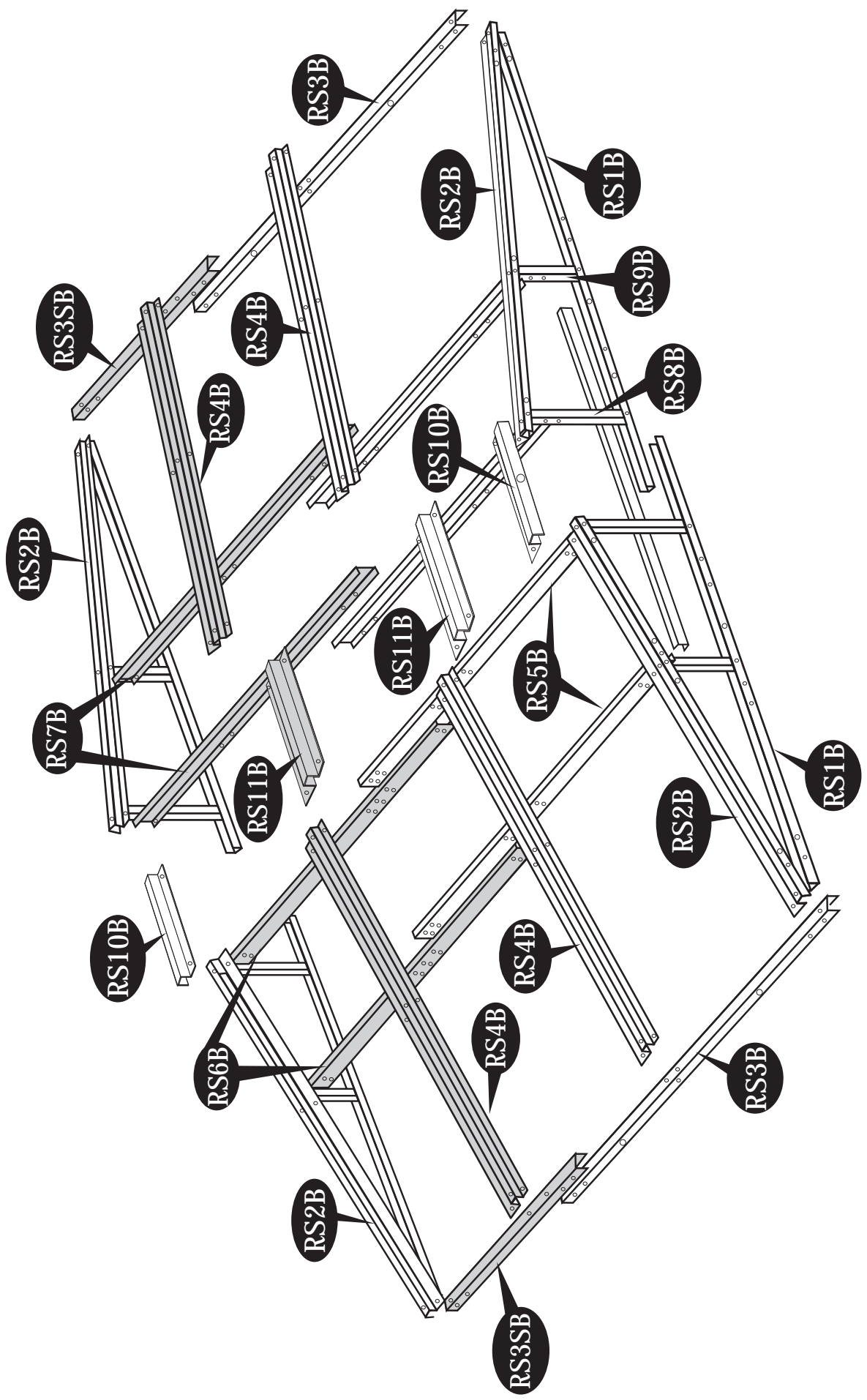

Front roof structure assembly

4. Assemble front roof structure (RS1B) and (RS1B) with 2 (S3) screws with nuts.

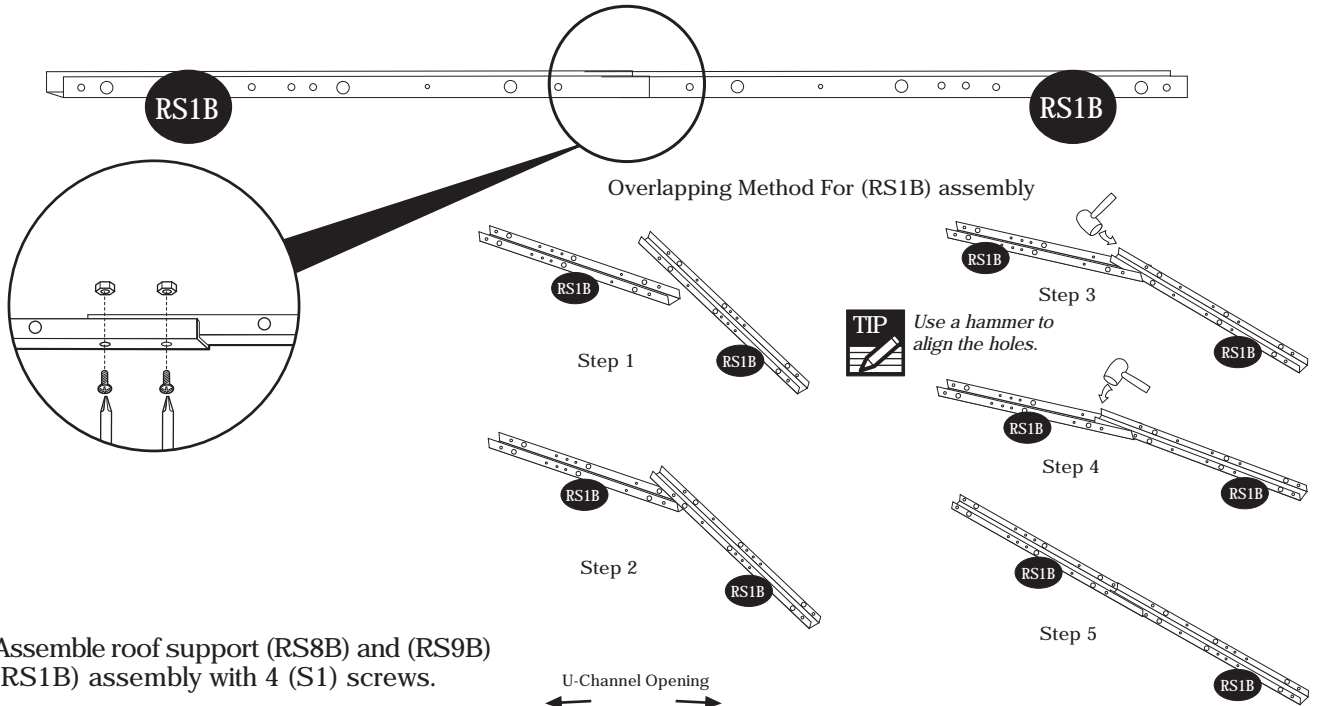

5. Assemble roof support (RS8B) and (RS9B) to (RS1B) assembly with 4 (S1) screws.

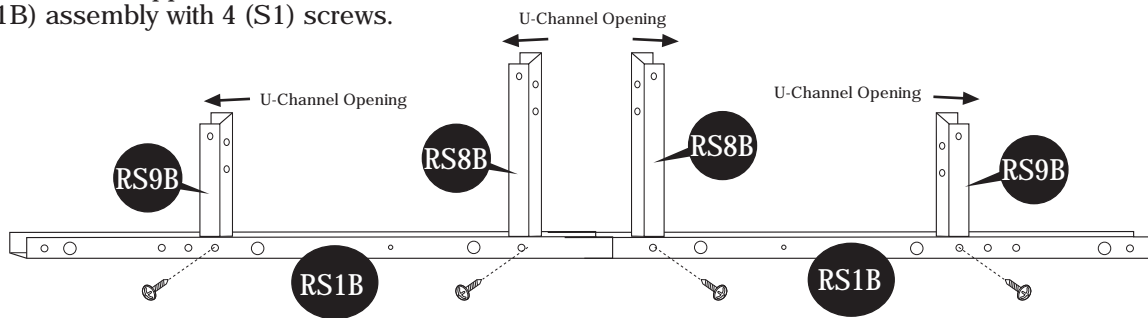

6. Assemble roof structure (RS2B) to (RS8B) and (RS9B) with (S1) screws.

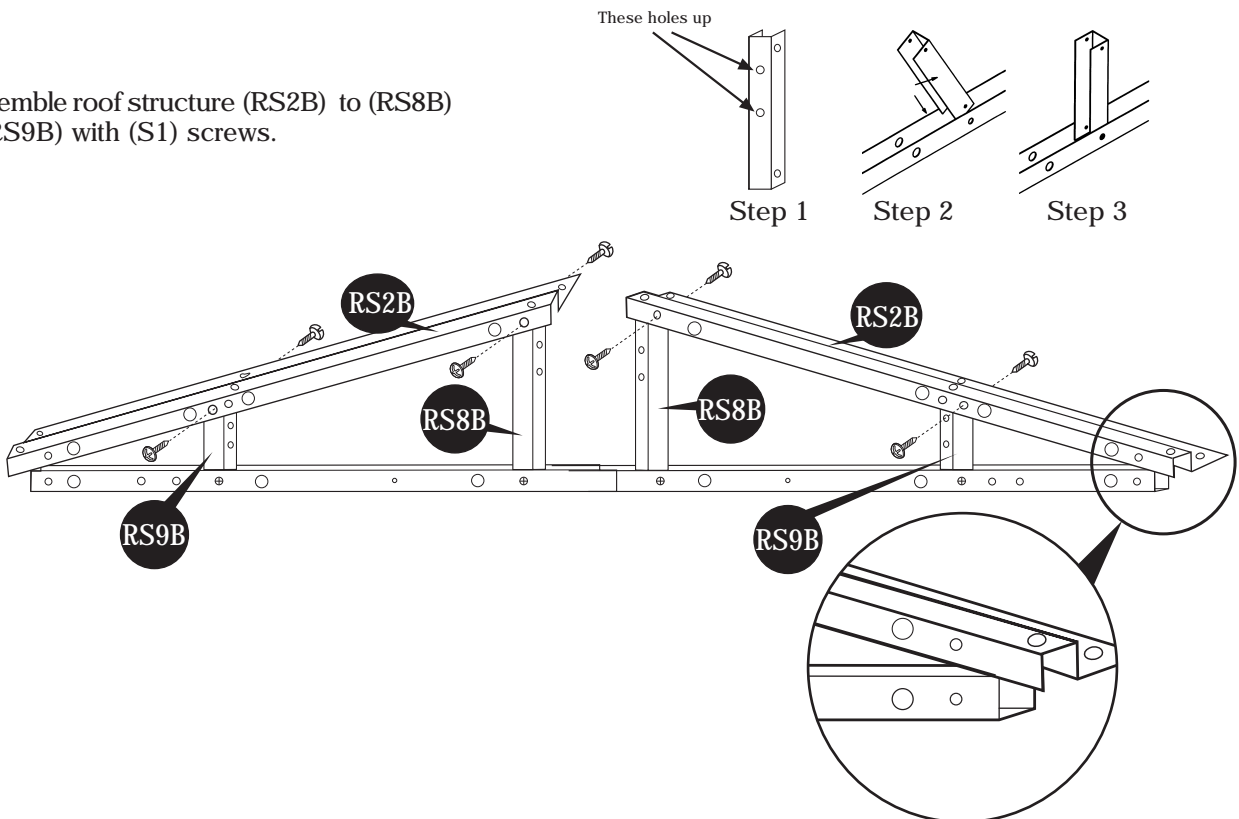

Back roof structure assembly

7. Assemble back roof structure (RS1B) and (RS1B) with 2 (S3) screws with nuts.

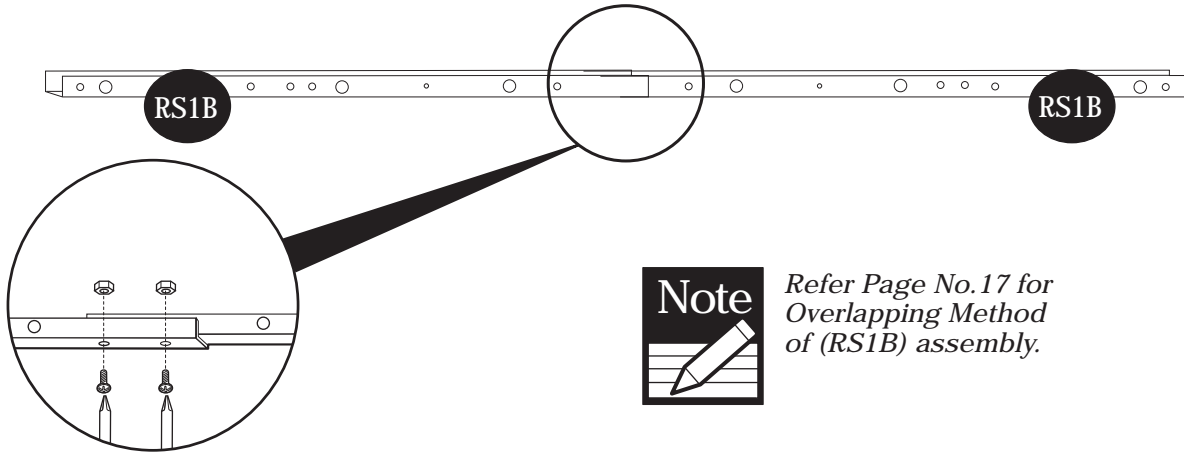

8. Assemble roof support (RS8B) and (RS9B) to (RS1B) assembly with 8 (S1) screws.

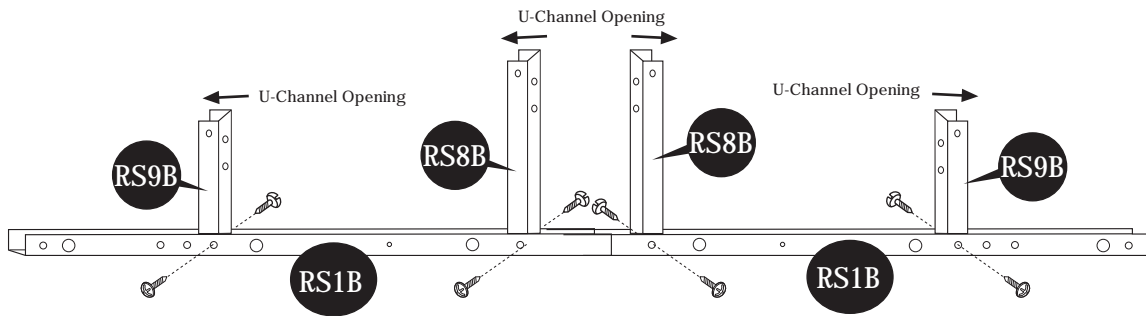

9. Assemble roof structure (RS2B) to (RS8B) and (RS9B) with (S1) screws.

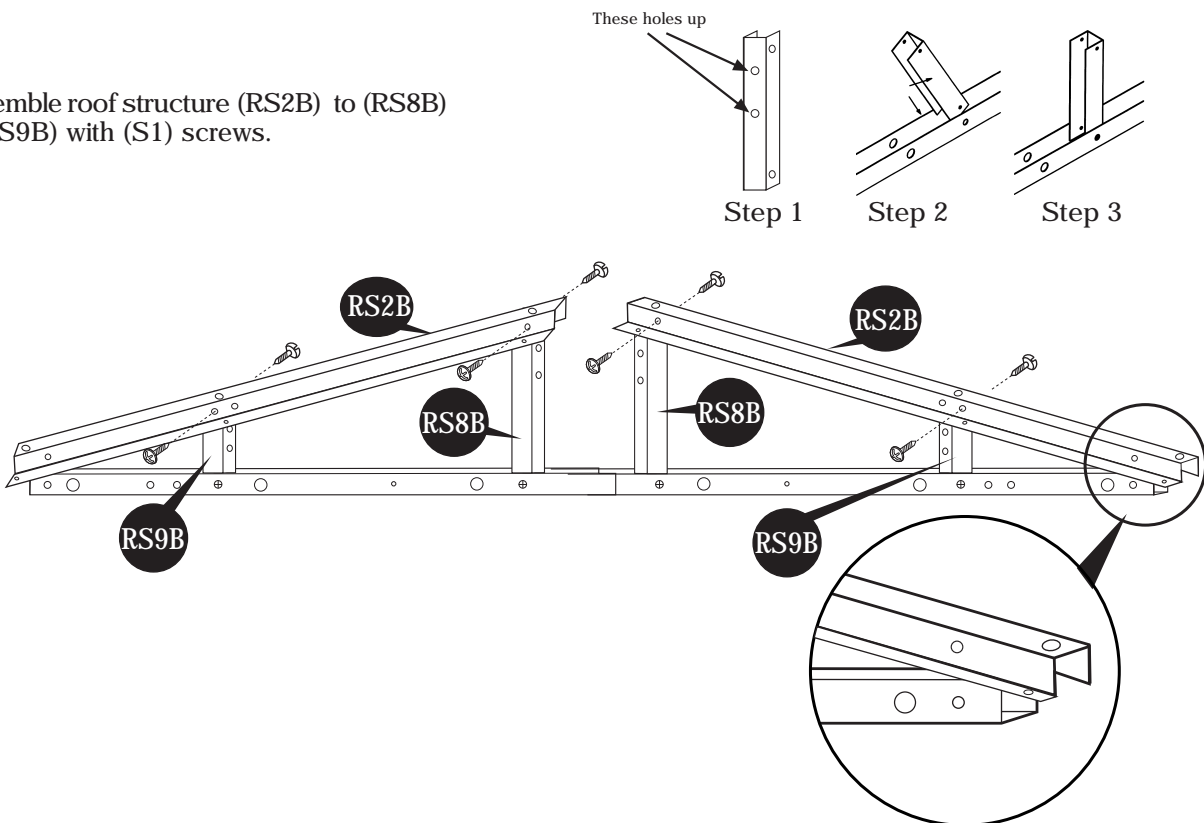

10. Assemble (RS3B) & (RS3SB) with (S1) screws (2 sets).
See fig 1.

10a. Insert 90 degree joint (RJ) into the (RS3B) U-channel Roof support. Use a hammer to push in. Use (S1) screws to fix. Repeat on other end of (RS3SB).
See fig.2 and fig.3.
Add one (RS3SB) for each extension.

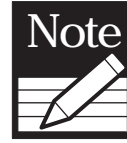
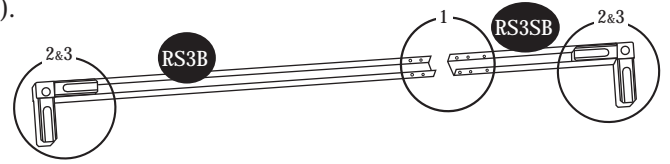

Refer Page No.5 for Overlapping Method of (RS3B) & (RS3SB).

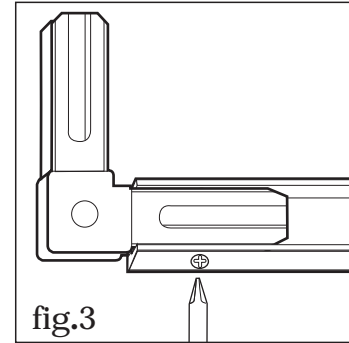
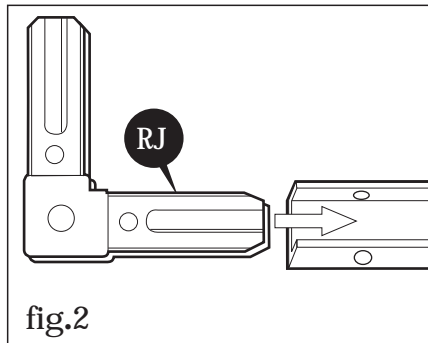
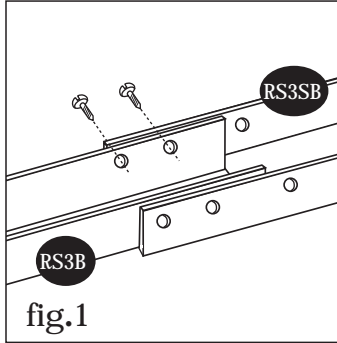

11. Assemble the roof structure (RS5B) into (RS6B) with 6 (S3) screws with nuts (2 sets).
Add one (RS6B) for each extension.

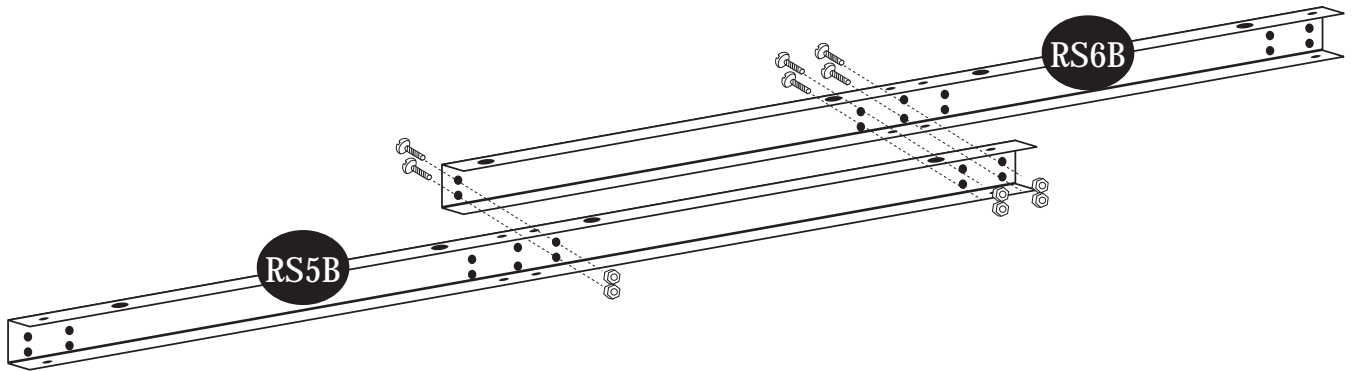

12. Assemble the roof structure (RS5B) into (RS7B) with 6 (S3) screws with nuts (2 sets).
Add one (RS7B) for each extension.

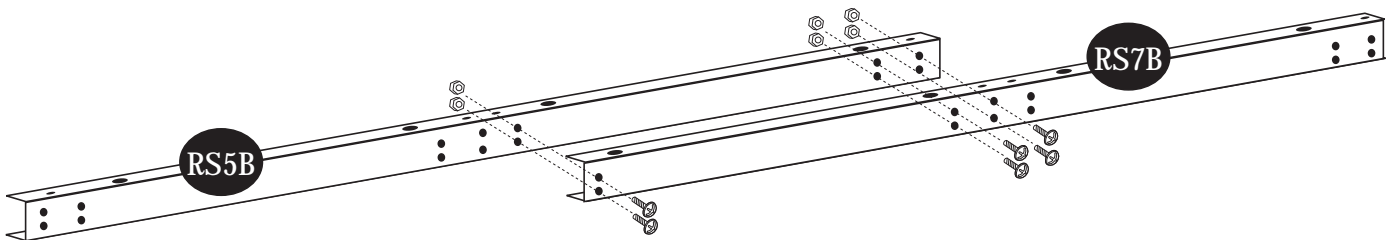

13. Lift the assembled front roof structure into position on top of door columns. Line up pre-drilled holes with door column fittings (FDCL) & (FDCR). Use (S1) screws to fix front roof structure to the door columns with left and right door fittings.

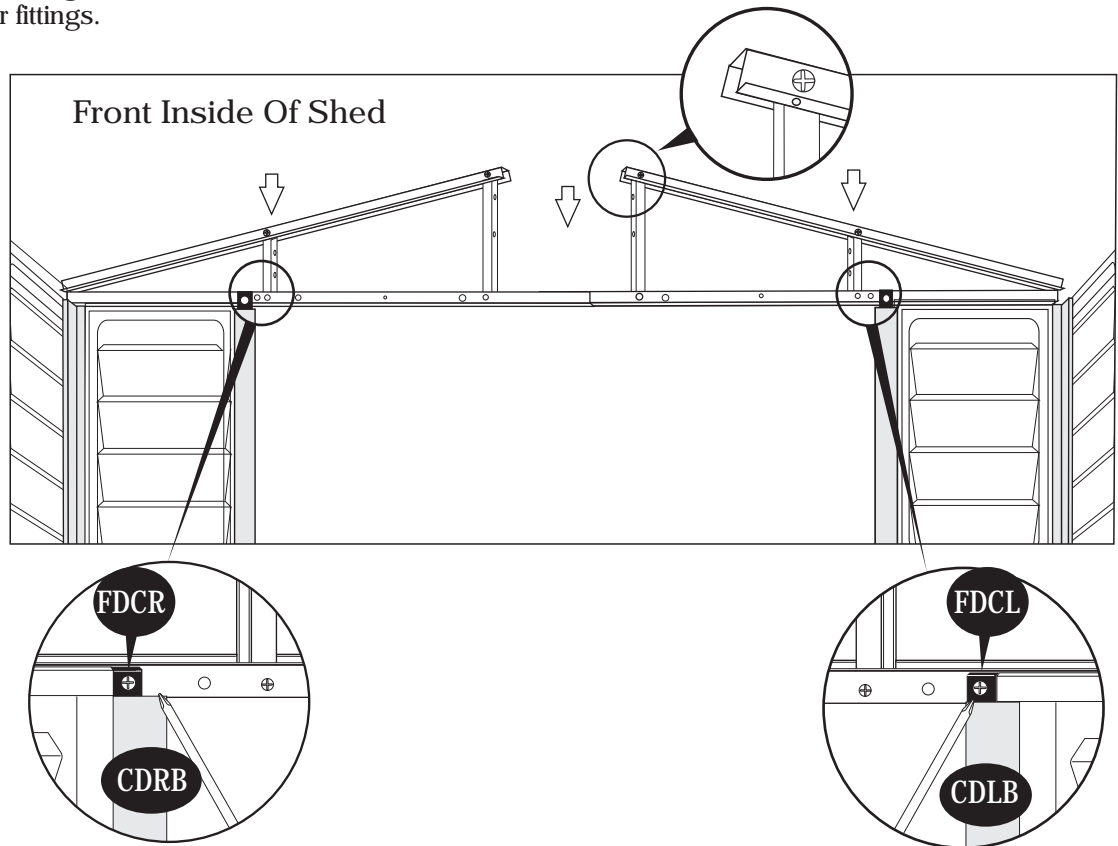

14. Fix the door stopper horizontal (DSH) to the front roof structure from inside with 8 (S1) screws. Position the latch hole to face down.

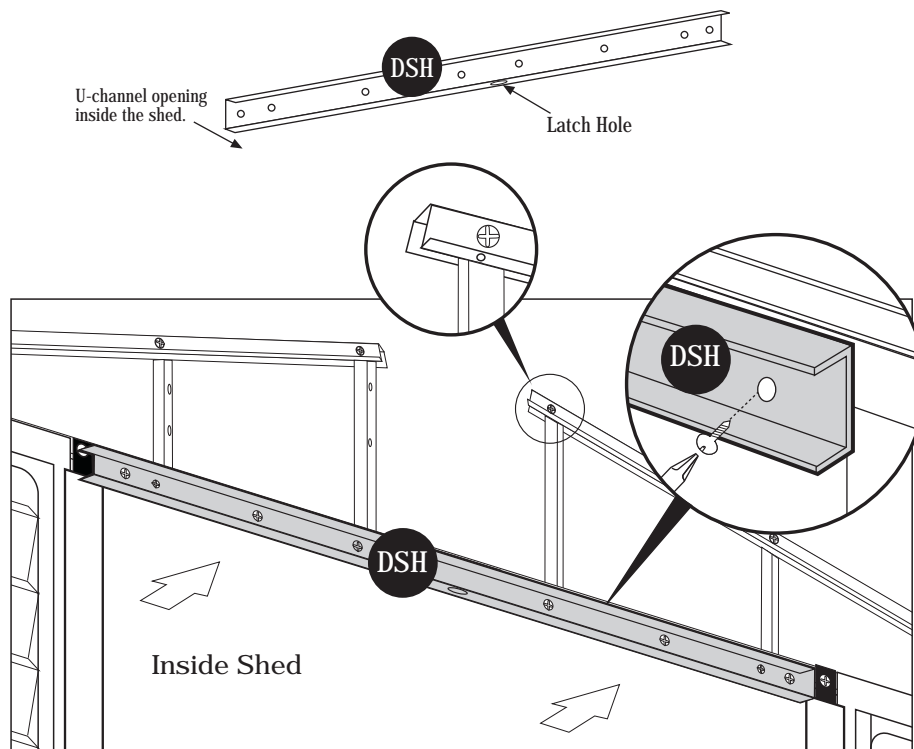

15. Lift the assembled back roof structure into position on top of columns (CMB). Line up pre-drilled holes with column fittings (FMC). Use (S1) screws to fix back roof structure to (FMC).

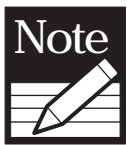
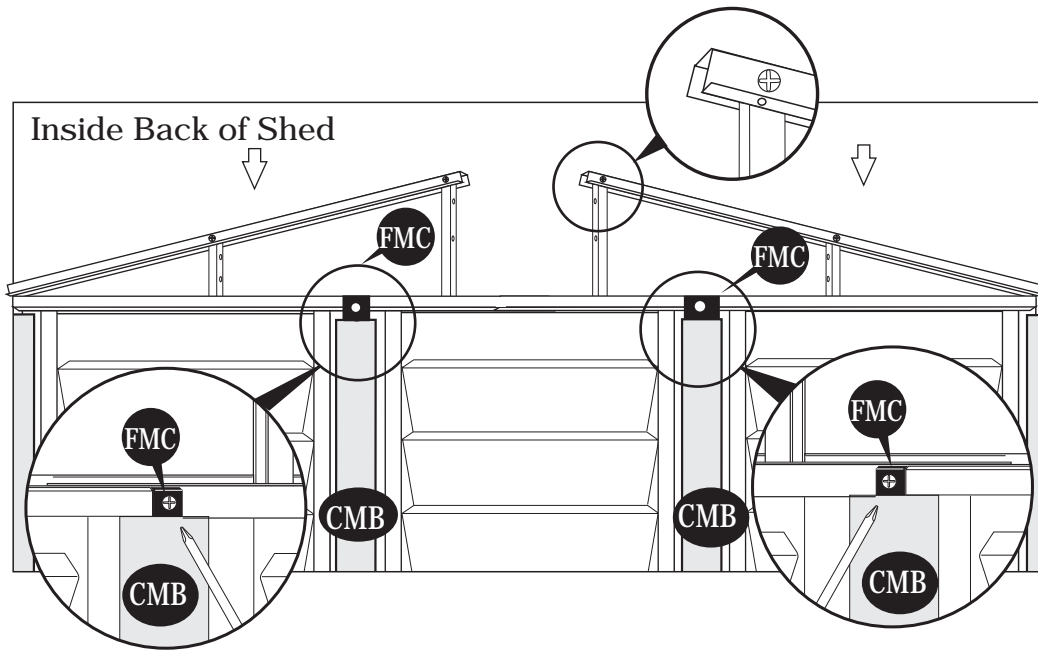

Note Make sure front and back assembly, the (RS2B) roof structure position towards inside the shed as shown in Fig.1 & Fig.2

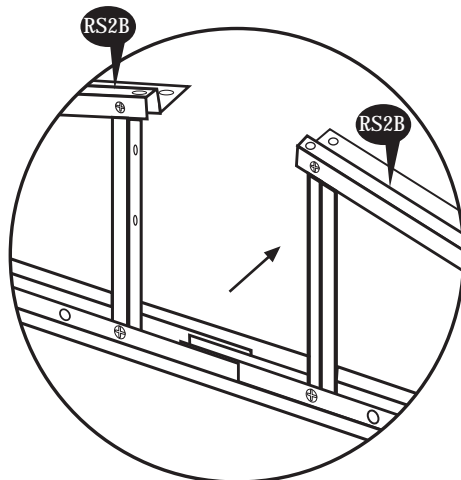
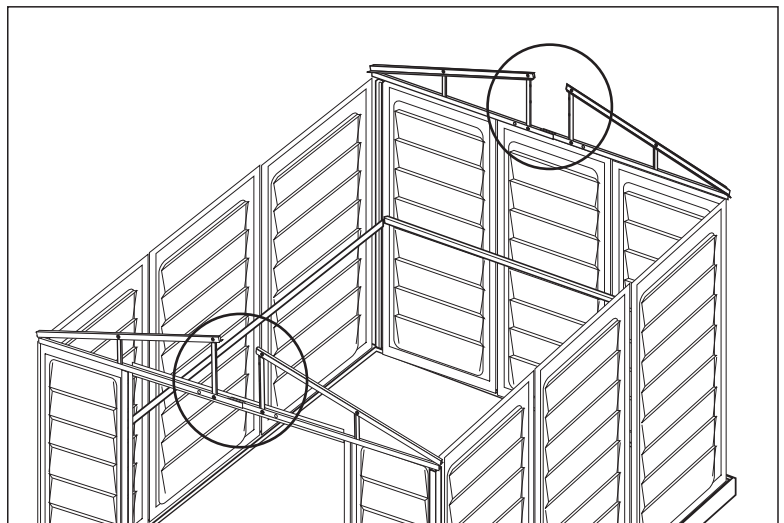

Fig. 1

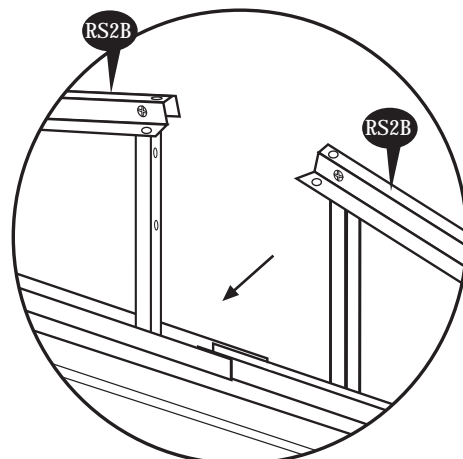
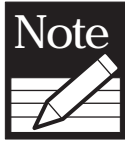
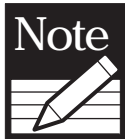
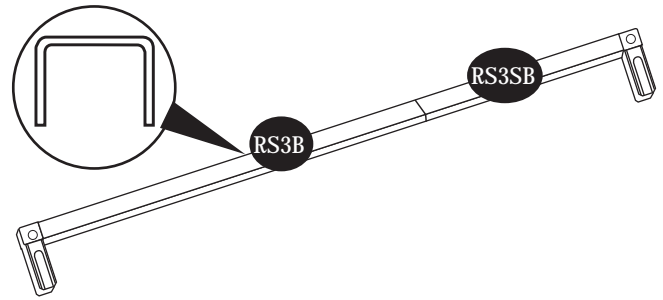

Fig. 2

16. Insert the roof supports (RS3B) & (RS3SB) assembly into the U-channel of roof structures (RS1B) . See (fig.1) Follow Fig. 2 and 3.



After assembly make sure this roof structure's U-Channel is positioned down.



Notice the U-channel up position on roof structures (RS1B).

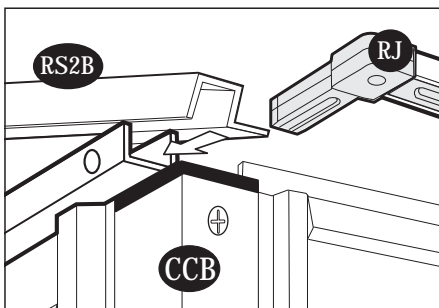
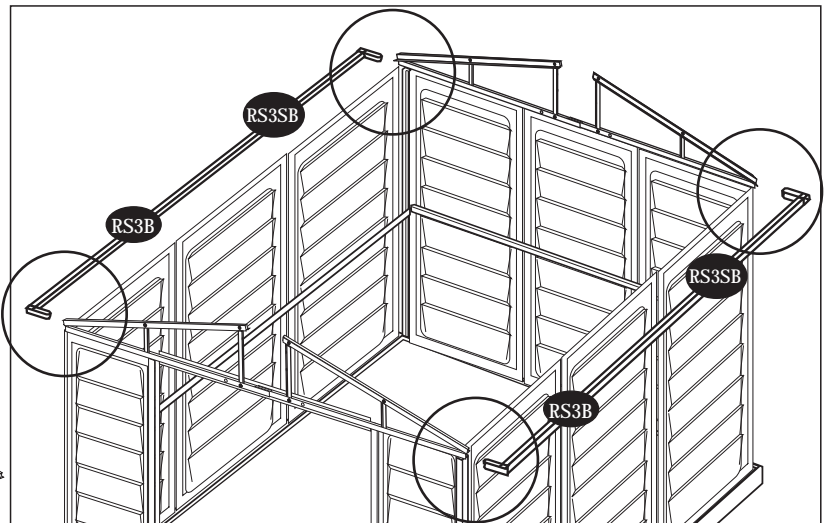
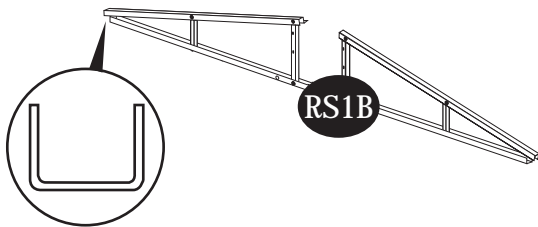

fig.1

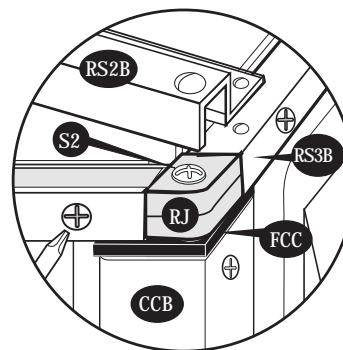

fig.2

Secure (RJ) 90 degree joint to (RS1B) with (S1) screws on top of the four corner joints (CCB).
Secure (RJ) with (FCC) using (S2) screw on all the four corner columns.

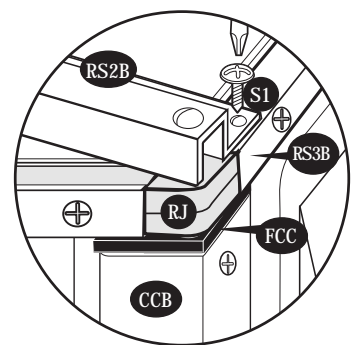
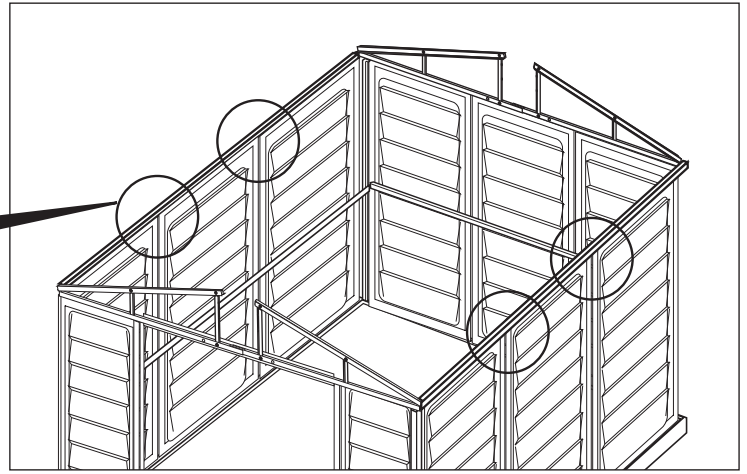
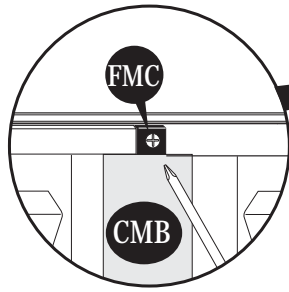

fig.3

Fix (RS2B) to 90 degree joint (RJ) through (RS3B) & (RS3SB) with (S1) screw.

17. Fix the (RS3B) & (RS3SB) to (FMC) middle column fitting with (S1) screws



18. Lift the assembled roof supports (RS5B) & (RS6B) into position on roof supports (RS8B) at the left side of the shed. Use (S1) screws to fix (RS5B) & (RS6B) to (RS8B); and (RS2B) to (RS5B) & (RS6B). See Fig.1 & Fig.2

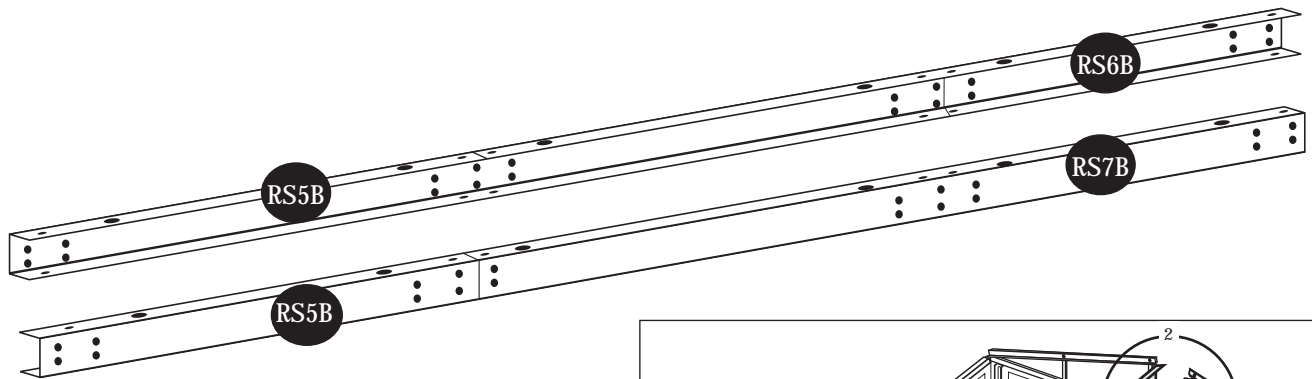

19. Lift the assembled roof supports (RS5B) & (RS7B) into position on roof supports (RS8B) at the right side of the shed. Use (S1) screws to fix (RS5B) & (RS7B) to (RS8B); and (RS2B) to (RS5B) & (RS7B). See Fig.1 & Fig.2

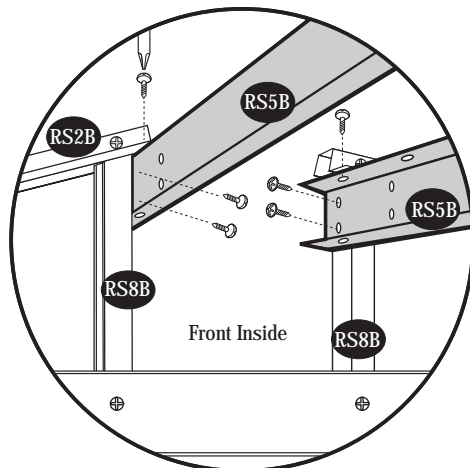
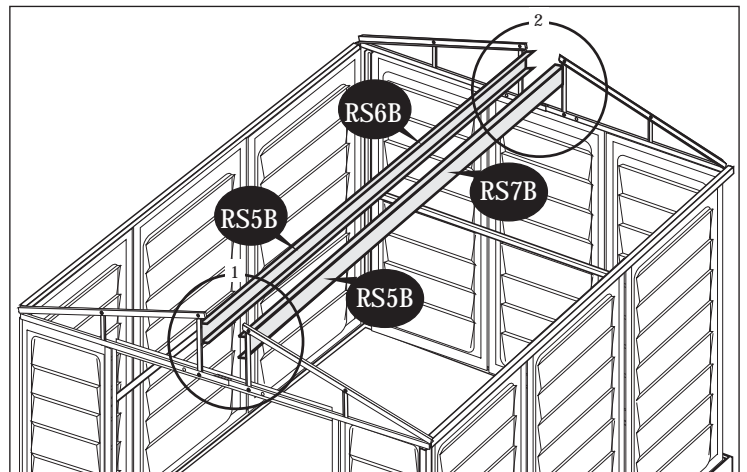

fig.1

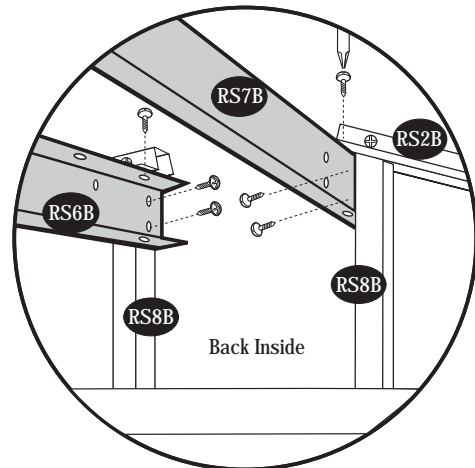
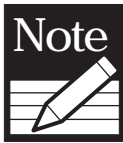
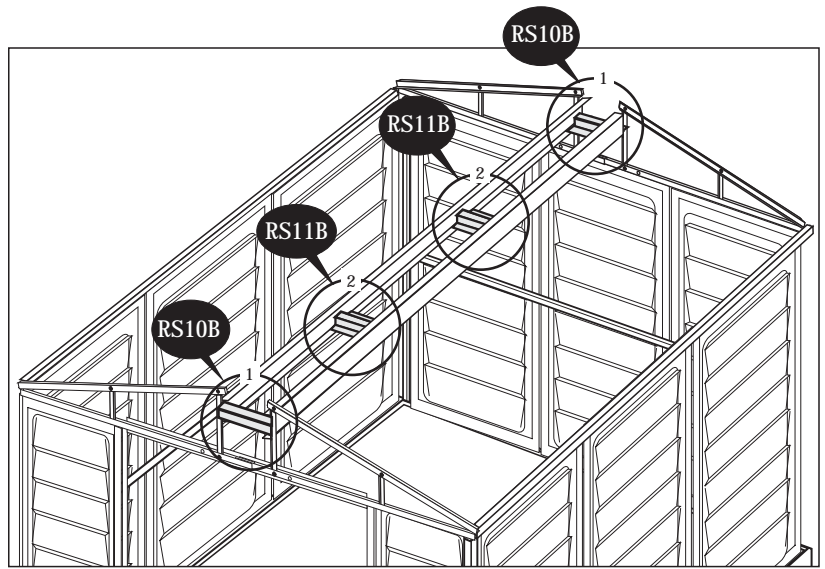
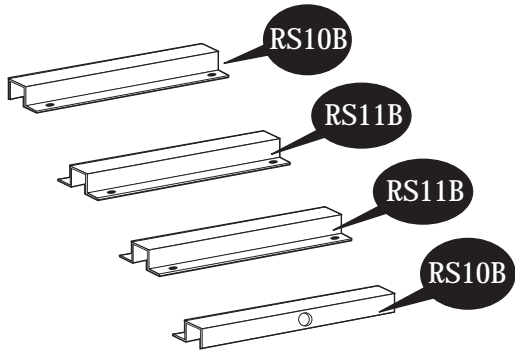

fig.2

20. Attach (RS10B) and (RS11B) to roof structures (RS5B), (RS6B) & (RS7B) using (S1) screws. See (fig.1), (fig.2) and (fig.3). Add one (RS11B) for each extension.



Note Make sure hole in (RS10B) face outward.

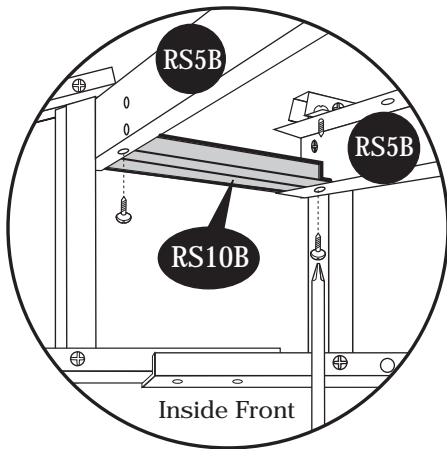
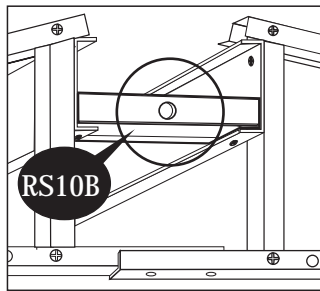

fig.1

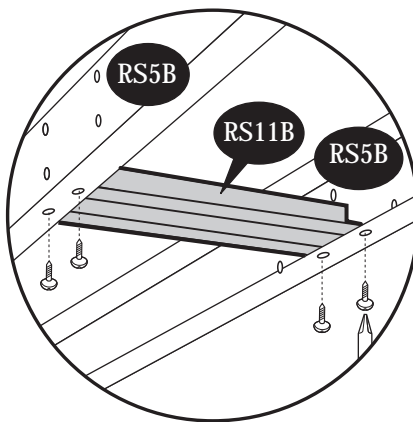

fig.2

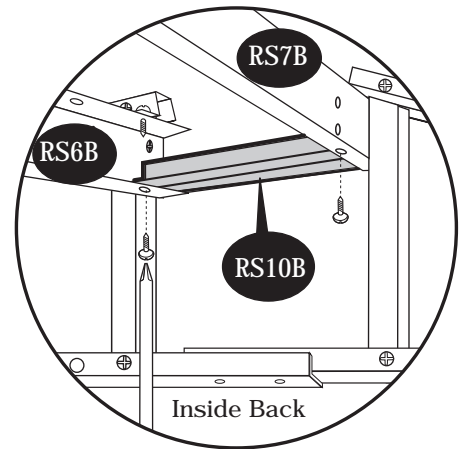

fig.3

23. Attach the roof structures (RS4B) to (RS3B) and (RS5B), (RS6B) & (RS7B) assembly with (S1) screws. See (fig.1) (fig.2) (fig.3) and (fig.4).
Add two (RS4B) for each extension.

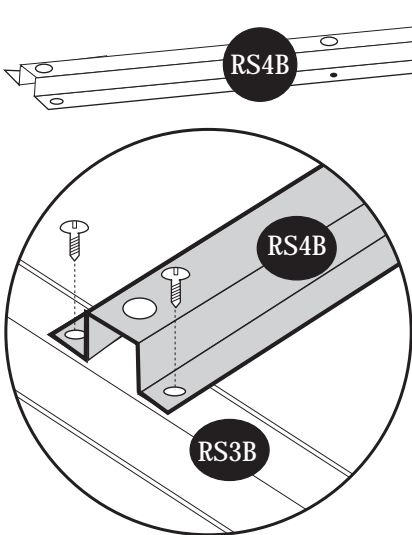
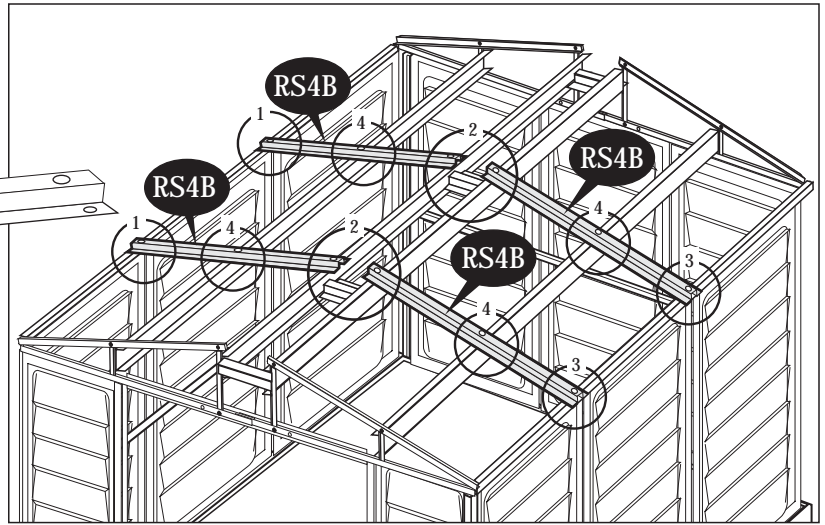

fig.1

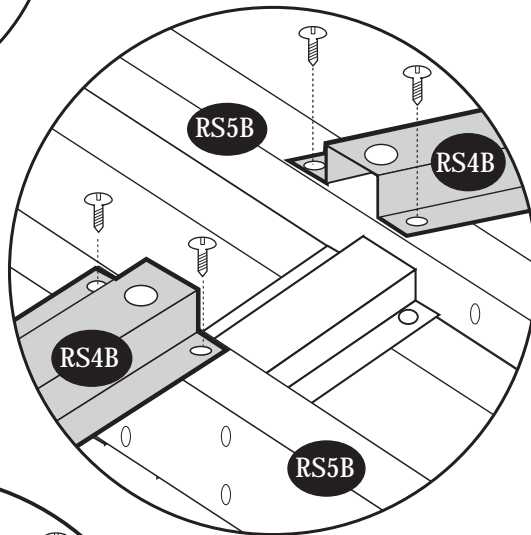

fig.2

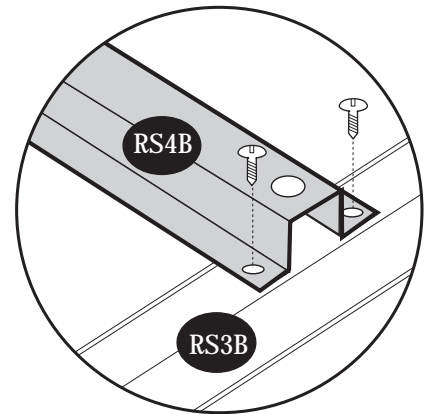

fig.3

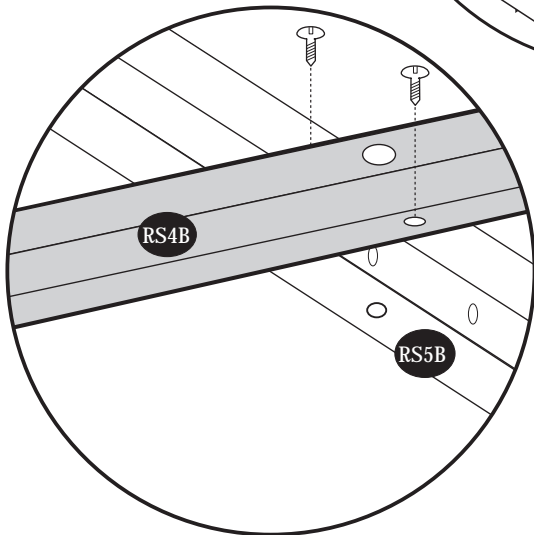
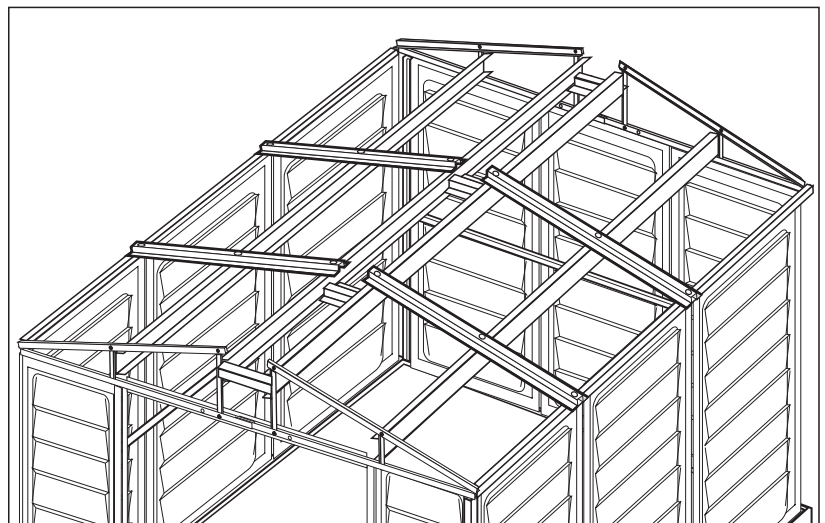

fig.4



D. Roof panels

Parts Needed:

- (4) Roof Panels (RP↑)
- (2) Facia Panel Left (FPLB)
- (2) Facia Panel Right (FPRB)
- (2) Ridge Cover (RRS)
- (64) Roof Plug Washer (PWS)
- (64) Roof Plugs (PPG)
- (64) Roof Pins (PIN)
- (8) Sagging Support (RS14B)

Parts Needed For Each Extension:

- (2) Roof Panels (RP↑)
- (1) Ridge Cover (RRS)
- (16) Roof Plug Washer (PWS)
- (16) Roof Plugs (PPG)
- (16) Roof Pins (PIN)
- (4) Sagging Support (RS14B)

1. Place facia panel (FPRB) to front roof structure right side.

2. First put the roof plug washer on the roof plug. Locate the holes in the facia panel through roof structure and fix with roof plugs w/washers. Use a hammer (rubber mallet) to drive in roof pin. See figures 1, 2 and 3 for details. Place facia panel left (FPLB) to the front roof structure left side. Make sure (FPLB) overlaps on (FPRB). Repeat action to fix facia panels on backside. See Fig. 4, 5 & 6.



TIP First insert all roof plugs with washers to the panels (left & right) then drive in the roof pins.

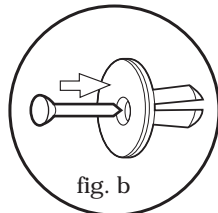
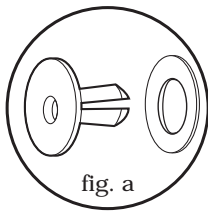

3. Start attaching the roof panels from (FPLB) corner side by sliding the roof panel (RP↑) to roof structure. Locate the hole positions of the roof panel and roof structure. Fix roof plugs with washers. Use a hammer to drive in roof pins. See figures 1 thru 6. Add two roof panels for each extension.

4. Attaching the ridge cover (RRS) on top of the roof panels (RP↑) start from the front side of the shed. See Fig.7 Fig.8 Fig.9 Add one ridge cover for each extension.

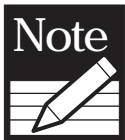

Note Use a screw driver to align the holes.

Insert roof plugs into roof panels only as indicated.

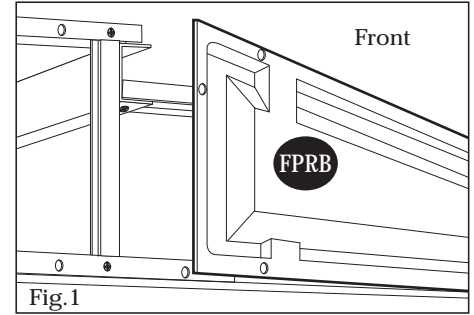

Fig.1

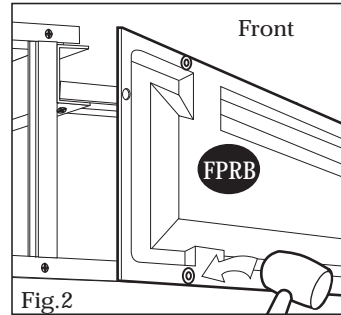

Fig.2

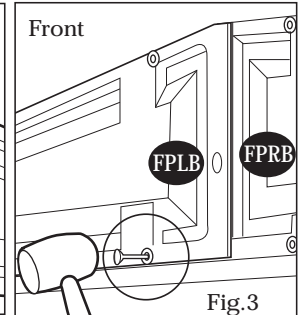

Fig.3

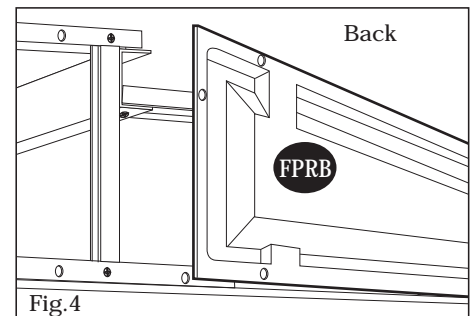

Fig.4

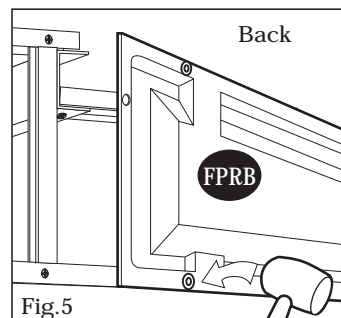

Fig.5

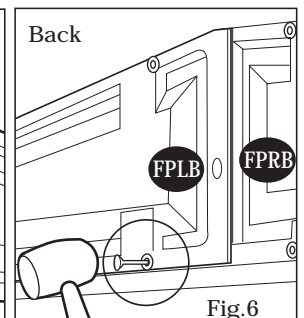

Fig.6



Note Do not insert Plugs at this point.

KEY
P Roof Plugs

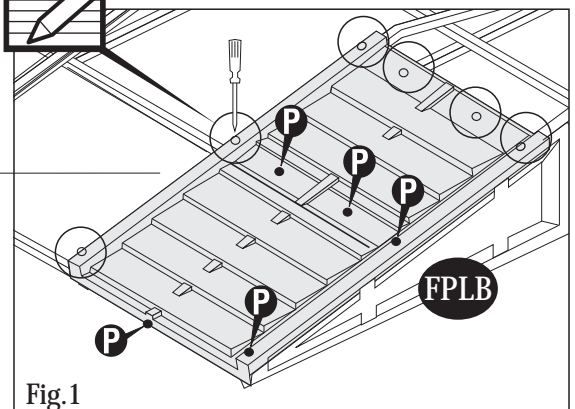
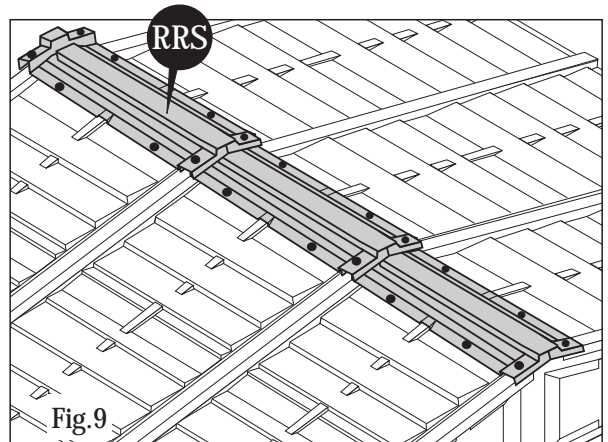
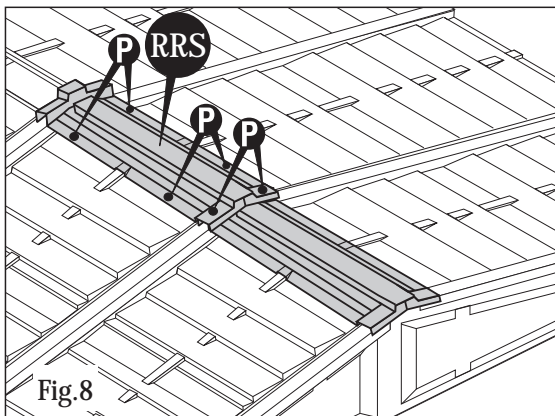
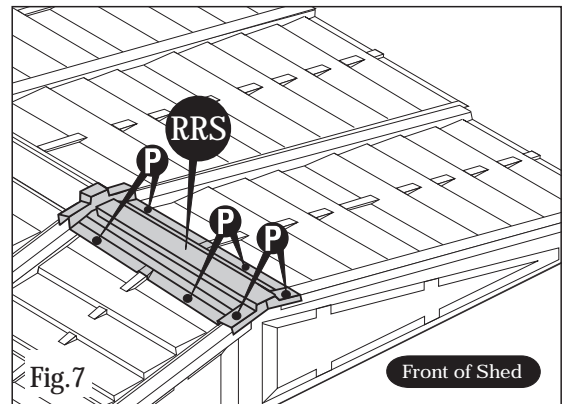
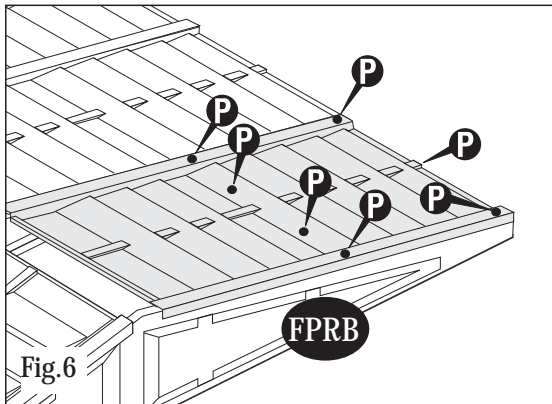
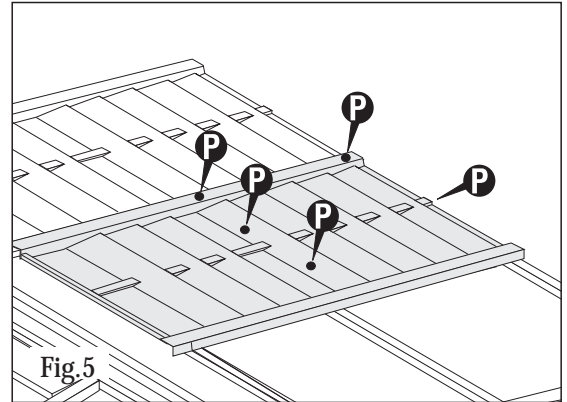
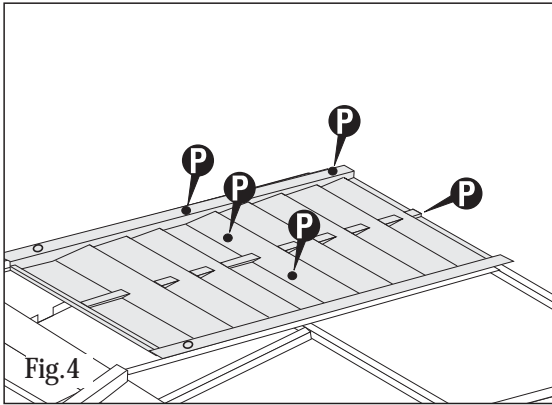
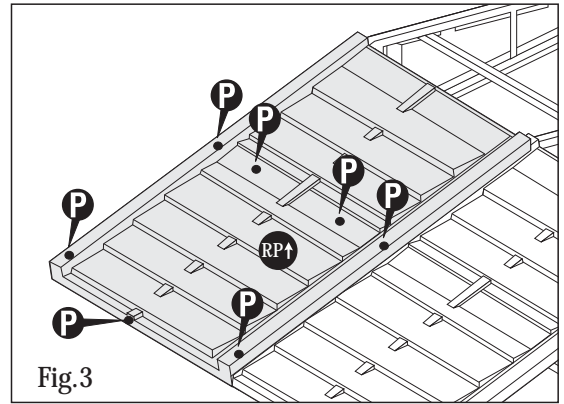
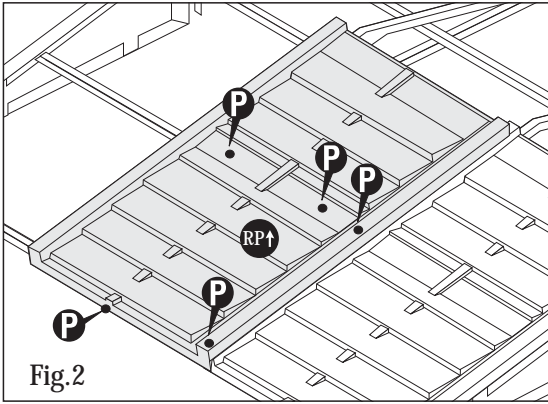
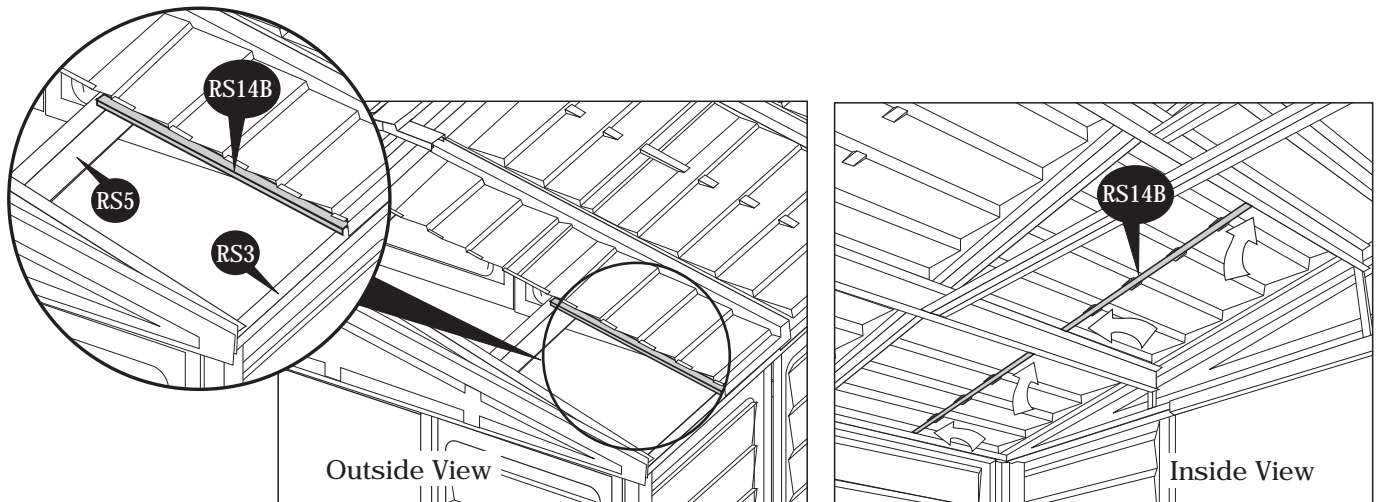

Fig.1



5. Insert the sagging support (RS14B) from inside the shed by sliding it between roof support (RS5) and roof panel until it reaches (RS3) roof support for each panel. See fig.1.

6. Insert the sagging support (RS14B) from inside the shed by sliding it between roof support (RS5) and roof panel until it touches the other roof support. See fig.2.



E. Doors

Parts Needed:

- (1) Door Left
- (1) Door Right

1. Attach the doors left and right (see fig.1) with Loose pin hinges on door columns (CDLB) and (CDRB).



Note: To prevent water leakage it is important that these instructions are followed.

1. After completing the assembly apply silicone around the perimeter of the base U-channel. Seal the corners, joints and base of door column also.

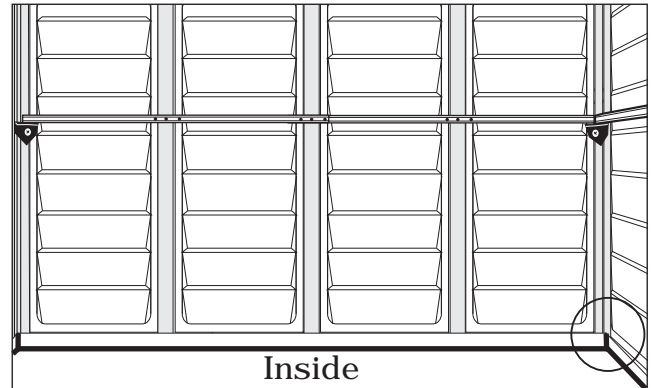
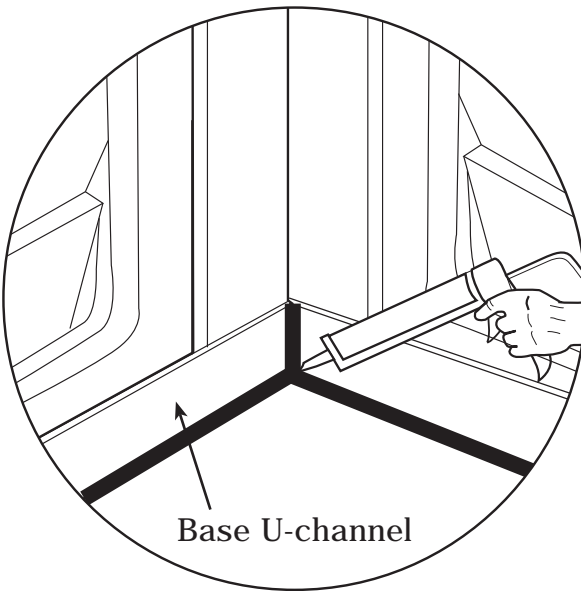

2. After completing the panel assembly, apply silicone around the roof plugs. This is optional and should be done for heavy rain areas if needed.

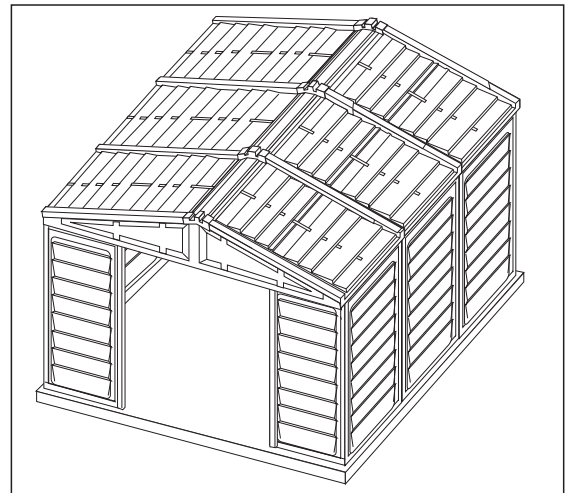
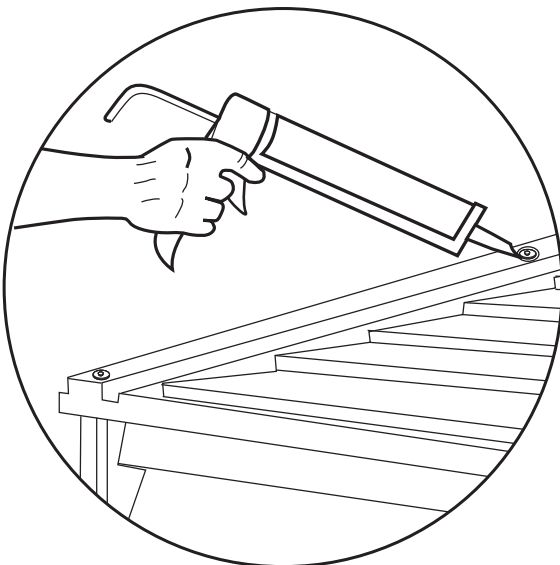

F. Optional Ventilation Kit

ACCESSORIES

CODE	DESCRIPTION	QTY
VC	VENTILATION COVER	2
VCP	VENTILATION COVER PIN	4

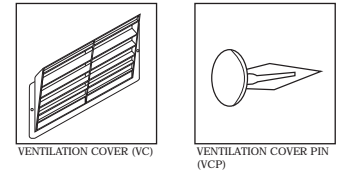

TOOLS YOU WILL NEED

Power Drill
 Dia 5/32" (4.2mm) drill bit
 Dia 1/2" (12.5mm) drill bit

Optional ventilation kits can be installed on any of the wall panels. However, we recommend mounting them on the top of the shed's back wall.

1. Place the ventilation cover (VC) as shown in fig.1. Using a pencil, mark the two side hole locations.
2. On the marked hole locations, drill out two holes using dia. 5/32" (4.2mm) drill bit as shown in fig.2. These holes will be used to attach the ventilation cover with the ventilation cover pins (VCP).
3. Use a dia. 1/2" (12.5mm) drill bit to drill out as many holes as desired behind the ventilation cover mounting area as in fig.3.
4. Attach the ventilation cover (VC) with the ventilation cover pin (VCP) as in fig.4.
5. Repeat the same to fix the second ventilation cover.

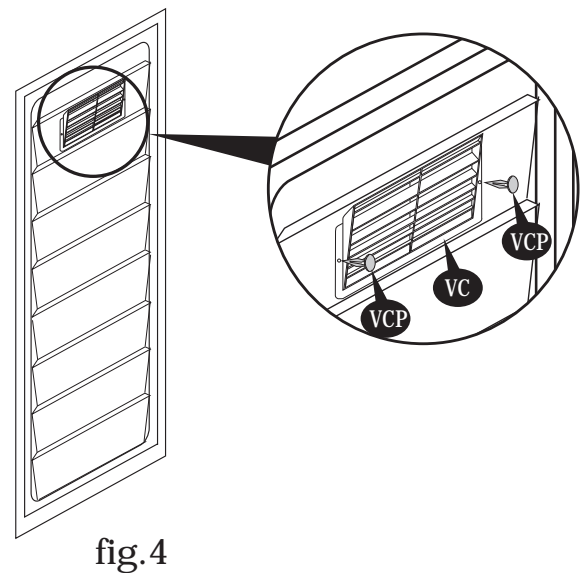
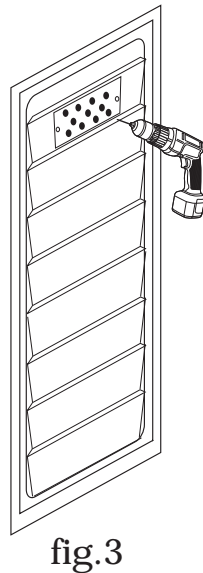
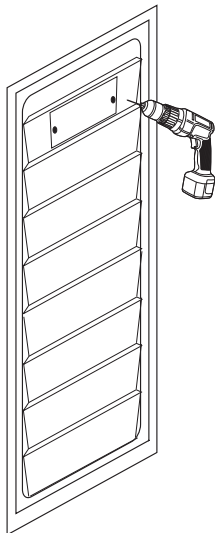
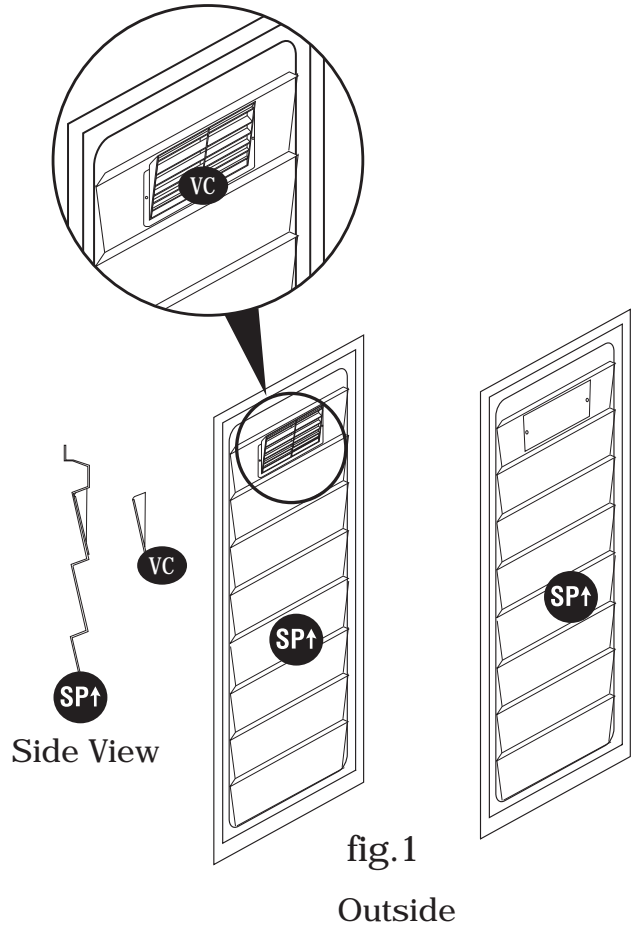

High wind area installation instructions

Note: To ensure that your shed withstands high winds, you will need the following reinforcement.

Parts needed:

CODE	DESCRIPTION	QTY
S4	DIA. 4.2 x 16mm. (5/32" x 5/8") SHEET METAL SCREW	48 (not included with shed)
S5	M6 x 40mm. (1/4" x 1 1/2") Anchor bolt with nut	24 (not included with shed)

1. Shed or shed foundation should be placed on concrete footing by use of anchor bolt and nut. Using a carpenters square, line up corners. Align U-Channel base, mark the concrete at the holes in the base and drill concrete with 1/2" (dia. 12.5mm) concrete bit to accept anchor bolts to a 1 3/4" (44mm) depth. Replace base and secure with 1/4" x 1 1/2" (M6 x 40mm) anchor bolts. See fig.

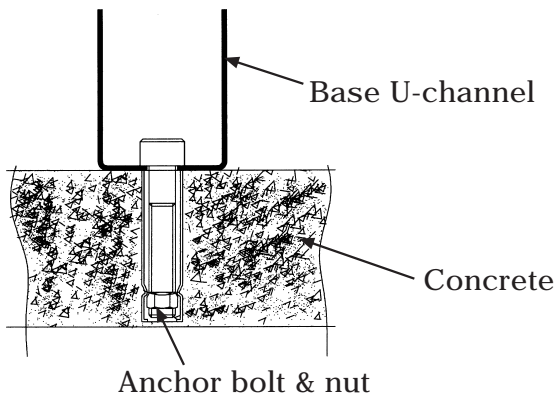
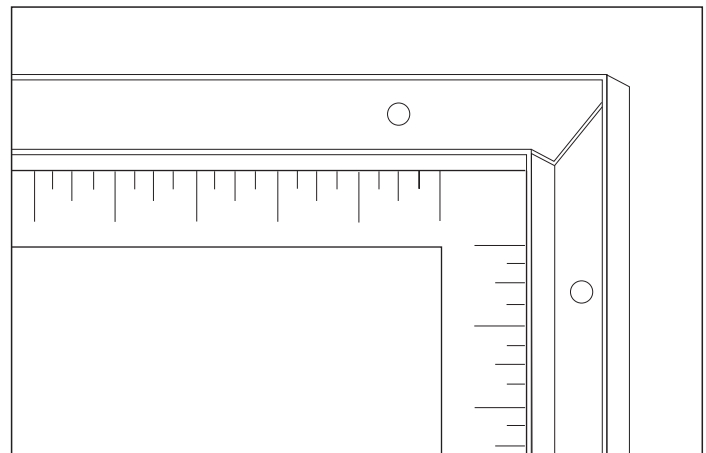

2. Attach each side panel (SP↑) on the bottom to the U-channel base. Using a dia. 3mm (1/8") drill with a power drill, make two equal distance holes on the U-channel base through the side panel. Drive a self tapping screw (S4) through the base U-channel to the side panel. Repeat this for every side panel. See blowup.

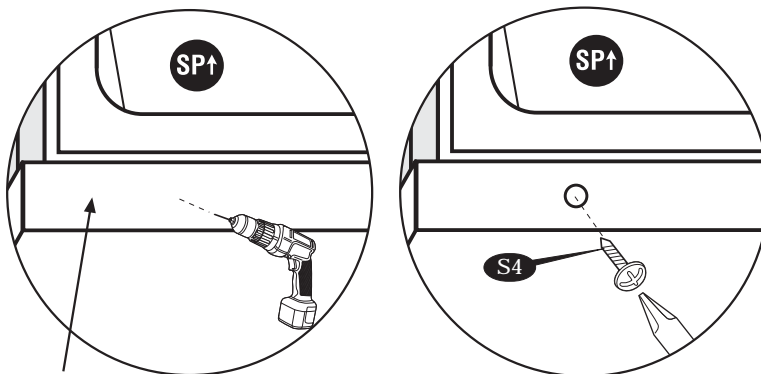
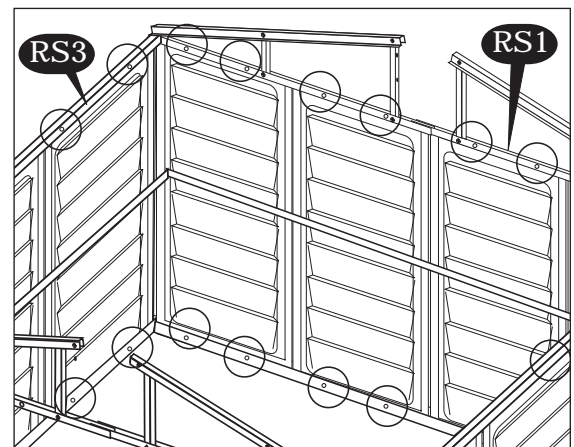

Base U-channel

3. Attach each side panel (SP↑) on top to the roof structure (RS1) and (RS3). Using a dia. 3mm (1/8") drill with a power drill, make two equal distance holes on the side panel through the roof structure. Drive a self tapping screw (S4) through the side panel to the roof structure. Repeat this for every side panel. See blowup.

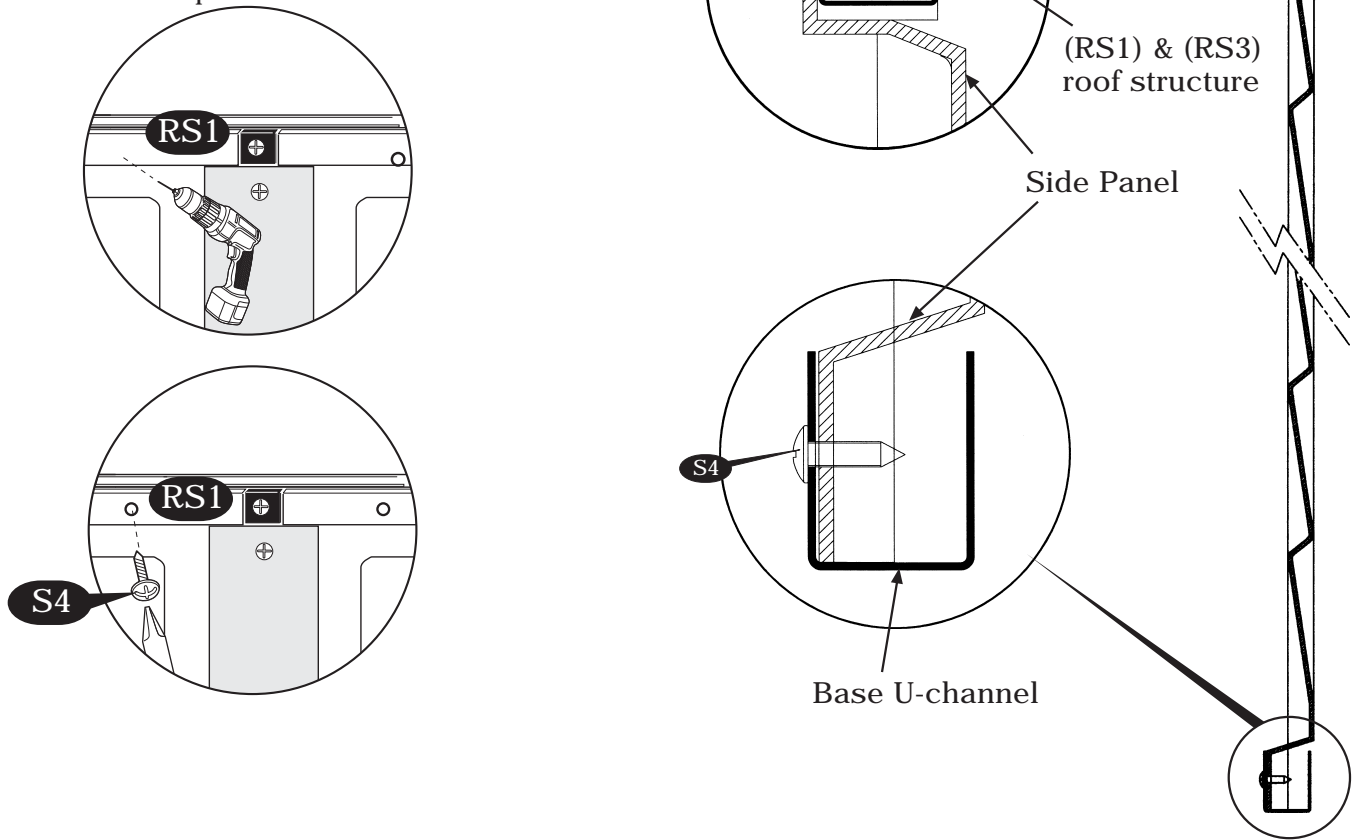

Important Warranty Information

The Duramax shed has been tested and passed wind loads of up to 115 mph in a controlled laboratory environment. Natural high wind areas create wind at unpredictable speeds that are very difficult to capture accurately by location. As such we cannot guarantee the performance of the shed in these extreme situations.

PART 2: Adding Extension Kit to Existing Shed

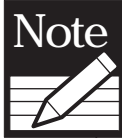
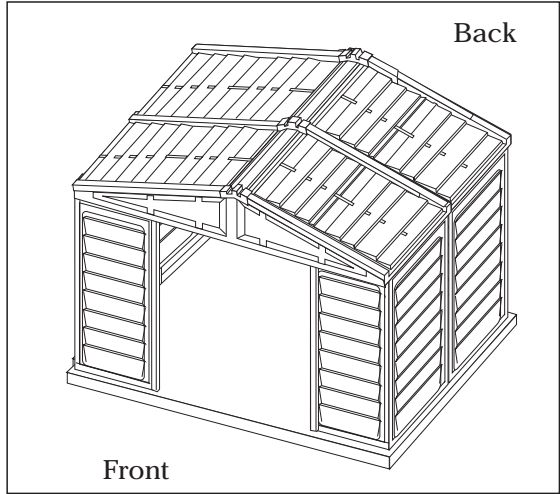

Remove this Ridge cover.

1. Remove one ridge cover (RRS) from the back side .
See the figure.



Use a drilling machine to remove the pins and plugs from the ridge cover, roof panel and fascia panel. Care should be taken not to damage the panels. Extra pins, plugs and washers are available in the accessory box.

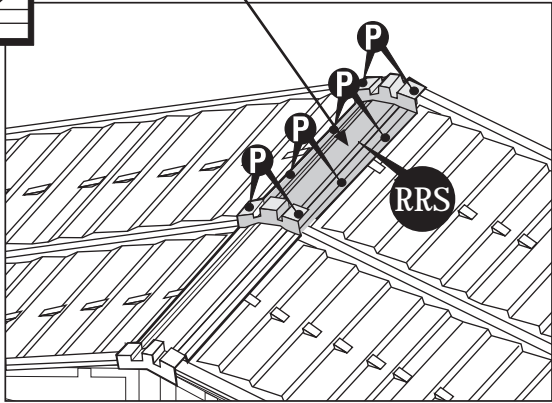

2. Remove from back side left and right roof panels.
See the figure.

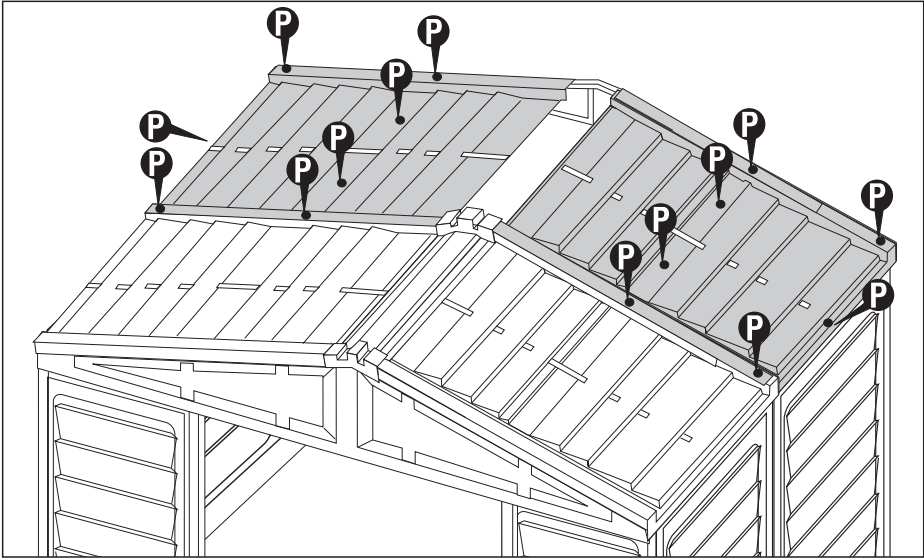

3. Remove the roof plugs and pins from backside
facia panel and detach it from the shed.

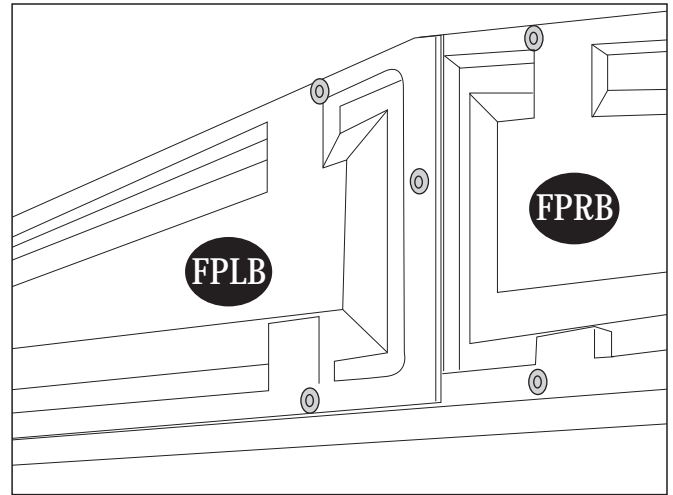

4. Support the roof structure (RS5B) & (RS5B)
by using an appropriate support to avoid the roof
structure from collapsing.

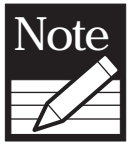

Note Support not included.

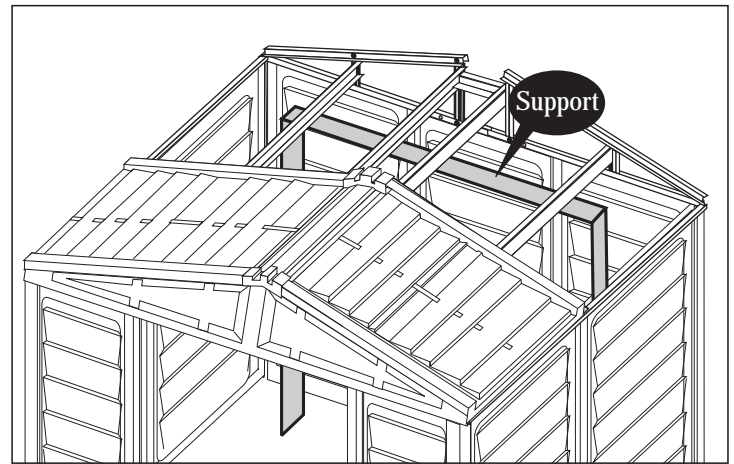

5. Remove (RS10B) from inside. See the figure.

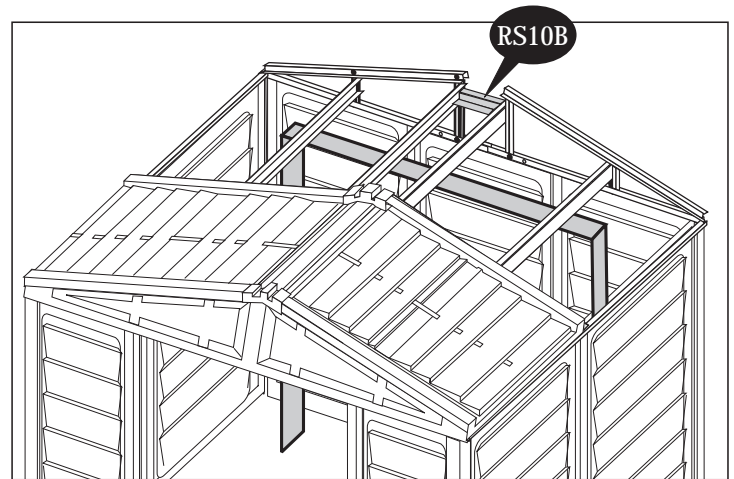
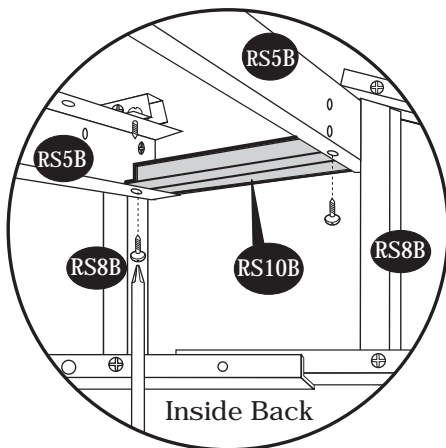

6. Detach (RS2B) from (RS5B). Then detach (RS5B) from (RS8B).

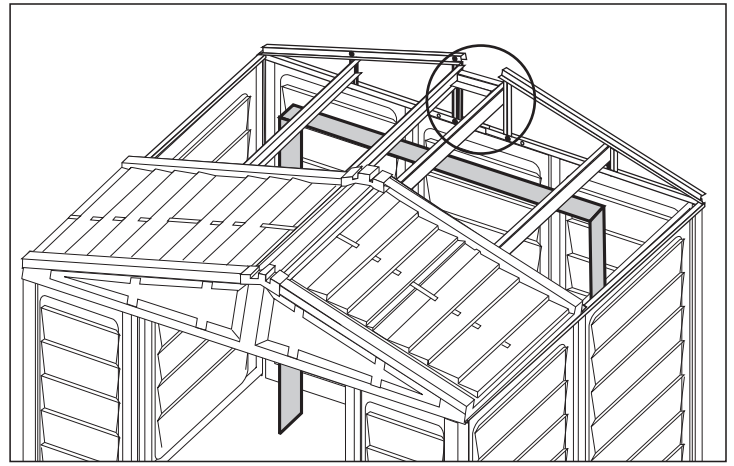
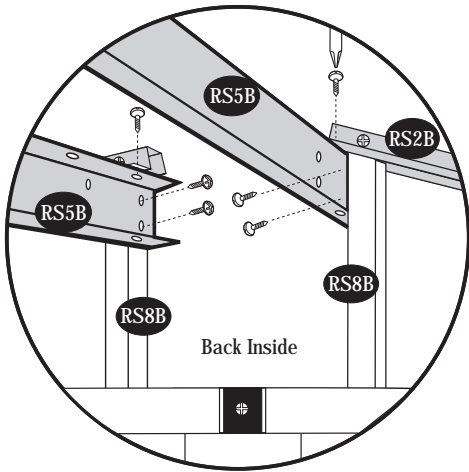

7. Detach (RS2B) from (RS5B) then (RS5B) from (RS9B) See fig.1 and fig.2.

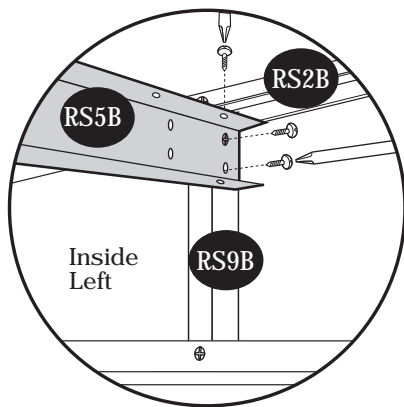
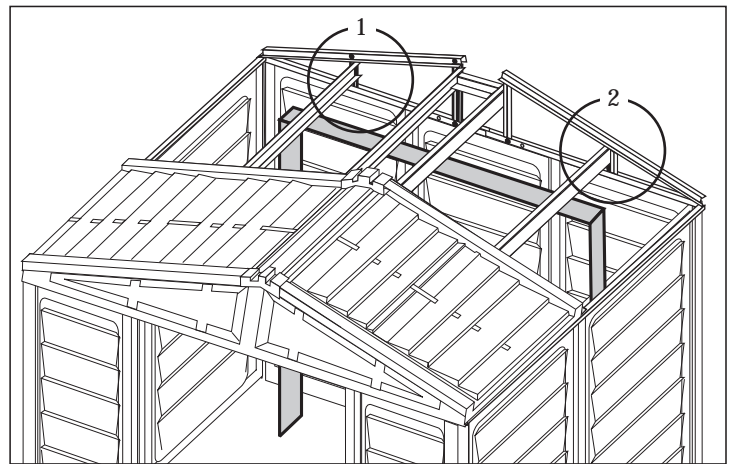

fig.1

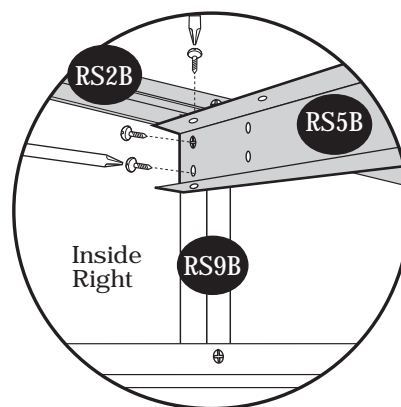

fig.2

8. Detach roof structure (RS2B) from roof structure (RS3B) from both corners. See fig.1.
 Detach 90-degree joint (RJ) from corner column fitting (FCC) from both corners. See fig.2.
 Detach (RS3B) from 90-degree joint (RJ) from both corners. See fig.3.

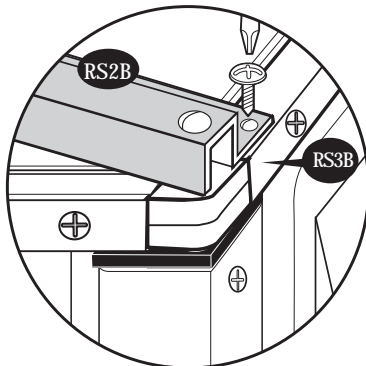
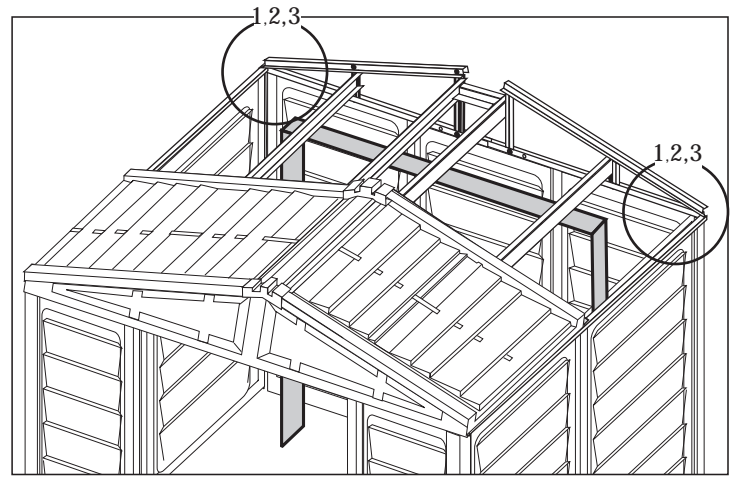

fig.1

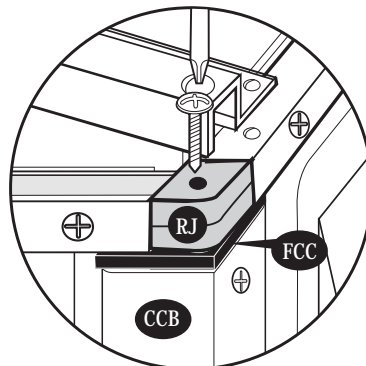

fig.2

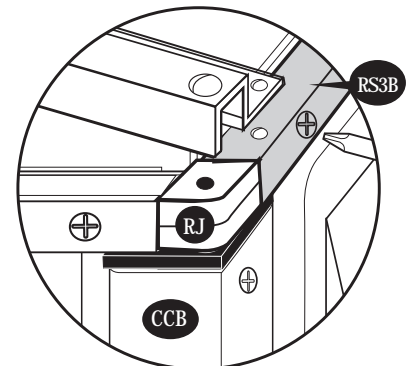
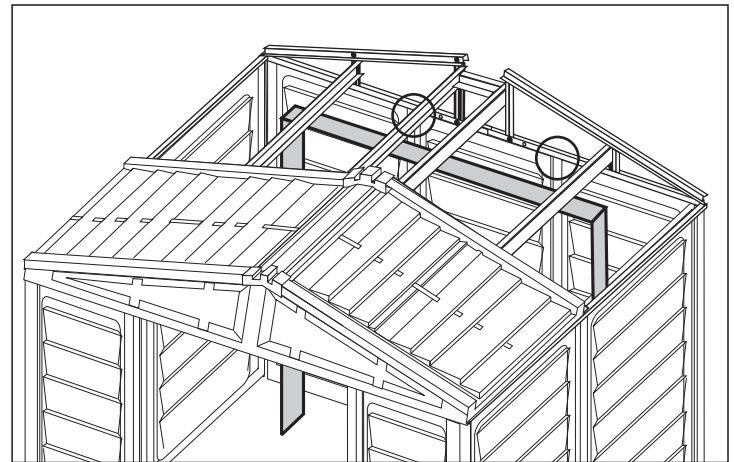
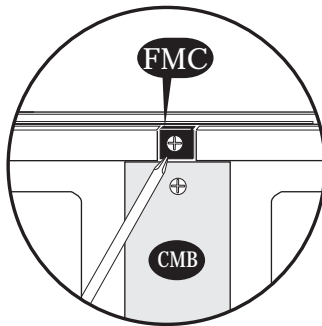
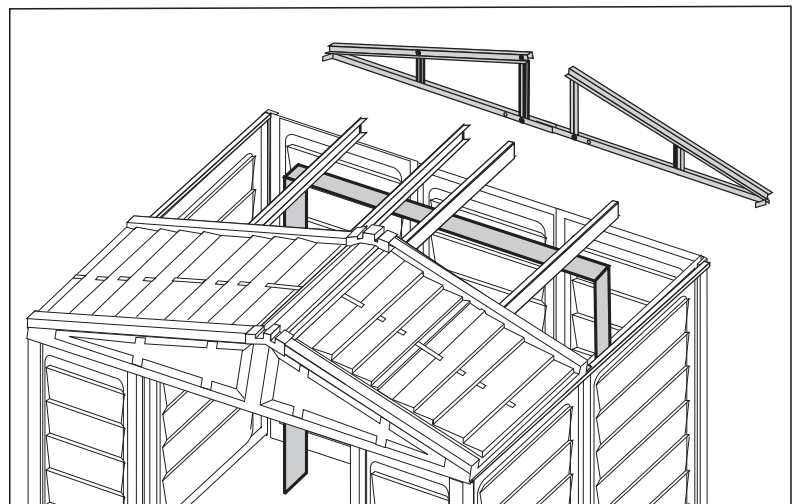

fig.3

9. Detach the middle column fittings (FMC) from back roof structure (RS1B) assembly. See figure.



10. Pull the back roof structure assembly. See figure.



11. Detach the center bands (CB3LB) & (CB3SB) assembly from the back wall of the shed. Follow the figures.

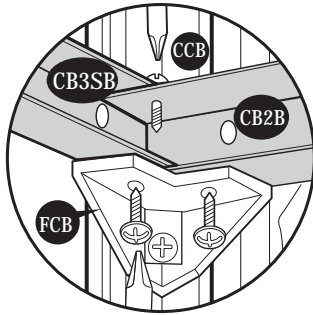

Fig. 1: Detach (CB3SB) from (CB2B). Then detach (CB3SB) & (CB2B) from (FCB).

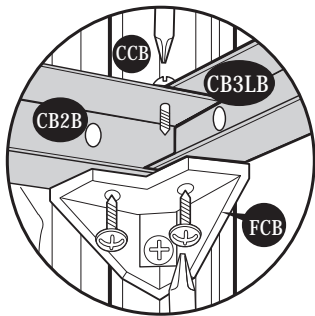
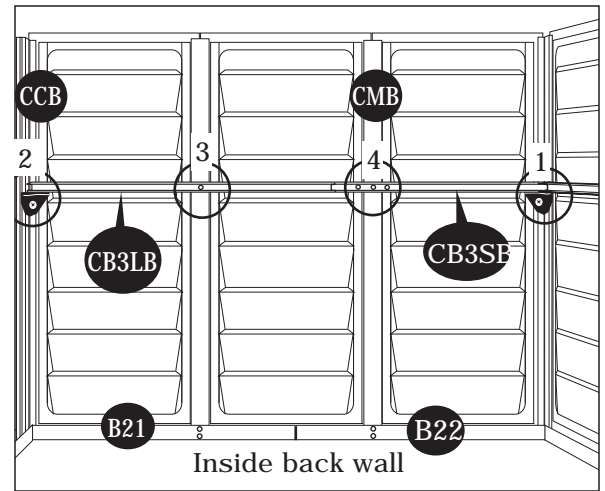

Fig. 2: Detach (CB3LB) from (CB2B). Then detach (CB3LB) & (CB2B) from (FCB).

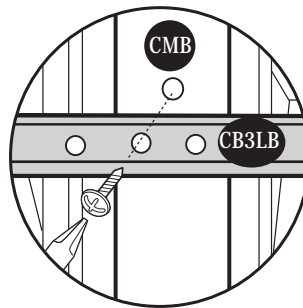

Fig. 3: Detach (CB3LB) from (CMB).

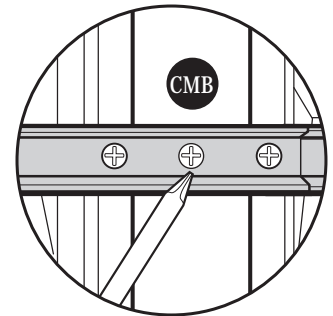

Fig. 4: Detach (CB3) assembly from (CMB).

12. From outside back of the shed detach the base angles from the corner column (CCB) at both corners and remove the corner columns. See fig. 1. From inside detach the (B21) & (B22) base angles from middle column (CMB). See fig. 2.

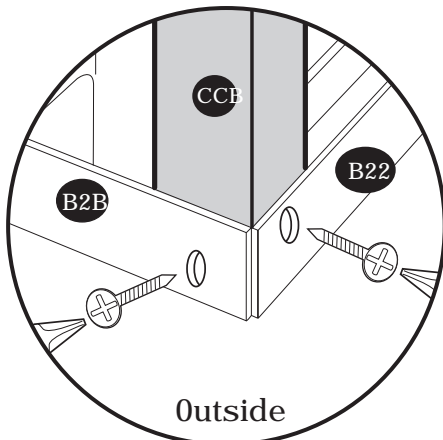

fig. 1

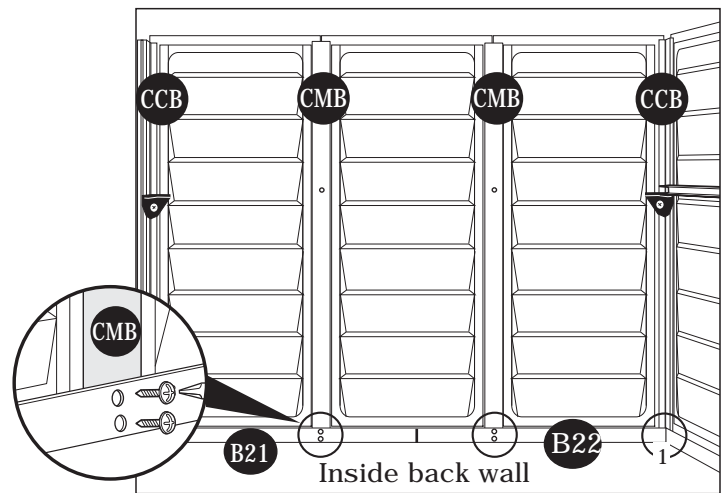

fig. 2



13. Come back to 8' x 6' Extension Kit manual (PART 1) and follow the steps accordingly.